

# SIEMENS

## MICROMASTER 430 7.5 kW - 250 kW

Operating Instructions

Issue 12/02



# MICROMASTER 430 Documentation

## Getting Started Guide

Is for quick commissioning with SDP and BOP-2.

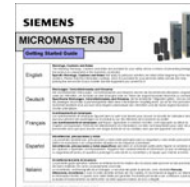

## Operating Instructions

Gives information about features of the MICROMASTER 430, Installation, Commissioning, Control modes, System Parameter structure, Troubleshooting, Specifications and available options of the MICROMASTER 430.



## Parameter List

The Parameter List contains the description of all Parameters structured in functional order and a detailed description. The Parameter list also includes a series of function plans.



## Catalogues

In the catalogue you will find all the necessary information to select an appropriate inverter, as well as filters, chokes, operator panels and communication options.

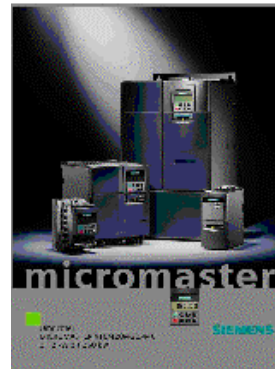



# MICROMASTER 430

7.5 kW - 250 kW

**Operating Instructions**  
User Documentation

**Valid for**

Issue 12/02

*Converter Type*  
MICROMASTER 430

*Software Version*  
V2.0

**Issue 12/02**

|   |  |
|---|--|
| <b>Overview</b>                           | <b>1</b>                               |
| <b>Installation</b>                       | <b>2</b>                               |
| <b>Commissioning</b>                      | <b>3</b>                               |
| <b>MICROMASTER 430<br/>Functions</b>      | <b>4</b>                               |
| <b>System Parameters</b>                  | <b>5</b>                               |
| <b>Troubleshooting</b>                    | <b>6</b>                               |
| <b>Specifications</b>                     | <b>7</b>                               |
| <b>Available options</b>                  | <b>8</b>                               |
| <b>Electro-Magnetic<br/>Compatibility</b> | <b>9</b>                               |
| <b>Appendices</b>                         | <b>A<br/>B<br/>C<br/>D<br/>E<br/>F</b> |
| <b>Index</b>                              |  |

## IMPORTANT NOTICE

Not all inverters currently have UL approval.

UL listing can be determined by examining the inverter's Rating Label.

For UL listed products the following UL mark is used:



Note: UL certification is presently in progress!

Further information can be obtained from Internet website:

<http://www.siemens.de/micromaster>

Approved Siemens Quality for Software and Training is to DIN ISO 9001, Reg. No. 2160-01

The reproduction, transmission or use of this document, or its contents is not permitted unless authorized in writing. Offenders will be liable for damages. All rights including rights created by patent grant or registration of a utility model or design are reserved.

© Siemens AG 2002. All Rights Reserved.

MICROMASTER® is a registered trademark of Siemens

Other functions not described in this document may be available. However, this fact shall not constitute an obligation to supply such functions with a new control, or when servicing.

We have checked that the contents of this document correspond to the hardware and software described. There may be discrepancies nevertheless, and no guarantee can be given that they are completely identical. The information contained in this document is reviewed regularly and any necessary changes will be included in the next edition. We welcome suggestions for improvement.

Siemens handbooks are printed on chlorine-free paper that has been produced from managed sustainable forests. No solvents have been used in the printing or binding process.

Document subject to change without prior notice.

---

Order number: 6SE6400-5AE00-0BP0

Siemens-Aktiengesellschaft

# Foreword

## User Documentation

---



### **WARNING**

Before installing and commissioning the inverter, you must read all safety instructions and warnings carefully including all the warning labels attached to the equipment. Make sure that the warning labels are kept in a legible condition and replace missing or damaged labels.

---

Information is also available from:

### **Technical Support Nuremberg**

Tel: +49 (0) 180 5050 222

Fax: +49 (0) 180 5050 223

Email: [techsupport@ad.siemens.de](mailto:techsupport@ad.siemens.de)

Monday to Friday: 7:00 am to 5:00 pm (local time)

### **Internet Home Address**

Customers can access technical and general information at:

<http://www.siemens.de/micromaster>

### **Contact address**

Should any questions or problems arise while reading this manual, please contact the Siemens office concerned using the form provided at the back this manual.

## Definitions and Warnings



### **DANGER**

indicates an imminently hazardous situation which, if not avoided, will result in death or serious injury.



### **WARNING**

indicates a potentially hazardous situation which, if not avoided, could result in death or serious injury.



### **CAUTION**

used with the safety alert symbol indicates a potentially hazardous situation which, if not avoided, may result in minor or moderate injury.

### **CAUTION**

used without safety alert symbol indicates a potentially hazardous situation which, if not avoided, may result in a property damage.

### **NOTICE**

indicates a potential situation which, if not avoided, may result in an undesirable result or state.

### **NOTE**

For the purpose of this documentation, "Note" indicates important information relating to the product or highlights part of the documentation for special attention.

### **Qualified personnel**

For the purpose of this Instruction Manual and product labels, a "Qualified person" is someone who is familiar with the installation, mounting, start-up and operation of the equipment and the hazards involved.

He or she must have the following qualifications:

1. Trained and authorized to energize, de-energize, clear, ground and tag circuits and equipment in accordance with established safety procedures.
2. Trained in the proper care and use of protective equipment in accordance with established safety procedures.
3. Trained in rendering first aid.

PE  
 = Ground

➤ PE – Protective Earth uses circuit protective conductors sized for short circuits where the voltage will not rise in excess of 50 Volts. This connection is normally used to ground the inverter.

➤  - Is the ground connection where the reference voltage can be the same as the Earth voltage. This connection is normally used to ground the motor.

### **Use for intended purpose only**

The equipment may be used only for the application stated in the manual and only in conjunction with devices and components recommended and authorized by Siemens.

# Safety Instructions

The following Warnings, Cautions and Notes are provided for your safety and as a means of preventing damage to the product or components in the machines connected. This section lists Warnings, Cautions and Notes, which apply generally when handling MICROMASTER 430 Inverters, classified as **General, Transport & Storage, Commissioning, Operation, Repair and Dismantling & Disposal**.

**Specific Warnings, Cautions and Notes** that apply to particular activities are listed at the beginning of the relevant chapters and are repeated or supplemented at critical points throughout these sections.

**Please read the information carefully, since it is provided for your personal safety and will also help prolong the service life of your MICROMASTER 430 Inverter and the equipment you connect to it.**

## General



### WARNING

- This equipment contains dangerous voltages and controls potentially dangerous rotating mechanical parts. Non-compliance with **Warnings** or failure to follow the instructions contained in this manual can result in loss of life, severe personal injury or serious damage to property.
- Only suitable qualified personnel should work on this equipment, and only after becoming familiar with all safety notices, installation, operation and maintenance procedures contained in this manual. The successful and safe operation of this equipment is dependent upon its proper handling, installation, operation and maintenance.
- Risk of electric shock. The DC link capacitors remain charged for five minutes after power has been removed. **It is not permissible to open the equipment until 5 minutes after the power has been removed.**
- HP ratings are based on the Siemens 1LA motors and are given for guidance only; they do not necessarily comply with UL or NEMA HP ratings.



### CAUTION

- Children and the general public must be prevented from accessing or approaching the equipment!
- This equipment may only be used for the purpose specified by the manufacturer. Unauthorized modifications and the use of spare parts and accessories that are not sold or recommended by the manufacturer of the equipment can cause fires, electric shocks and injuries.

### NOTICE

- Keep these operating instructions within easy reach of the equipment and make them available to all users
- Whenever measuring or testing has to be performed on live equipment, the regulations of Safety Code VBG 4.0 must be observed, in particular §8 "Permissible Deviations when Working on Live Parts". Suitable electronic tools should be used.
- Before installing and commissioning, please read these safety instructions and warnings carefully and all the warning labels attached to the equipment. Make sure that the warning labels are kept in a legible condition and replace missing or damaged labels.

## Transport & Storage



### WARNING

- Correct transport, storage, erection and mounting, as well as careful operation and maintenance are essential for proper and safe operation of the equipment.

### CAUTION

- Protect the inverter against physical shocks and vibration during transport and storage. Also be sure to protect it against water (rainfall) and excessive temperatures (see table on page 104).

## Commissioning



### WARNING

- Work on the device/system by **unqualified** personnel or failure to comply with warnings can result in severe personal injury or serious damage to material. Only suitably qualified personnel trained in the setup, installation, commissioning and operation of the product should carry out work on the device/system.
- Only permanently-wired input power connections are allowed. This equipment must be grounded (IEC 536 Class 1, NEC and other applicable standards).
- If a Residual Current-operated protective Device (RCD) is to be used, it must be an RCD type B. Machines with a three-phase power supply, fitted with EMC filters, must not be connected to a supply via an ELCB (Earth Leakage Circuit-Breaker - see *DIN VDE 0160, section 5.5.2 and EN 50178 section 5.2.11.1*).
- The following terminals can carry dangerous voltages even if the inverter is inoperative:
  - the power supply L/L1, N/L2, L3 resp. U1/L1, V1/L2, W1/L3
  - the motor terminals U, V, W resp. U2/T1, V2/T2, W2/T3
  - and depending on the frame size the terminals DC+/B+, DC-, B-, DC/R+ resp. C/L+, D/L-
- This equipment must not be used as an 'emergency stop mechanism' (see *EN 60204, 9.2.5.4*)



### CAUTION

The connection of power, motor and control cables to the inverter must be carried out as shown in Figure 2-13 on page 39, to prevent inductive and capacitive interference from affecting the correct functioning of the inverter.



## Operation



### WARNING

- MICROMASTERS operate at high voltages.
- When operating electrical devices, it is impossible to avoid applying hazardous voltages to certain parts of the equipment.
- Emergency Stop facilities according to EN 60204 IEC 204 (VDE 0113) must remain operative in all operating modes of the control equipment. Any disengagement of the Emergency Stop facility must not lead to uncontrolled or undefined restart.
- Wherever faults occurring in the control equipment can lead to substantial material damage or even grievous bodily injury (i.e. potentially dangerous faults), additional external precautions must be taken or facilities provided to ensure or enforce safe operation, even when a fault occurs (e.g. independent limit switches, mechanical interlocks, etc.).
- Certain parameter settings may cause the inverter to restart automatically after an input power failure.
- Motor parameters must be accurately configured for motor overload protection to operate correctly.
- This equipment is capable of providing internal motor overload protection in accordance with UL508C section 42. Refer to P0610 and P0335, i<sup>2</sup>t is ON by default. Motor overload protection can also be provided using an external PTC (disabled by default P0601).
- This equipment is suitable for use in a circuit capable of delivering not more than 10,000 symmetrical amperes (rms), for a maximum voltage of 460V when protected by a H or K type fuse (see *Tables starting on page 105*).
- This equipment must not be used as an 'emergency stop mechanism' (see *EN 60204, 9.2.5.4*)

## Repair



### WARNING

- Repairs on equipment may only be carried out by **Siemens Service**, by repair centers **authorized by Siemens** or by **authorized** personnel who are thoroughly acquainted with all the warnings and operating procedures contained in this manual.
- Any defective parts or components must be replaced using parts contained in the relevant spare parts list.
- Disconnect the power supply across all poles before opening the equipment for access.

## Dismantling & Disposal

### CAUTION

- The inverter's packaging is re-usable. Retain the packaging for future use or return it to the manufacturer.
- Easy-to-release screw and snap connectors allow you to break the unit down into its component parts. You can then recycle these component parts, dispose of them in **accordance with local requirements or return them to the manufacturer.**



# Table of Contents

|          |   |            |
|----------|---|------------|
| <b>1</b> | <b>Overview .....</b>                               | <b>15</b>  |
| 1.1      | The MICROMASTER 430.....                            | 16         |
| 1.2      | Features.....                                       | 17         |
| <b>2</b> | <b>Installation .....</b>                           | <b>19</b>  |
| 2.1      | Installation after a Period of Storage .....        | 21         |
| 2.2      | Ambient operating conditions .....                  | 22         |
| 2.3      | Mechanical installation.....                        | 24         |
| 2.4      | Electrical installation .....                       | 30         |
| <b>3</b> | <b>Commissioning .....</b>                          | <b>41</b>  |
| 3.1      | Block diagram .....                                 | 43         |
| 3.2      | Commission modes .....                              | 45         |
| 3.3      | General operation .....                             | 56         |
| <b>4</b> | <b>MICROMASTER 430 functions .....</b>              | <b>58</b>  |
| 4.1      | Frequency set point (P1000) .....                   | 59         |
| 4.2      | Command sources (P0700).....                        | 60         |
| 4.3      | OFF and brake function .....                        | 60         |
| 4.4      | Control modes (P1300).....                          | 62         |
| 4.5      | MICROMASTER 430 operating modes .....               | 63         |
| 4.6      | Free Function Blocks (P2800 ff) .....               | 67         |
| 4.7      | Faults and Alarms .....                             | 67         |
| <b>5</b> | <b>System parameters.....</b>                       | <b>69</b>  |
| 5.1      | Introduction to MICROMASTER system parameters ..... | 70         |
| 5.2      | Parameter overview .....                            | 71         |
| 5.3      | Parameter list (short form) .....                   | 72         |
| 5.4      | Command and Drive Datasets - Overview .....         | 85         |
| <b>6</b> | <b>Troubleshooting.....</b>                         | <b>89</b>  |
| 6.1      | Troubleshooting with the SDP .....                  | 90         |
| 6.2      | Troubleshooting with the BOP-2.....                 | 91         |
| 6.3      | Fault messages.....                                 | 92         |
| 6.4      | Alarm Messages .....                                | 98         |
| <b>7</b> | <b>MICROMASTER 430 specifications.....</b>          | <b>103</b> |
| <b>8</b> | <b>Options .....</b>                                | <b>111</b> |
| 8.1      | Device-independent options .....                    | 111        |

|                         |   |            |
|-------------------------|---|------------|
| 8.2                     | Device-dependent options .....                    | 111        |
| <b>9</b>                | <b>Electro-magnetic compatibility (EMC) .....</b> | <b>113</b> |
| 9.1                     | Electro-magnetic compatibility .....              | 114        |
| <b>Appendices .....</b> |   | <b>119</b> |
| <b>A</b>                | <b>Changing the Operator Panel .....</b>          | <b>119</b> |
| <b>B</b>                | <b>Removing Front Covers .....</b>                | <b>120</b> |
| B.1                     | Removing Front Covers Frame Size C.....           | 120        |
| B.2                     | Removing Front Covers Frame Sizes D and E .....   | 121        |
| B.3                     | Removing Covers Frame Size F.....                 | 122        |
| B.4                     | Removing Front Covers Frame Sizes FX and GX.....  | 123        |
| <b>C</b>                | <b>Removing the I/O Board.....</b>                | <b>124</b> |
| <b>D</b>                | <b>Removing 'Y' Cap .....</b>                     | <b>125</b> |
| D.1                     | Removing 'Y' Cap Frame Size C .....               | 125        |
| D.2                     | Removing 'Y' Cap Frame Sizes D and E.....         | 126        |
| D.3                     | Removing 'Y' Cap Frame Sizes F.....               | 127        |
| D.4                     | Removing 'Y' Cap Frame Sizes FX .....             | 128        |
| D.5                     | Removing 'Y' Cap Frame Sizes GX.....              | 129        |
| <b>E</b>                | <b>Applicable Standards .....</b>                 | <b>130</b> |
| <b>F</b>                | <b>List of Abbreviations .....</b>                | <b>131</b> |
| <b>Index .....</b>      |   | <b>135</b> |

## List of Illustrations

|             |   |                                     |
|-------------|---|-------------------------------------|
| Figure 2-1  | Forming .....   | <b>Error! Bookmark not defined.</b> |
| Figure 2-2  | Ambient operating temperature .....   | 22                                  |
| Figure 2-3  | Installation altitude.....  | 22                                  |
| Figure 2-4  | Drill pattern for MICROMASTER 430 Frame Sizes C to F .....  | 25                                  |
| Figure 2-5  | Installation dimensions for MICROMASTER 430 Frame size FX .....                                   | 26                                  |
| Figure 2-6  | Installation dimensions for MICROMASTER 430 Frame sizeGX .....                                    | 27                                  |
| Figure 2-7  | Options for the electronic box.....   | 29                                  |
| Figure 2-8  | MICROMASTER 430 Connection Terminals, Frame Sizes C to F .....                                    | 33                                  |
| Figure 2-9  | MICROMASTER 430 connection drawing – frame size FX.....   | 34                                  |
| Figure 2-10 | MICROMASTER 430 connection drawing – frame size GX .....  | 35                                  |
| Figure 2-11 | Motor and Power Connections .....   | 36                                  |
| Figure 2-12 | Adaptation of fan voltage.....  | 37                                  |
| Figure 2-13 | Wiring Guidelines to Minimize the Effects of EMI .....  | 39                                  |
| Figure 3-1  | Inverter block diagram .....  | 43                                  |
| Figure 3-2  | Configuration of the analogue input as a digital input .....                                      | 44                                  |
| Figure 3-3  | Panels available for the MICROMASTER 430 Inverter .....   | 45                                  |
| Figure 3-4  | DIP switch .....  | 45                                  |
| Figure 3-5  | Basic operation with SDP .....  | 47                                  |
| Figure 3-6  | Buttons on the BOP-2.....   | 50                                  |
| Figure 3-7  | Changing parameters via the BOP-2.....  | 51                                  |
| Figure 3-8  | Typical Motor Rating Plate Example (The details given on the rating plate are only examples)..... | 55                                  |
| Figure 3-9  | Thermal overload protection.....  | 57                                  |
| Figure 4-1  | Bypass circuit .....  | 63                                  |
| Figure 4-2  | Belt Failure Detection .....  | 64                                  |
| Figure 4-3  | Motor Staging .....   | 65                                  |
| Figure 4-4  | Energy Saving Mode .....  | 66                                  |
| Figure 5-1  | Parameter Overview.....   | 71                                  |

**List of Tables**

|           |   |     |
|-----------|---|-----|
| Table 2-1 | Dimensions and Torques of MICROMASTER 430.....  | 28  |
| Table 3-1 | Default settings for operation using the SDP.....   | 46  |
| Table 3-2 | Default settings for operation using the BOP-2.....   | 49  |
| Table 6-1 | Inverter conditions indicated by the LEDs on the SDP.....                                   | 90  |
| Table 7-1 | MICROMASTER 430 Performance Ratings.....  | 104 |
| Table 7-2 | Tightening torques for power terminals.....   | 105 |
| Table 7-3 | Current reduction depending on pulse frequency.....   | 105 |
| Table 7-4 | MICROMASTER 430 Specifications.....   | 106 |
| Table 9-1 | General Industrial (unfiltered inverters together with approved external mains filter)..... | 115 |
| Table 9-2 | Filtered Industrial.....  | 116 |
| Table 9-3 | Filtered for Residential, Commercial and Light Industry.....                                | 117 |
| Table 9-4 | Compliance Table.....   | 118 |

# 1 Overview

**This Chapter contains:**

A summary of the major features of the MICROMASTER 430 range.

|     |                          |    |
|-----|--------------------------|----|
| 1.1 | The MICROMASTER 430..... | 16 |
| 1.2 | Features.....            | 17 |

## 1.1 The MICROMASTER 430

The MICROMASTER 430s are a range of 3AC-frequency inverters for controlling the speed of three phase AC motors. The various models available range from the 7,5 kW input to the 250 kW input.

The MICROMASTER 430 is especially well suited for use with pumps and ventilators when used with its factory set functions and settings.

The inverters are microprocessor-controlled and use state-of-the-art Insulated Gate Bipolar Transistor (IGBT) technology. This makes them reliable and versatile. A special pulse-width modulation method with selectable Pulse frequency permits quiet motor operation. Comprehensive protective functions provide excellent inverter and motor protection.



## 1.2 Features

### Main Characteristics

- Easy installation
- Easy commissioning
- Rugged EMC design
- Can be operated on IT line supplies
- Fast repeatable response time to control signals
- Comprehensive range of parameters enabling configuration for a wide range of applications
- Simple cable connection
- Output relays
- Analog outputs (0 – 20 mA)
- 6 Isolated and switchable NPN/PNP digital inputs
- 2 Analog inputs:
  - ◆ AIN1: 0 – 10 V, 0 – 20 mA and -10 to +10 V
  - ◆ AIN2: 0 – 10 V, 0 – 20 mA
- The 2 analog inputs can be used as the 7<sup>th</sup> and 8<sup>th</sup> digital inputs
- BiCo technology
- Modular design for extremely flexible configuration
- High switching frequencies for low-noise motor operation
- Detailed status information and integrated message functions
- External options for PC communications, Basic Operator Panel (BOP-2) and PROFIBUS communications module
- Pump & Fan Features:
  - ◆ Motor Staging (Control of additional drives via output relay)
  - ◆ Energy Saving Mode
  - ◆ Hand / Auto (manual / automatic)
  - ◆ Belt failure detection (detects if pumps have run dry)
  - ◆ Bypass

### Performance Characteristics

- U/f control
  - ◆ Linear U/f control with flux current control (FCC) for improved dynamic response and motor control
  - ◆ Multiple point U/f control
- Fast Current Limitation (FCL) for trip-free operation
- Built-in DC injection brake
- Compound braking to improve braking performance
- Ramp function generator
  - ◆ With smoothing
  - ◆ Without smoothing
- Technology controller (PID)
- parameter set switch-over
  - ◆ Motor data sets (DDS)
  - ◆ Command data sets and setpoint sources (CDS)
- Rating for operation with variable torque (VT)
- Free Function Blocks

### Protection characteristics

- Overvoltage/undervoltage protection
- Overtemperature protection for the inverter
- Ground fault protection
- Short-circuit protection
- $i^2t$  thermal motor protection
- PTC/KTY for motor protection

## 2 Installation

**This Chapter contains:**

- General data relating to installation
- Dimensions of Inverter
- Wiring guidelines to minimize the effects of EMI
- Details concerning electrical installation

|     |  |    |
|-----|--|----|
| 2.1 | Installation after a Period of Storage ..... | 20 |
| 2.2 | Ambient operating conditions .....           | 22 |
| 2.3 | Mechanical installation.....                 | 24 |
| 2.4 | Electrical installation .....                | 29 |



---

**WARNING**

- Work on the device/system by **unqualified** personnel or failure to comply with warnings can result in severe personal injury or serious damage to material. Only suitably qualified personnel trained in the setup, installation, commissioning and operation of the product should carry out work on the device/system.
  - Only permanently-wired input power connections are allowed. This equipment must be grounded (IEC 536 Class 1, NEC and other applicable standards).
  - If a Residual Current-operated protective Device (RCD) is to be used, it must be an RCD type B. Machines with a three-phase power supply, fitted with EMC filters, must not be connected to a supply via an ELCB (Earth Leakage Circuit-Breaker EN 50178 Section 5.2.11.1).
  - The following terminals can carry dangerous voltages even if the inverter is inoperative:
    - ◆ the power supply L/L1, N/L2, L3 resp. U1/L1, V1/L2, W1/L3
    - ◆ the motor terminals U, V, W resp. U2/T1, V2/T2, W2/T3
    - ◆ and depending on the frame size the terminals DC+/B+, DC-, B-, DC/R+ resp. C/L+, D/L-.
  - Always wait **5 minutes** to allow the unit to discharge after switching off before carrying out any installation work.
  - This equipment must not be used as an 'emergency stop mechanism' (see *EN 60204, 9.2.5.4*).
  - The minimum size of the earth-bonding conductor must be equal to or greater than the cross-section of the power supply cables.
- 

**CAUTION**

The connection of power, motor and control cables to the inverter must be carried out as shown in Figure 2-13 on page 39, to prevent inductive and capacitive interference from affecting the correct functioning of the inverter.

---

## 2.1 Installation after a Period of Storage

Following a prolonged period of storage, you must reform the capacitors in the inverter. The requirements are listed below.

### Frame Sizes C to F

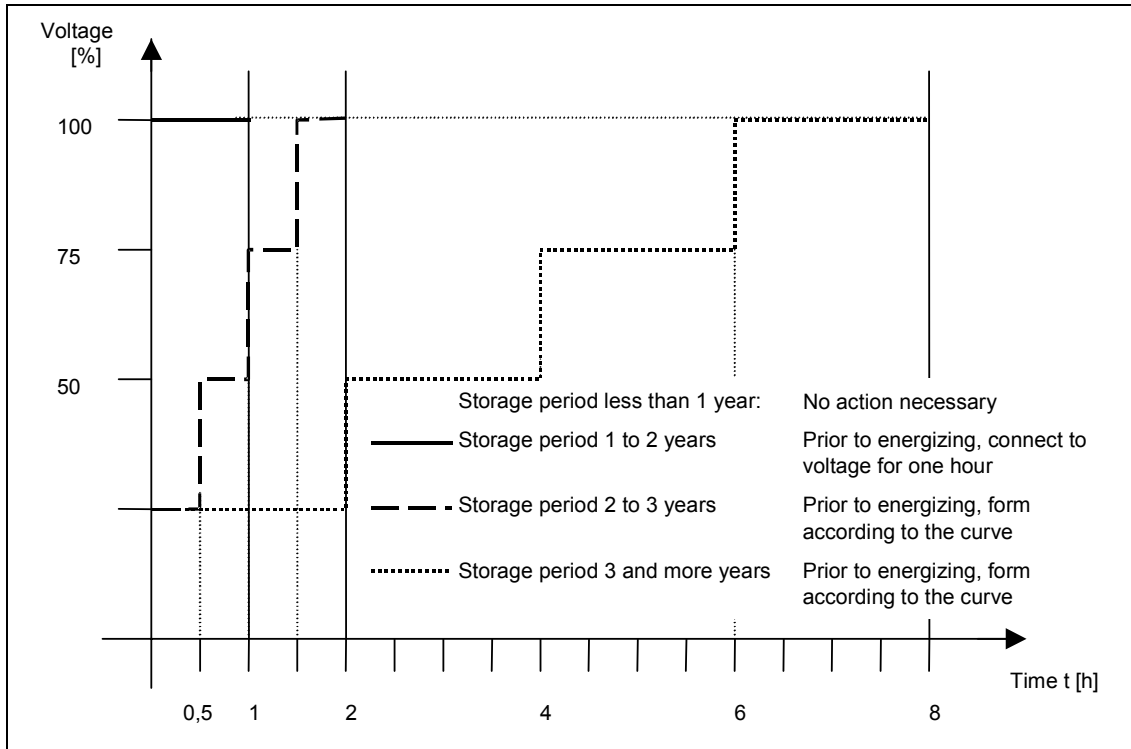

Figure 2-1 Forming

### Frame Sizes FX and GX

Reforming the capacitors can be accomplished by applying 85 % of the rated input voltage for at least 30 minutes without load.

## 2.2 Ambient operating conditions

### Temperature

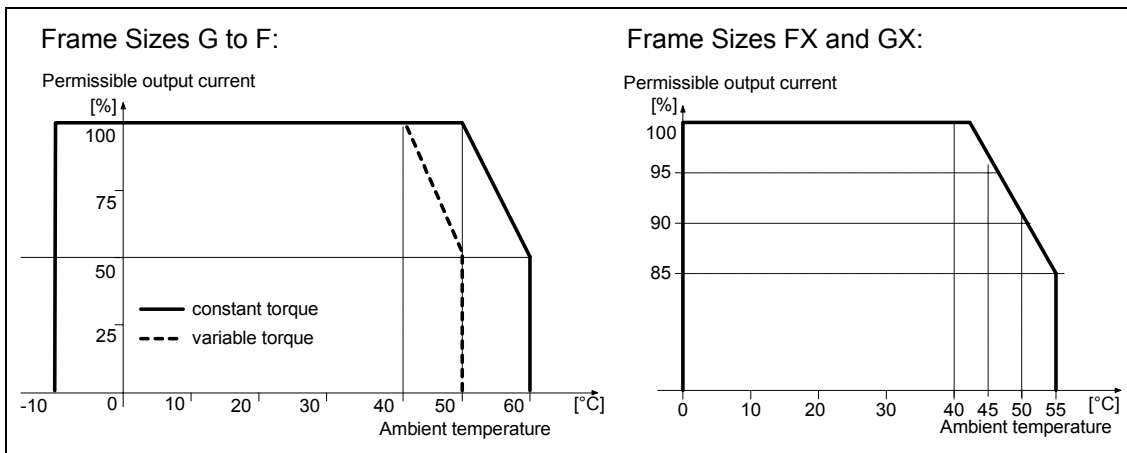

Figure 2-2 Ambient operating temperature

### Humidity Range

Relative air humidity ≤ 95 % Non-condensing

### Altitude

If the inverter is to be installed at an altitude > 1000 m or > 2000 m above sea level, derating will be required:

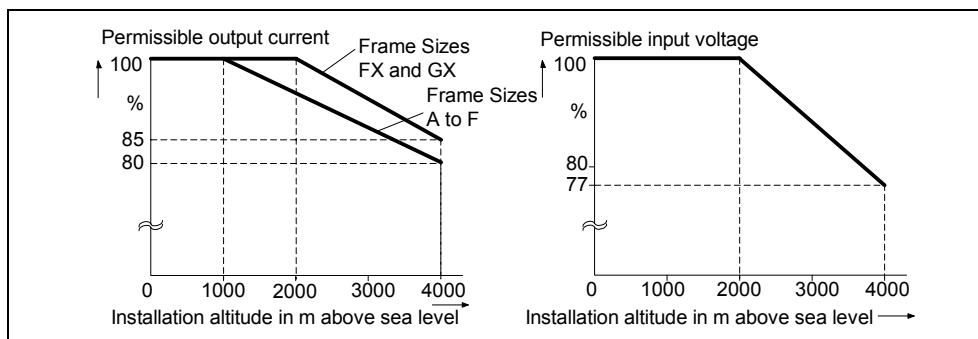

Figure 2-3 Installation altitude

### Shock and Vibration

Do not drop the inverter or expose to sudden shock. Do not install the inverter in an area where it is likely to be exposed to constant vibration.

Mechanical strength to DIN IEC 68-2-6

- Deflection: 0.075 mm (10 ... 58 Hz)
- Acceleration: 9.8 m/s<sup>2</sup> (> 58 ... 500 Hz)

### Electromagnetic Radiation

Do not install the inverter near sources of electromagnetic radiation.

### Atmospheric Pollution

Do not install the inverter in an environment, which contains atmospheric pollutants such as dust, corrosive gases, etc.

### Water

Take care to site the inverter away from potential water hazards, e.g. do not install the inverter beneath pipes that are subject to condensation. Avoid installing the inverter where excessive humidity and condensation may occur.

### Installation and cooling

---

#### CAUTION

The inverters **MUST NOT** be mounted horizontally.

The inverters can be mounted without any clearance at either side.

---

When mounting inverters one above the other, the specified environmental conditions must not be exceeded.

Independent of this, these minimum distances must be observed.

- Frame Size C           above and below 100 mm
- Frame Size D, E       above and below 300 mm
- Frame Size F           above and below 350 mm
- Frame Size FX, GX   above 250 mm  
                                  below 150 mm  
                                  in front 100 mm

No equipment that could have a negative effect on the flow of cooling air should be installed in this area. Make sure that the cooling vents in the inverter are positioned correctly to allow free movement of air.

## 2.3 Mechanical installation



### WARNING

- To ensure the safe operation of the equipment, it must be installed and commissioned by qualified personnel in full compliance with the warnings laid down in these operating instructions.
  - Take particular note of the general and regional installation and safety regulations regarding work on dangerous voltage installations (e.g. EN 50178), as well as the relevant regulations regarding the correct use of tools and personal protective equipment (PPE).
  - The mains input, DC and motor terminals, can carry dangerous voltages even if the inverter is inoperative; wait 5 minutes to allow the unit to discharge after switching off before carrying out any installation work.
  - The inverters can be mounted without any clearance at either side. When mounting inverters one above the other, the specified environmental conditions must not be exceeded. Independent of this, these minimum distances must be observed.
 

|                     |   |
|---------------------|---|
| ◆ Frame Size C      | above and below 100 mm                          |
| ◆ Frame Size D, E   | above and below 300 mm                          |
| ◆ Frame Size F      | above and below 350 mm                          |
| ◆ Frame Size FX, GX | above 250 mm<br>below 150 mm<br>in front 100 mm |
- 
- If the front cover (Frame Sizes FX and GX) has been removed, the fan impeller is exposed. There is danger of injury when the fan is running.

### Removing from transport pallet (only for framesizes FX and GX)

During transport, the inverter is fastened on the transport pallet with the aid of two iron brackets.



### WARNING

Note that the center of gravity of the inverter is not in the middle of the unit. When lifting the pallet, the unit can therefore suddenly change position and swing to the side.

1. Fasten the hoisting crane cable to the 2 hoisting eyes on the inverter (see Figure 2-9 for frame size FX, Figure 2-10 for frame size GX).
2. Remove the two retaining bolts at the top of the front cover.
3. Unscrew the bolts in the iron brackets on the transport pallet and lift the inverter off the pallet.
4. Once installation has been completed and the inverter connected, fasten the two retaining bolts for the front cover at the bottom side of the door.



Frame Sizes C to F

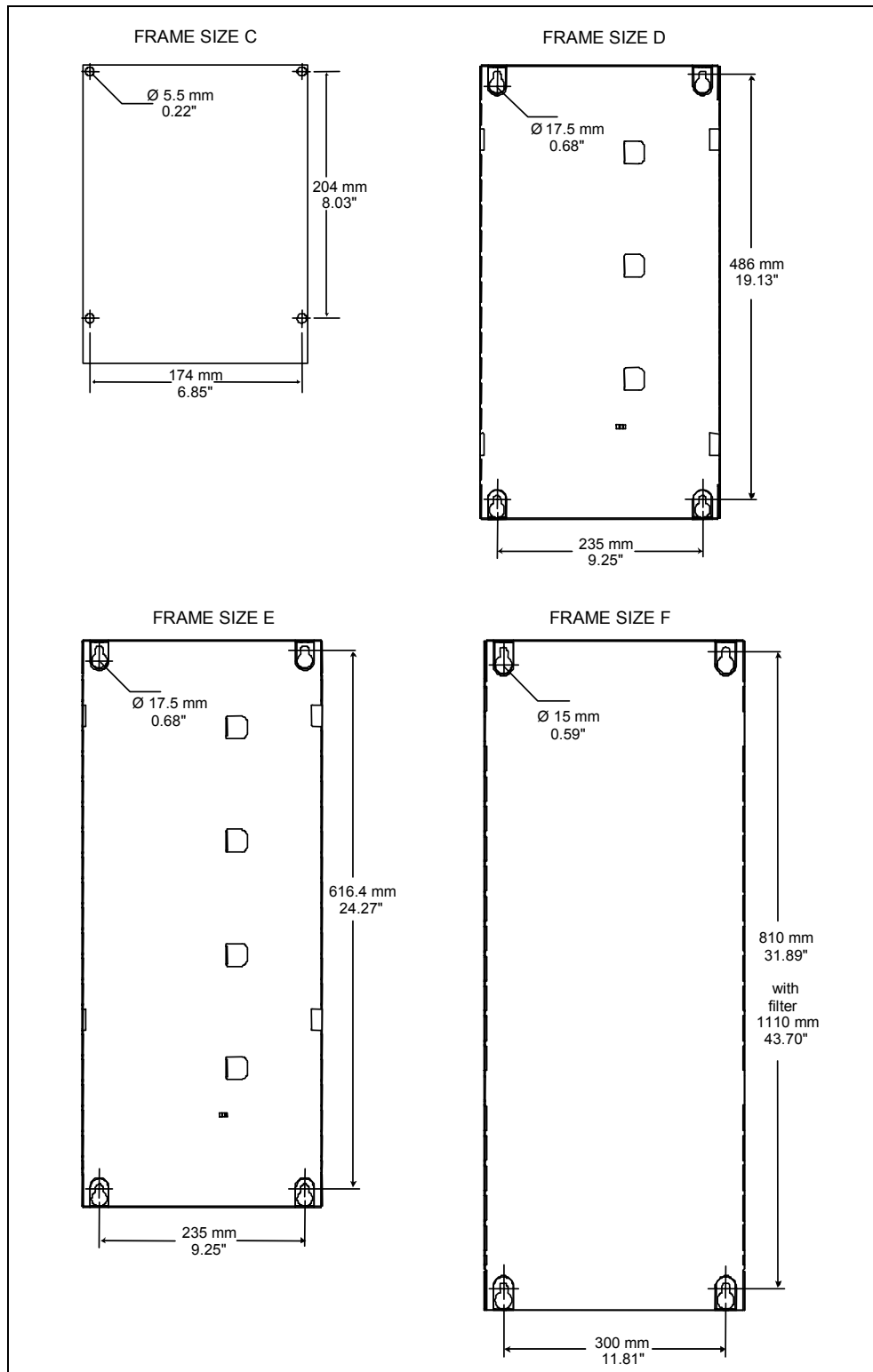

Figure 2-4 Drill pattern for MICROMASTER 430 Frame Sizes C to F

Frame Size FX

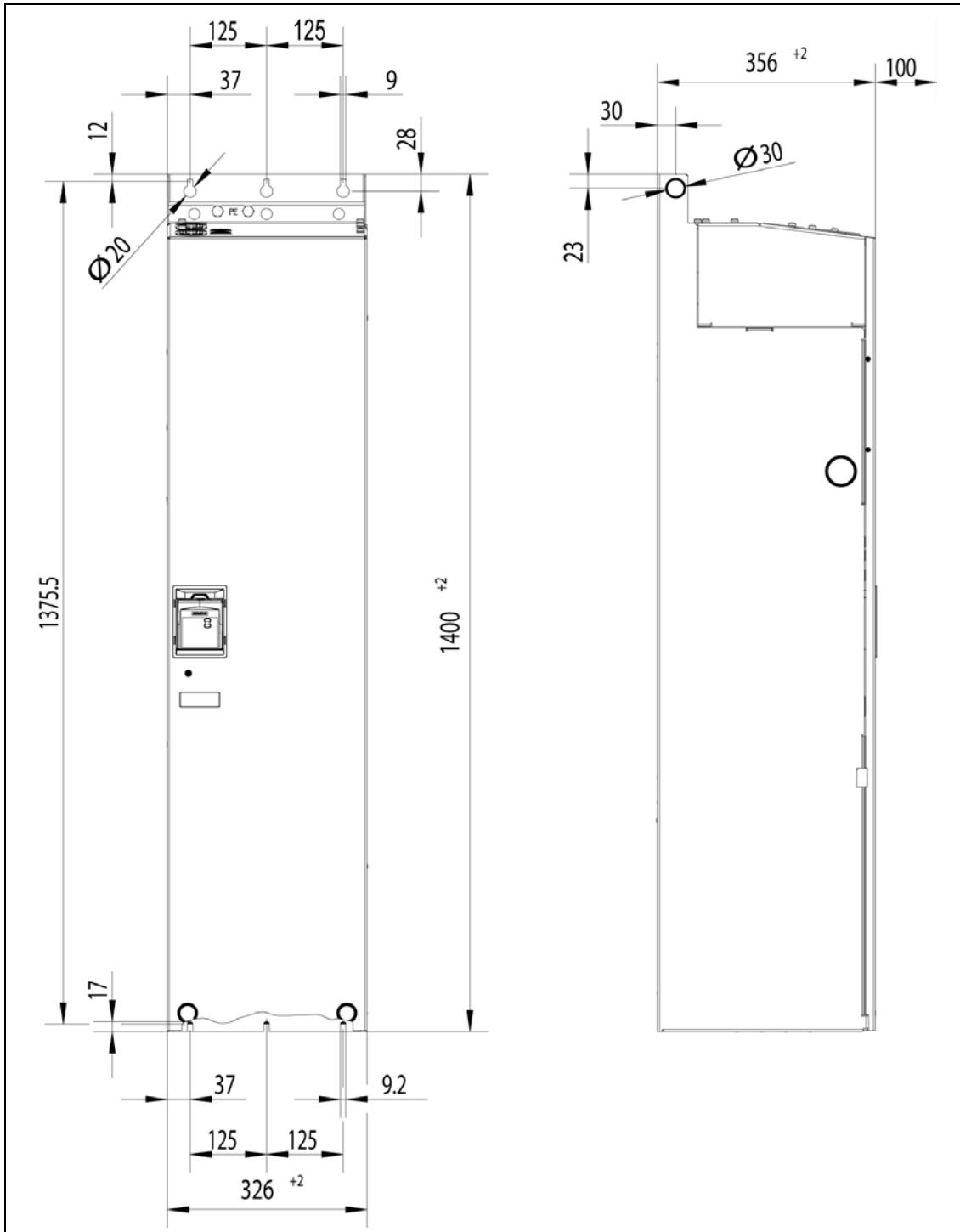

Figure 2-5 Installation dimensions for MICROMASTER 430 Frame size FX

**Frame Size GX**

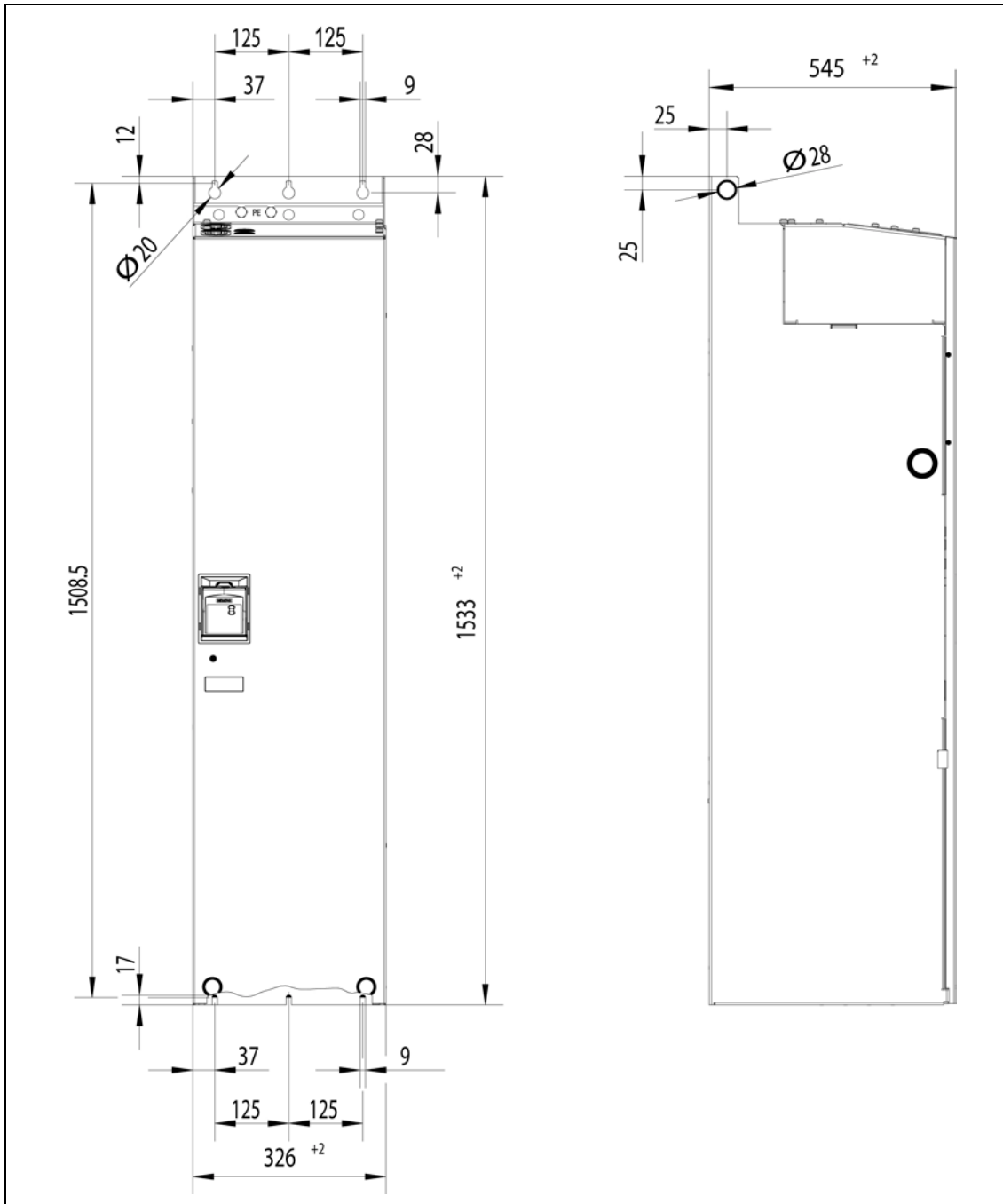

Figure 2-6 Installation dimensions for MICROMASTER 430 Frame size GX

**Table 2-1 Dimensions and Torques of MICROMASTER 430**

| Frame-Size |                              | Overall Dimensions |   | Fixing Method                                 | Tightening Torque                  |
|------------|------------------------------|--------------------|---|---|------------------------------------|
| <b>C</b>   | Width x<br>Height x<br>Depth | mm                 | 185 x 245 x 195                                   | 4 x M5 Bolts<br>4 x M5 Nuts<br>4 x M5 Washers | 2.5 Nm<br>with washers fitted      |
|            |                              | inch               | 7.28 x 9.65 x 7.68                                |   |                                    |
| <b>D</b>   | Width x<br>Height x<br>Depth | mm                 | 275 x 520 x 245                                   | 4 x M8 Bolts<br>4 x M8 Nuts<br>4 x M8 Washers | 3.0 Nm<br>with washers fitted      |
|            |                              | inch               | 10.82 x 20.47 x 9.65                              |   |                                    |
| <b>E</b>   | Width x<br>Height x<br>Depth | mm                 | 275 x 650 x 245                                   | 4 x M8 Bolts<br>4 x M8 Nuts<br>4 x M8 Washers | 3.0 Nm<br>with washers fitted      |
|            |                              | inch               | 10.82 x 25.59 x 9.65                              |   |                                    |
| <b>F</b>   | Width x<br>Height x<br>Depth | mm                 | 350 x 850 mm x 320<br>height with filter 1150     | 4 x M8 Bolts<br>4 x M8 Nuts<br>4 x M8 Washers | 3.0 Nm<br>with washers fitted      |
|            |                              | inch               | 13.78 x 33.46 x 12.60<br>height with filter 45.28 |   |                                    |
| <b>FX</b>  | Width x<br>Height x<br>Depth | mm                 | 326 x 1400 x 356                                  | 6 M 8 Bolts<br>6 M 8 Nuts<br>6 M 8 Washers    | 13 Nm +30 %<br>with washers fitted |
|            |                              | inch               | 12,80 x 55,12 x 12,83                             |   |                                    |
| <b>GX</b>  | Width x<br>Height x<br>Depth | mm                 | 326 x 1533 x 545                                  | 6 M 8 Bolts<br>6 M 8 Nuts<br>6 M 8 Washers    | 13 Nm +30 %<br>with washers fitted |
|            |                              | inch               | 12,80 x 60,35 x 21,46                             |   |                                    |

### 2.3.1 Installation of options in the electronic box, Frame Sizes FX and GX

The front cover of the MICROMASTER 440 is designed so that the control module (normally the SDP) is almost flush with the opening in the front cover. If more than one option is to be installed in the electronic box, it is necessary to position the entire electronic box further to the rear

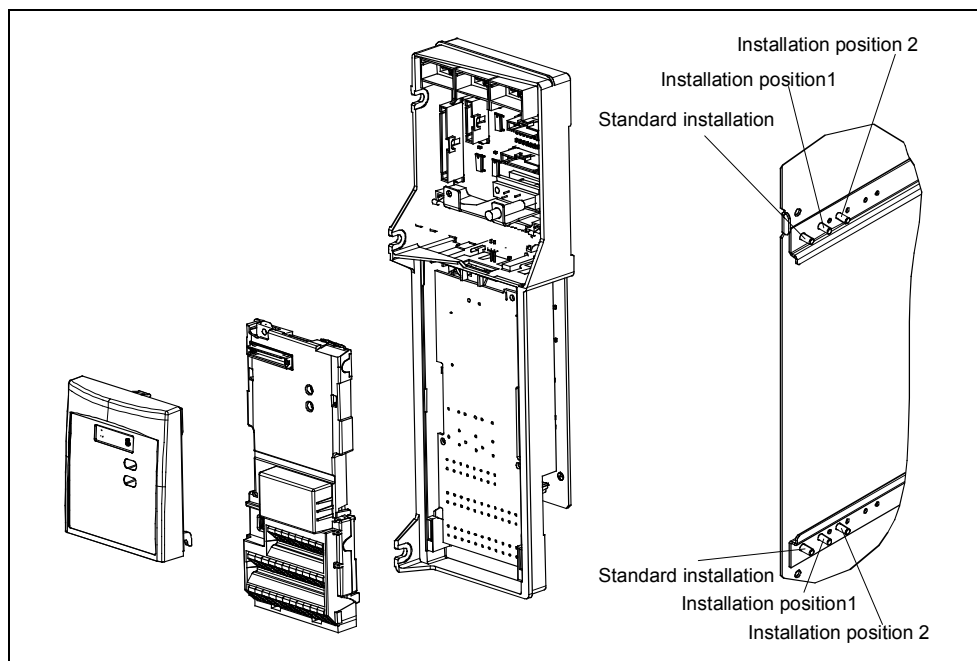

Figure 2-7 Options for the electronic box

#### Installing the options

- Remove the front cover:
  - Unscrew two screws at the bottom side of the front cover.
  - Lift front cover up and out.
- Remove retaining screws on the electronic box.
- Screw on electronic box in correct installation position as shown in Figure 2-7
- Install additional options.
- Reinstall front cover.

## 2.4 Electrical installation

---



### WARNING

- **The inverter must always be grounded.**
  - To ensure the safe operation of the equipment, it must be installed and commissioned by qualified personnel in full compliance with the warnings laid down in these operating instructions.
  - Take particular note of the general and regional installation and safety regulations regarding work on dangerous voltage installations (e.g. EN 50178), as well as the relevant regulations regarding the correct use of tools and personal protective gear.
  - Never use high voltage insulation test equipment on cables connected to the inverter.
  - The mains input, DC and motor terminals, can carry dangerous voltages even if the inverter is inoperative; wait **5 minutes** to allow the unit to discharge after switching off before carrying out any installation work.
  - If the front cover (Frame Sizes FX and GX) has been removed, the fan impeller is exposed. There is danger of injury when the fan is running.
- 

### CAUTION

The control, power supply and motor leads **must** be laid separately. Do not feed them through the same cable conduit/trunking.

---

### 2.4.1 General



#### WARNING

**The inverter must always be grounded.** If the inverter is not grounded correctly, extremely dangerous conditions may arise within the inverter which could prove potentially fatal.

#### Operation with ungrounded (IT) supplies

The use of MICROMASTER 4 inverters with built in filters is not allowed on IT supplies.

On ungrounded supplies, it will be necessary to remove the 'Y' capacitor from the inside of the unit. The procedure for removing this capacitor is described in Appendices D.

The MICROMASTER will operate from ungrounded supplies and will continue to operate if an input phase is shorted to ground. If an output phase is shorted to ground, the MICROMASTER will trip and indicate F0001.

#### Operation with Residual Current Device (Frame Sizes C to F)

If an RCD (also referred to as ELCB or RCCB) is fitted, the MICROMASTER inverters will operate without nuisance tripping, provided that:

- A type B RCD is used.
- The trip limit of the RCD is 300 mA.
- The neutral of the supply is grounded.
- Only one inverter is supplied from each RCD.
- The output cables are less than 50 m (screened) or 100m (unscreened).

#### Operation with long cables

All inverters will operate at full specification with cable lengths as follows:

##### Frame Sizes C to F

- screened: 50 m
- unscreened: 100 m

##### Frame Sizes FX and GX

- screened: 100 m
- unscreened: 150 m

Using the output chokes specified in catalogue DA 51.2, the following cable lengths are possible for all frame sizes:

- screened: 200 m
- unscreened: 300 m

## 2.4.2 Power and motor connections

---



### WARNING

**The inverter must always be grounded.**

- Isolate the mains electrical supply before making or changing connections to the unit.
  - When synchronous motors are connected or when coupling several motors in parallel, the inverter must be operated with voltage/frequency control characteristic (P1300 = 0, 2 or 3).
- 



### CAUTION

After connecting the power and motor cables to the proper terminals, make sure that the front covers have been replaced properly before supplying power to the unit!

---

### NOTICE

- Ensure that the appropriate circuit-breakers/fuses with the specified current rating are connected between the power supply and inverter (see *chapter 7, Tables starting on page 105*).
  - Use Class 1 60/75 °C copper wire only (for UL compliance). For tightening torque see Table 7-2 on page 105.
- 

## Access to the power and motor terminals

Access to the power supply and motor terminals is possible by removing the front covers (See Figure 2-8 to Figure 2-10). See also Appendix B

After removing the front covers and exposing the terminals, complete power and motor connections as shown Figure 2-11.



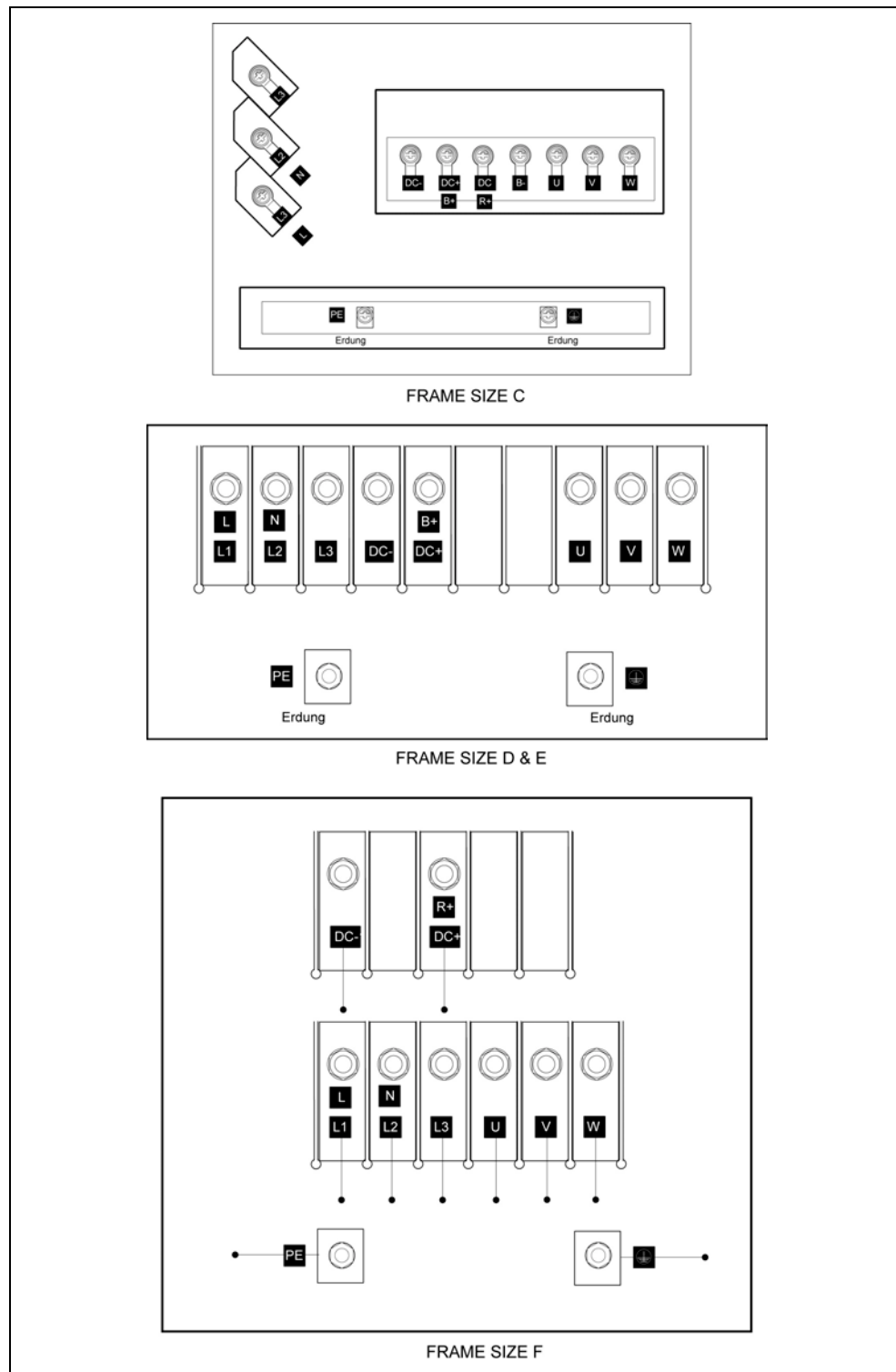

Figure 2-8 MICROMASTER 430 Connection Terminals, Frame Sizes C to F

**NOTE**

The DC connections are for testing purposes only and have not been released for operation by the user. No brake resistors etc. may be connected here.

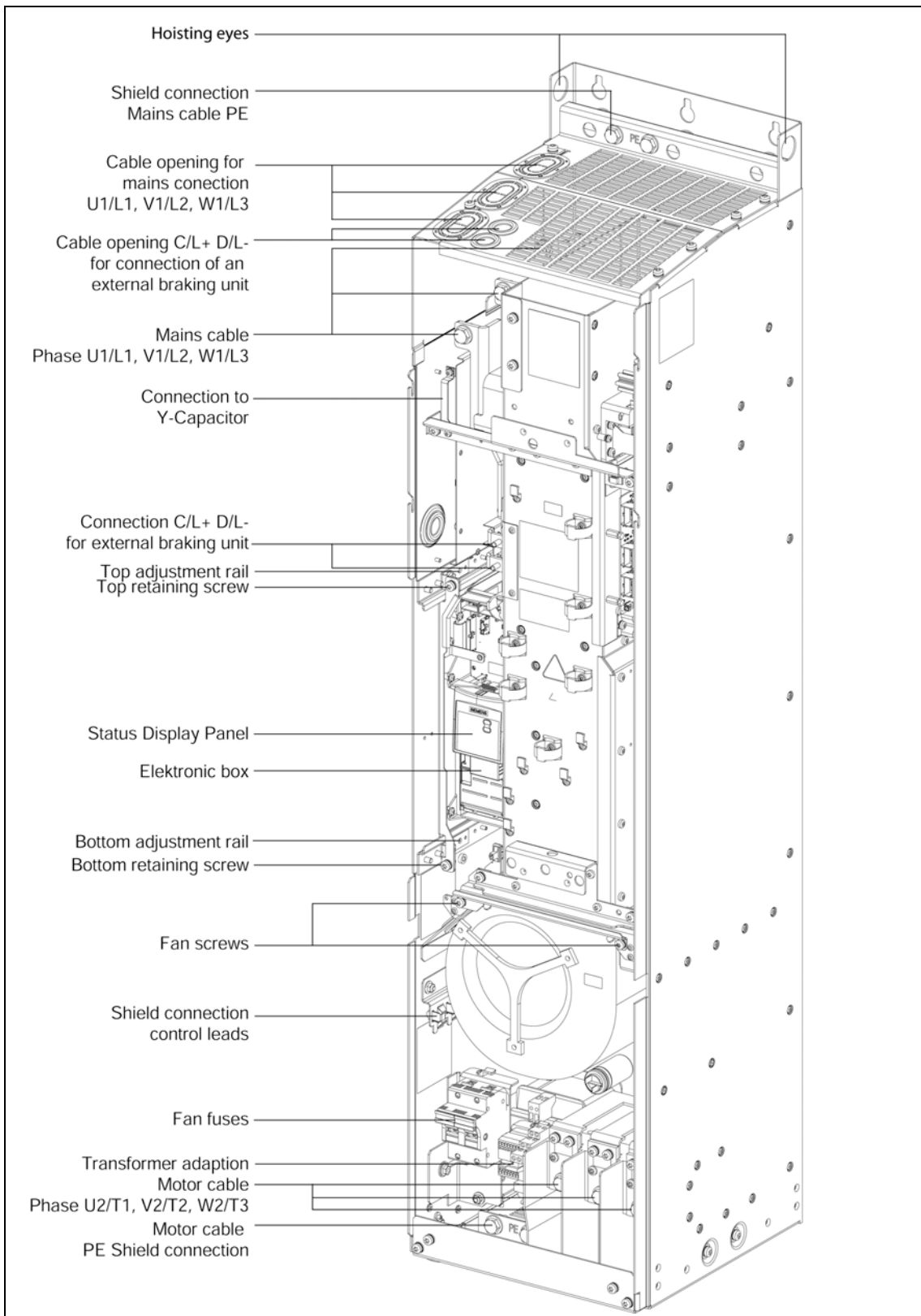

Figure 2-9 MICROMASTER 430 connection drawing – frame size FX

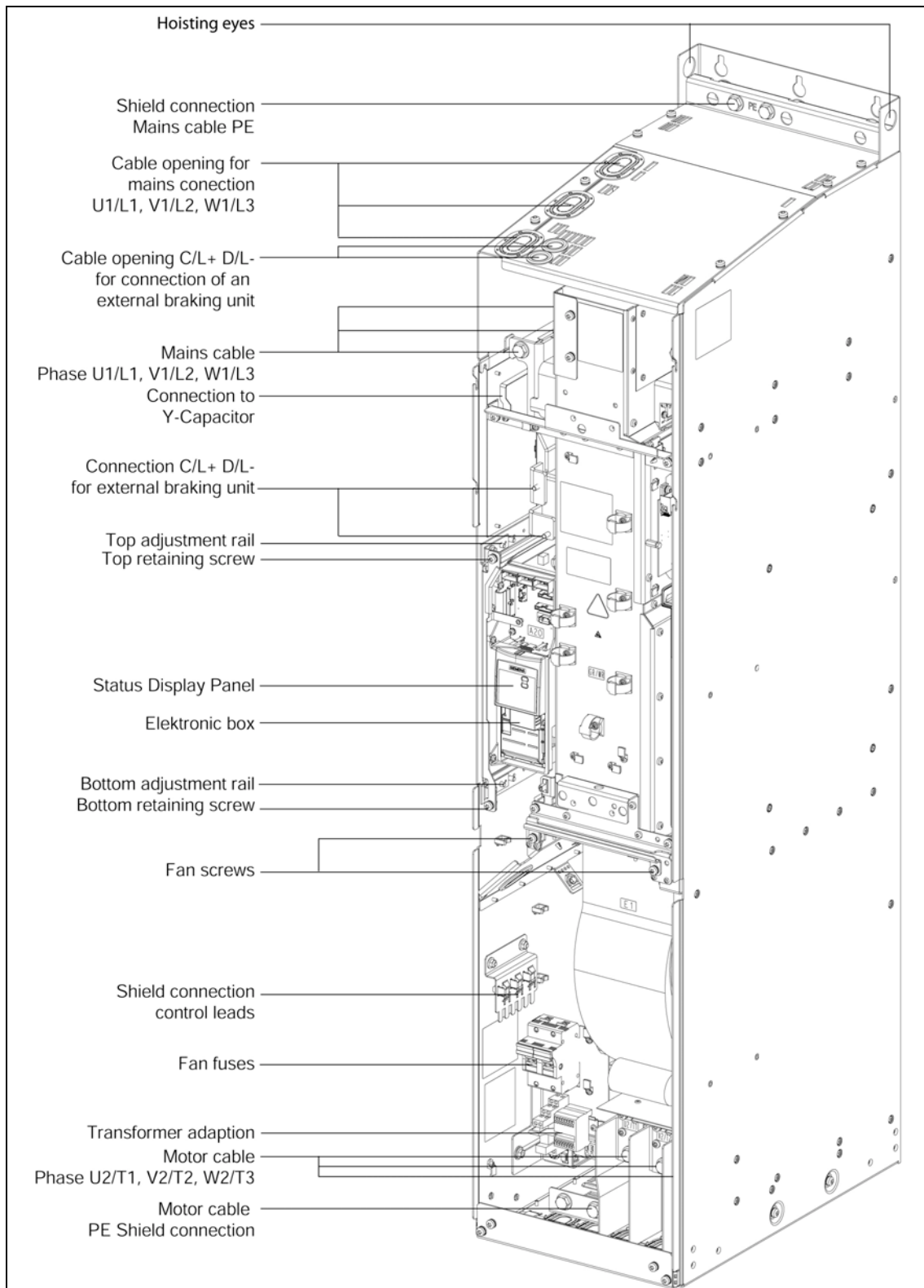
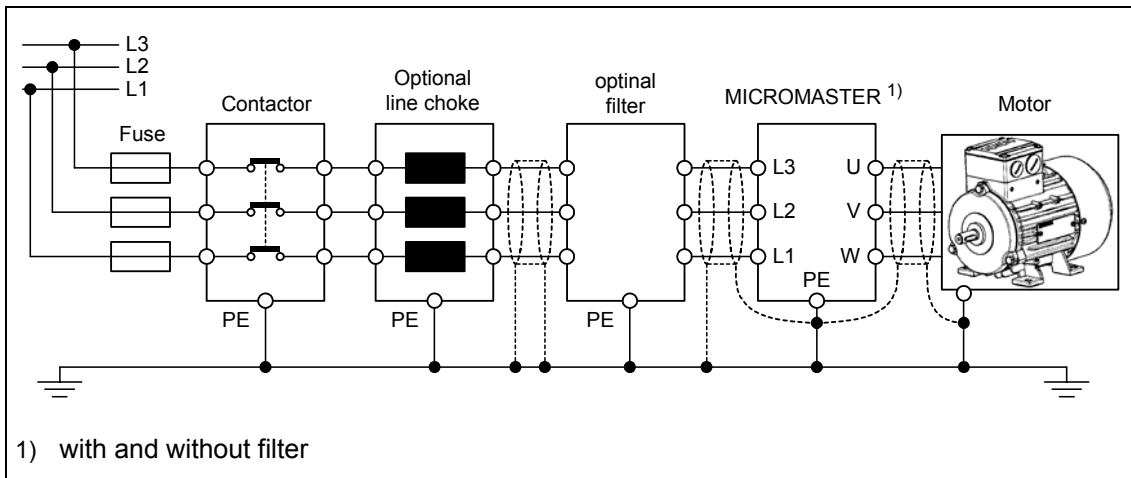

Figure 2-10 MICROMASTER 430 connection drawing – frame size GX

**Frame Sizes C to F**



**Frame Sizes FX and GX**

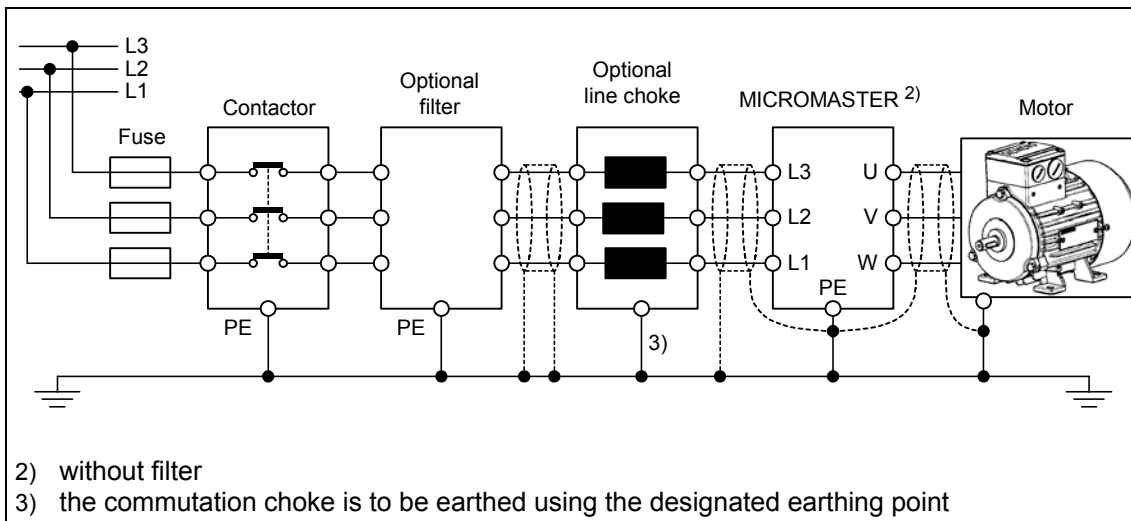

Figure 2-11 Motor and Power Connections

**Adaptation of fan voltage (only for framesize FX and GX)**

A transformer is installed to adapt the existing line voltage to the fan voltage. It may be necessary to reconnect the transformer terminals on the primary side to coincide with the existing line power.

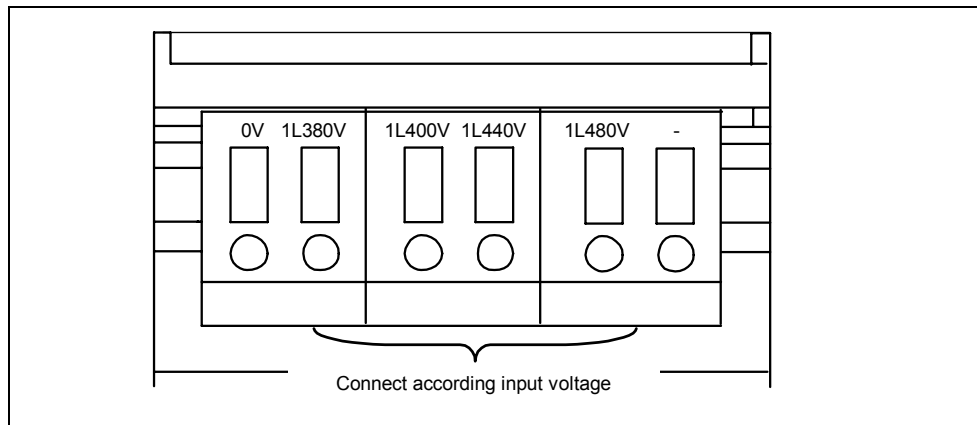

Figure 2-12 Adaptation of fan voltage

**CAUTION**

If the terminals are not reconnected to the actually present line voltage, the fan fuses can blow.

**Replacement for fan fuses**

| Frame size         | Fuses (2 each) | Typ                                   |
|--------------------|----------------|---------------------------------------|
| FX (110 kW VT)     | 1 A            | Cooper-Bussmann FNQ-R-1, 600 V        |
| FX (132 kW VT)     | 2,5 A          | Ferraz Gould Shawmut ATDR2-1/2, 600 V |
| GX (160-250 kW VT) | 4 A            | Ferraz Gould Shawmut ATDR4, 600 V     |

### 2.4.3 Avoiding Electro-Magnetic Interference (EMI)

The inverters are designed to operate in an industrial environment where a high level of EMI can be expected. Usually, good installation practices will ensure safe and trouble-free operation. If you encounter problems, follow the guidelines stated below.

#### Action to Take

- Ensure that all equipment in the cubicle is well grounded using short, thick grounding cable connected to a common star point or busbar.
- Make sure that any control equipment (such as a PLC) connected to the inverter is connected to the same ground or star point as the inverter via a short thick link.
- Connect the return ground from the motors controlled by the inverters directly to the ground connection (PE) on the associated inverter.
- Flat conductors are preferred as they have lower impedance at higher frequencies.
- Terminate the ends of the cable neatly, ensuring that unscreened wires are as short as possible.
- **Separate the control cables from the power cables as much as possible, using separate trunking, if necessary at 90° to each other.**
- Whenever possible, use screened leads for the connections to the control circuitry.
- Ensure that the contactors in the cubicle are suppressed, either with R-C suppressors for AC contactors or 'flywheel' diodes for DC contactors fitted to the coils. Varistor suppressors are also effective. This is important when the contactors are controlled from the inverter relay.
- Use screened or armored cables for the motor connections and ground the screen at both ends using the cable clamps.



---

#### WARNING

Safety regulations **must not** be compromised when installing inverters!

---

## 2.4.4 Screening Methods

### Frame Size C

For frame size C the Gland Plate Kit is supplied as an option. It allows easy and efficient connection of the necessary screening. See the Gland Plate Installation Instructions contained on the Document CD-ROM, supplied with the MM430.

### Screening without a Gland Plate

Should a Gland Plate not be available, then the inverter can be screened using the methodology shown in Figure 2-13.

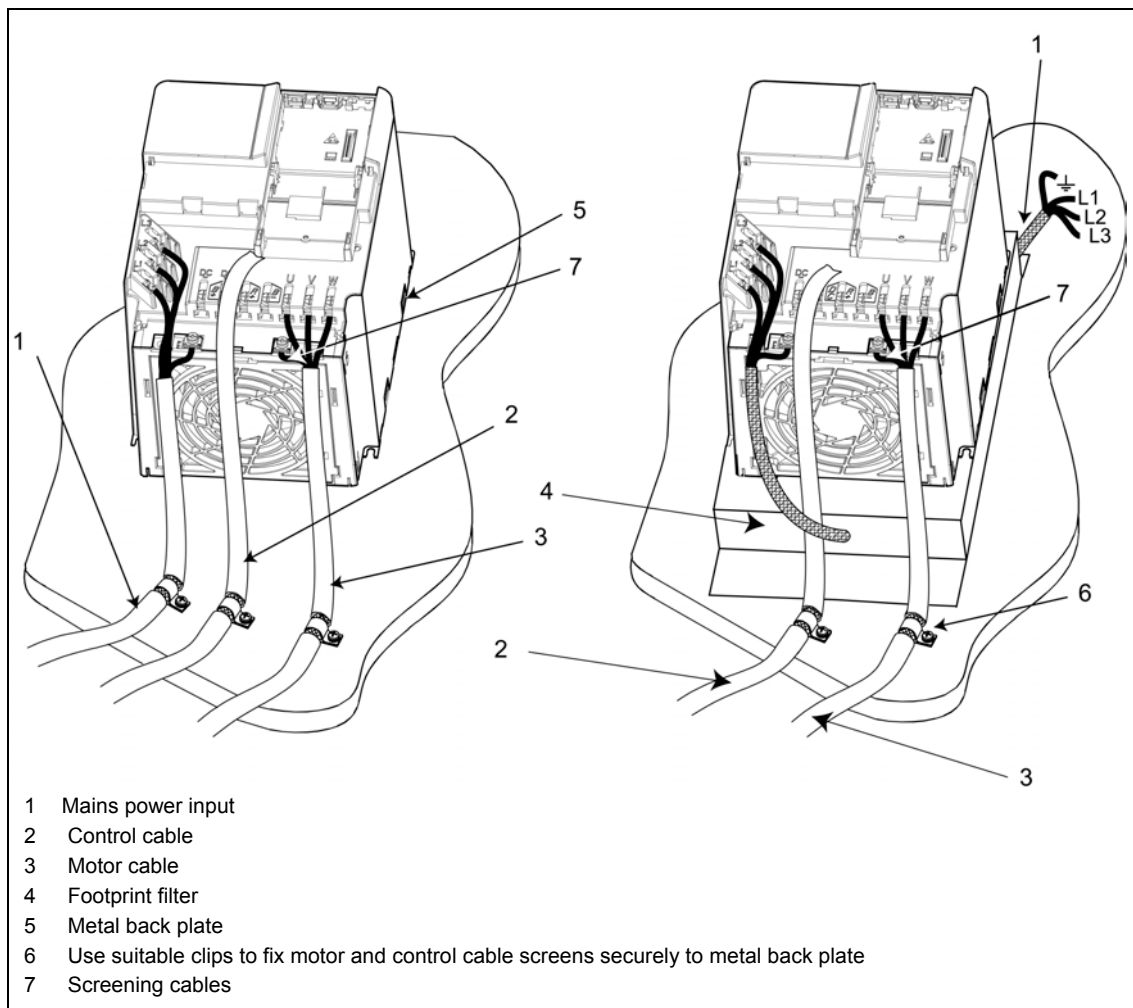

Figure 2-13 Wiring Guidelines to Minimize the Effects of EMI

### Frame Sizes D, E and F

The Gland Plate is factory fitted. The installation of the screening is accomplished using the same methodology as in frame size C.

**Frame Sizes FX and GX**

Connect the wire shields to the shield connection points shown in the connection drawing (see Figure 2-9 and Figure 2-10) .

For this purpose twist the motor leads and screw all of them together to the shield connection point for the motor lead.

When using an EMI filter, a power commutating choke is required. The wire shields should be fastened to the metallic mounting surface as close as possible to the components.



## 3 Commissioning

### This Chapter contains:

- A schematic diagram of the MICROMASTER 430
- An overview of the commissioning options and the display and operator panels
- An overview of quick commissioning of the MICROMASTER 430

|     |                         |           |
|-----|-------------------------|-----------|
| 3.1 | Block diagram .....     | 43        |
| 3.2 | Commission modes .....  | 44        |
| 3.3 | General operation ..... | <b>56</b> |



---

**WARNING**

- MICROMASTERS operate at high voltages.
  - When operating electrical devices, it is impossible to avoid applying hazardous voltages to certain parts of the equipment.
  - Emergency Stop facilities according to EN 60204 IEC 204 (VDE 0113) must remain operative in all operating modes of the control equipment. Any disengagement of the Emergency Stop facility must not lead to uncontrolled or undefined restart.
  - Wherever faults occurring in the control equipment can lead to substantial material damage or even grievous bodily injury (i.e. potentially dangerous faults), additional external precautions must be taken or facilities provided to ensure or enforce safe operation, even when a fault occurs (e.g. independent limit switches, mechanical interlocks, etc.).
  - Certain parameter settings may cause the inverter to restart automatically after an input power failure.
  - Motor parameters must be accurately configured for motor overload protection to operate correctly.
  - This equipment is capable of providing internal motor overload protection in accordance with UL508C section 42. Refer to P0610 and P0335,  $i^2t$  is ON by default. Motor overload protection can also be provided using an external PTC (disabled by default P0601).
  - This equipment is suitable for use in a circuit capable of delivering not more than 10,000 symmetrical amperes (rms), for a maximum voltage of 460 V when protected by a H or K type fuse (see *Tables starting on page 105*).
  - This equipment must not be used as an 'emergency stop mechanism' (see *EN 60204, 9.2.5.4*).
- 



---

**CAUTION**

Only qualified personnel may enter settings in the control panels. Particular attention must be paid to safety precautions and warnings at all times.

---

### 3.1 Block diagram

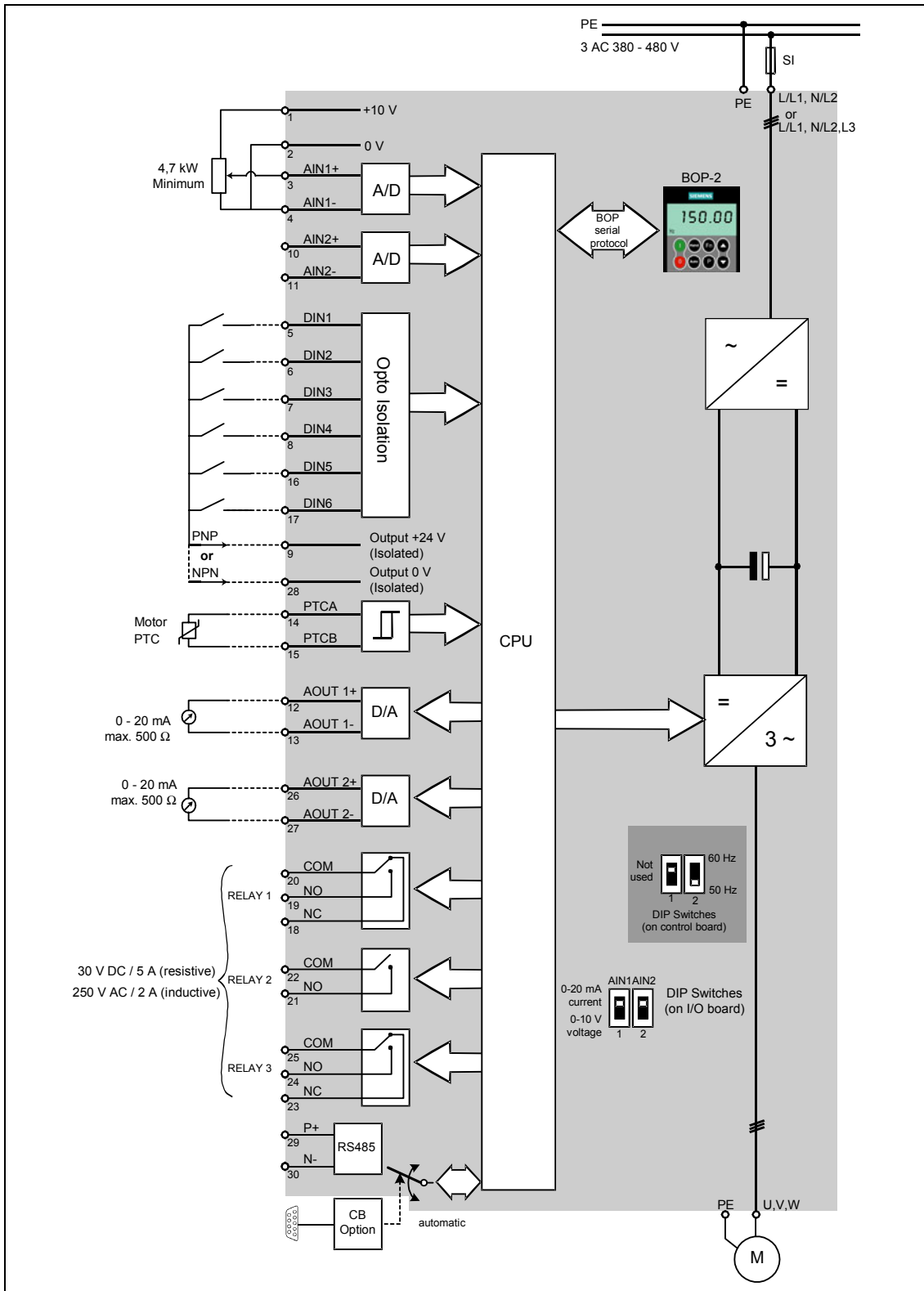

Figure 3-1 Inverter block diagram

### 3.1.1 Standard settings for the terminals

See Figure 3-2.

### 3.1.2 Analogue inputs

Analogue input 1 (AIN1) can be used with:

0 - 10 V, 0 - 20 mA and -10 V to +10 V

Analogue input 2 (AIN2) can be used with:

0 - 10 V and 0 - 20 mA

The analog input circuit can be alternatively configured to provide additional digital inputs (DIN7 & DIN8) as shown:

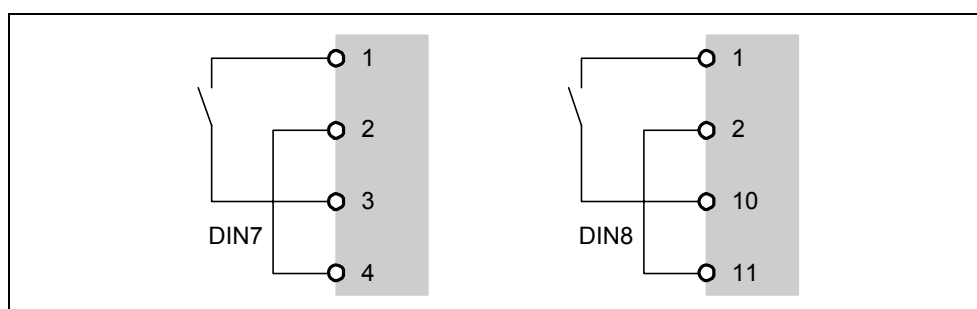

Figure 3-2 Configuration of the analogue input as a digital input

When an analogue input is configured as a digital input the threshold values are as follows:

1.75 V DC = OFF

3.70 V DC = ON

Terminal 9 (24 V) can also be used to drive the analog inputs when used as digital inputs. Terminals 2 and 28 (0 V) must be linked together.

## 3.2 Commission modes

In the standard version, the MICROMASTER 430 is fitted with the Status Display Panel (SDP) (see Figure 3-3) with which it is possible to use the inverter with the pre-assigned factory settings for a large range of applications. If these factory settings are not suitable, you can adapt them to suit your equipment conditions using the Basic Operator Panel-2 (BOP-2) (see Figure 3-3). The BOP-2 are available as options. You can also adjust the factory settings using the PC IBN tool. This software is available on the CD ROM which comes with the documentation of the unit.

### ATTENTION

MICROMASTER 430 can only be operated with the BOP-2.  
It is not possible to use BOP or AOP.

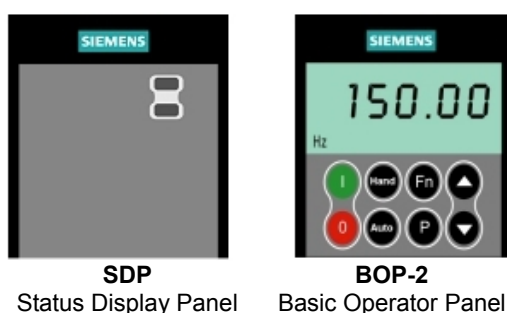

Figure 3-3 Panels available for the MICROMASTER 430 Inverter

For notes on replacing the operator panels please refer to the corresponding appendix A to this manual.

### NOTICE

Adjusting the motor frequency 50/60 Hz: The DIP switch to adjust the motor frequency is located below the I/O board (for removing the I/O board, see appendix C)

The inverter is delivered as follows:

- DIP switch 2:
  - ◆ Off position: European defaults (50 Hz, kW etc.)
  - ◆ On position: North American defaults (60 Hz, hp etc.)
- DIP switch 1:
  - Not for customer use.

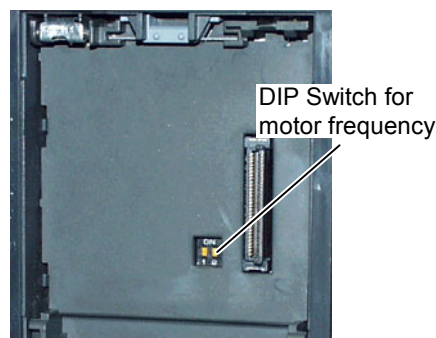
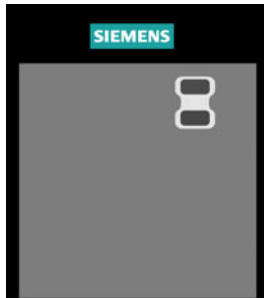

Figure 3-4 DIP switch

### 3.2.1 Commissioning with the SDP



The SDP has two LEDs on the front which display the current operating status of the inverter (see Section 6.1).

When the SDP is used, the presettings of the inverter must be compatible with the following motor data:

- Rated motor power
- Motor voltage
- Rated motor current
- Rated motor frequency

(A conventional Siemens motor is recommended)

In addition, the following conditions must be met:

- Linear V/f motor speed controlled by an analog potentiometer.
- Maximum speed 1500 rpm at 50 Hz (1800 rpm at 60 Hz); can be controlled by a potentiometer via the analog inputs of the inverter.
- Ramp-up time = 10 s
- Ramp-down time = 30 s

Settings for more complex applications can be found in the parameter list and in Section 3.2.2 "Commission Overview with BOP-2".

Table 3-1 Default settings for operation using the SDP

|                   | Terminals | Parameter    | Default Operation |
|-------------------|-----------|--------------|-------------------|
| Digital Input 1   | 5         | P0701 = '1'  | ON right          |
| Digital Input 2 * | 6         | P0702 = '12' | Reverse           |
| Digital Input 3   | 7         | P0703 = '9'  | Fault Acknowledge |
| Digital Input 4   | 8         | P0704 = '15' | Fixed Frequency   |
| Digital Input 5   | 16        | P0705 = '15' | Fixed Frequency   |
| Digital Input 6   | 17        | P0706 = '15' | Fixed Frequency   |
| Digital Input 7   | Via AIN1  | P0707 = '0'  | Inactive          |
| Digital Input 8   | Via AIN2  | P0708 = '0'  | Inactive          |

\* The standard setting for the change of rotation direction is as inhibited. (Parameter 1110)

### Basic operation with SDP

With the SDP fitted, the following is possible:

- Start and stopping the motor (DIN1 via external switch)
- Fault Reset (DIN3 via external switch)

Controlling the speed of the motor is accomplished by connecting the analog inputs as shown in the Figure 3-5.

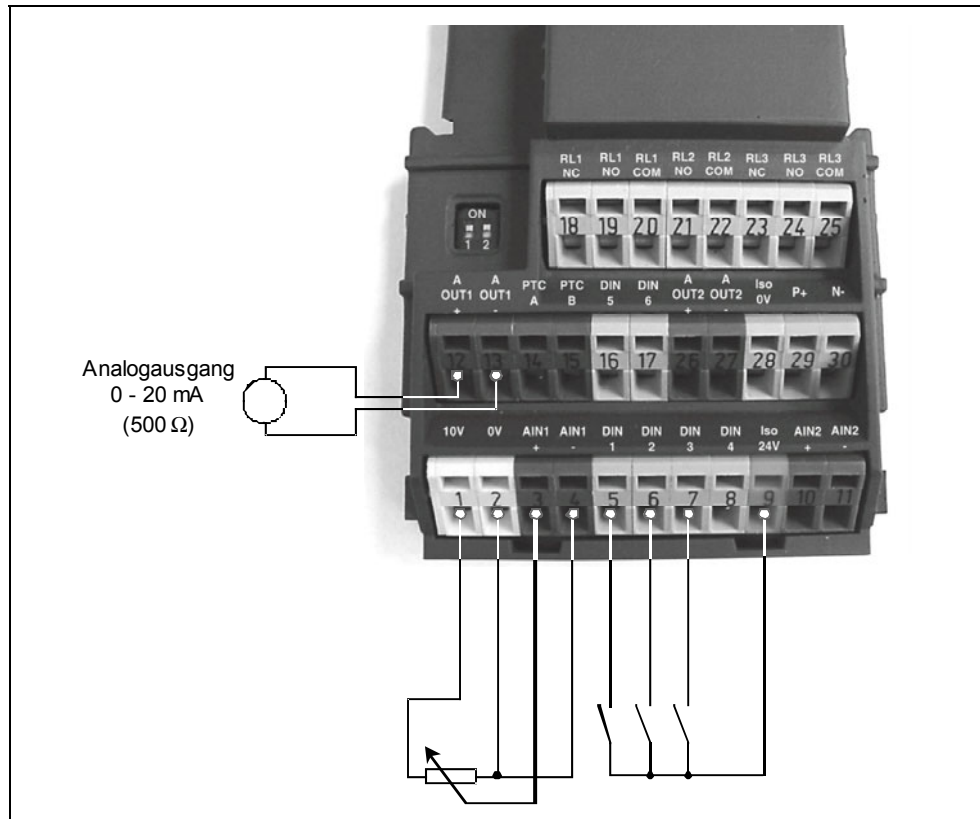
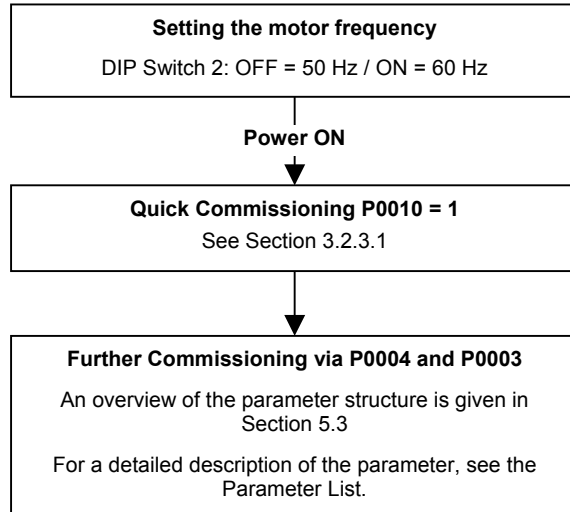

Figure 3-5 Basic operation with SDP

### 3.2.2 Commission Overview with BOP-2

#### Prerequisites

Mechanical and electrical Installation are completed.



---

#### NOTES

We recommend the commissioning according this scheme.

---



### 3.2.2.1 Commissioning with the BOP-2

You can alter parameter values via the BOP-2. To set parameters on this panel, you must remove the SDP and attach the BOP-2 (see Appendix A).



The BOP-2 features a five-digit, seven-segment display for showing parameter numbers and values, alarm and fault messages and setpoints and actual values. Parameter sets cannot be saved via the BOP-2.

Table 3-2 shows the factory default settings for operation via the BOP-2.

#### NOTICE

- The BOP-2 motor control functions are disabled by default. To control the motor via the BOP-2, parameter P0700 should be set to 1 and P1000 set to 1.
- The BOP-2 can be fitted to and removed from the inverter whilst power is applied.
- If the BOP-2 has been set as the I/O control (P0700 = 1), the drive will stop if the BOP-2 is removed.

Table 3-2 Default settings for operation using the BOP-2

| Parameter | Meaning                  | Default Europe (North America)  |
|-----------|--------------------------|---|
| P0100     | Operating Mode Europe/US | 50 Hz, kW (60 Hz, hp)   |
| P0307     | Power (rated motor)      | Dimension kW (Hp) depending on setting of P0100. [Value depending on variant] |
| P0310     | Motor frequency rating   | 50 Hz (60 Hz)   |
| P0311     | Motor speed rating       | 1395 (1680) rpm [depending on variant]  |
| P1082     | Maximum Motor Frequency  | 50 Hz (60 Hz)   |

#### ATTENTION

MICROMASTER 430 can only be operated using a BOP-2.

If a BOP or AOP is used, the following is shown on the display -----.

## Buttons on the BOP-2

















| Panel/Button  | Function          | Effects  |
|---|-------------------|--|
|    | Indicates Status  | The LCD displays the settings currently used by the converter.   |
|    | Start motor       | Pressing the button starts the converter. This button is disabled by default. To enable this button set P0700 = 1.   |
|    | Stop motor        | OFF1 Pressing the button causes the motor to come to a standstill at the selected ramp down rate. Disabled by default; to enable set P0700 = 1.<br>OFF2 Pressing the button twice (or once long) causes the motor to coast to a standstill. This function is always enabled.   |
|    | Manual mode       | The customer terminal strip (CD S2) and the operating panel (BOP-2) are sources for commands and set values  |
|    | Automatic mode    | The customer's terminal strip (CD S1) or the serial (US S) or field bus interface (e.g. PROFIBUS) are sources for commands and set values.   |
|  | Functions         | This button can be used to view additional information.<br>Pressing and holding the button for 2 seconds from any parameter during operation, shows the following:<br>1. DC link voltage (indicated by d – units V).<br>2. Output current. (A)<br>3. Output frequency (Hz)<br>4. Output voltage (indicated by o – units V).<br>5. The value selected in P0005 (If P0005 is set to show any of the above (1 - 4) then this will not be shown again).<br>Additional presses will toggle around the above displays.<br><b>Jump Function</b><br>From any parameter (rXXXX or PXXXX) a short press of the Fn button will immediately jump to r0000, you can then change another parameter, if required. Upon returning to r0000, pressing the Fn button will return you to your starting point.<br><b>Quit</b><br>In case of a fault or alarm the  button resets the fault or alarm message on the operator panel display. |
|  | Access parameters | Pressing this button allows access to the parameters.  |
|  | Increase value    | Pressing this button increases the displayed value.  |
|  | Decrease value    | Pressing this button decreases the displayed value.  |

Figure 3-6 Buttons on the BOP-2

### Changing parameters with the BOP-2

The procedure for changing the value of parameter P0004 is described below. Modifying the value of an indexed parameter is illustrated using the example of P0719. Follow exactly the same procedure to alter other parameters that you wish to set via the BOP-2.

#### Changing P0004 – parameter filter function

| Step   | Result on display |
|--|-------------------|
| 1 Press  to access parameters   | r0000             |
| 2 Press  until P0004 is displayed   | P0004             |
| 3 Press  to access the parameter value level  | 0                 |
| 4 Press  or  to the required value | 7                 |
| 5 Press  to confirm and store the value   | P0004             |

#### Changing P0719 an indexed parameter Selection of command/setpoint source









| Step   | Result on display |
|--|-------------------|
| 1 Press  to access parameters   | r0000             |
| 2 Press  until P0719 is displayed   | P0719             |
| 3 Press  to access the parameter value level  | r0000             |
| 4 Press  to display current set value   | 0                 |
| 5 Press  or  to the required value | 12                |
| 6 Press  to confirm and store the value   | P0719             |
| 7 Press  until r0000 is displayed   | r0000             |
| 8 Press  to return the display to the standard drive display (as defined by the customer)                             |                   |

Figure 3-7 Changing parameters via the BOP-2





**NOTES**

In some cases - when changing parameter values - the display on the BOP-2 shows **buSY**. This means the inverter is busy with tasks of higher priority.

**Changing single digits in Parameter values**

For changing the parameter value rapidly, the single digits of the display can be changed by performing the following actions:

Ensure you are in the parameter value changing level (see "Changing parameters with BOP-2").

1. Press  (function button), which causes the right hand digit to blink.
2. Change the value of this digit by pressing  / .
3. Press  (function button) again causes the next digit to blink.
4. Perform steps 2 to 4 until the required value is displayed.
5. Press the  to leave the parameter value changing level.

**NOTES**

The function button may also be used to acknowledge a fault condition

**3.2.3 Commissioning functions with BOP-2****3.2.3.1 Quick commissioning (P0010=1)**

Mechanical and electrical installation of the inverter must be completed before running „Quick Commissioning“.

It is **important** that parameter P0010 is used for commissioning and P0003 is used to select the access level.

There are three user levels, standard, extended and expert. The lower the access level fewer parameters can be seen while performing Quick commissioning. The values for these parameters are either the default settings or are calculated during quick commissioning.

Quick commissioning includes motor and ramp setting parameters.

Quick Commissioning concludes with P3900, which, when set to 1, will perform the necessary motor calculations and clear all other parameters (not included in P0010 = 1) to the default settings. After completing Quick Commissioning with P3900 = 1, the inverter is then ready to run; this will only happen in the Quick Commissioning mode.

**Flow chart Quick Commissioning**

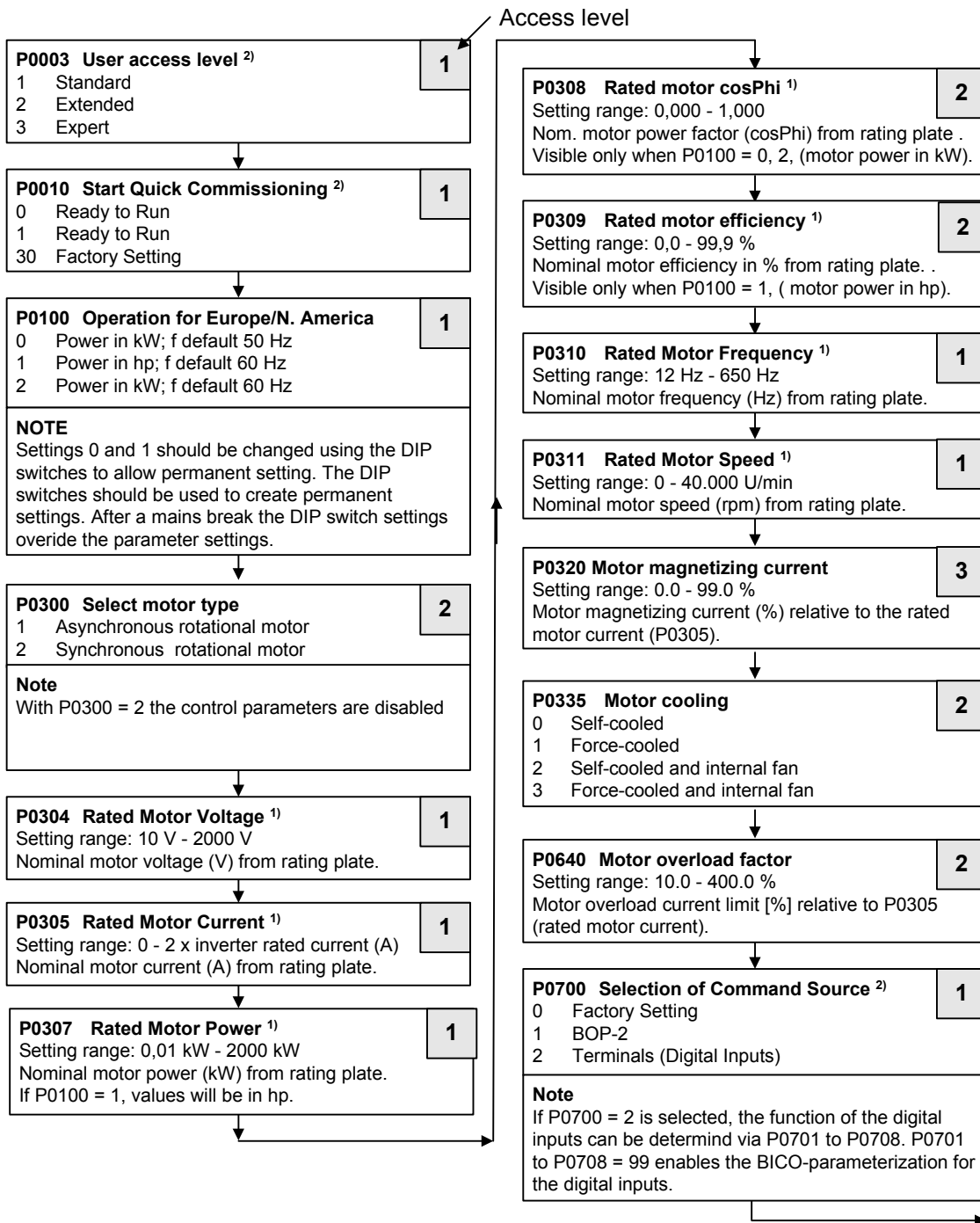

1) Motor-specific parameters – see motor rating plate.  
 2) The parameters offer more setting options than listed here. See Parameter List for further setting options.

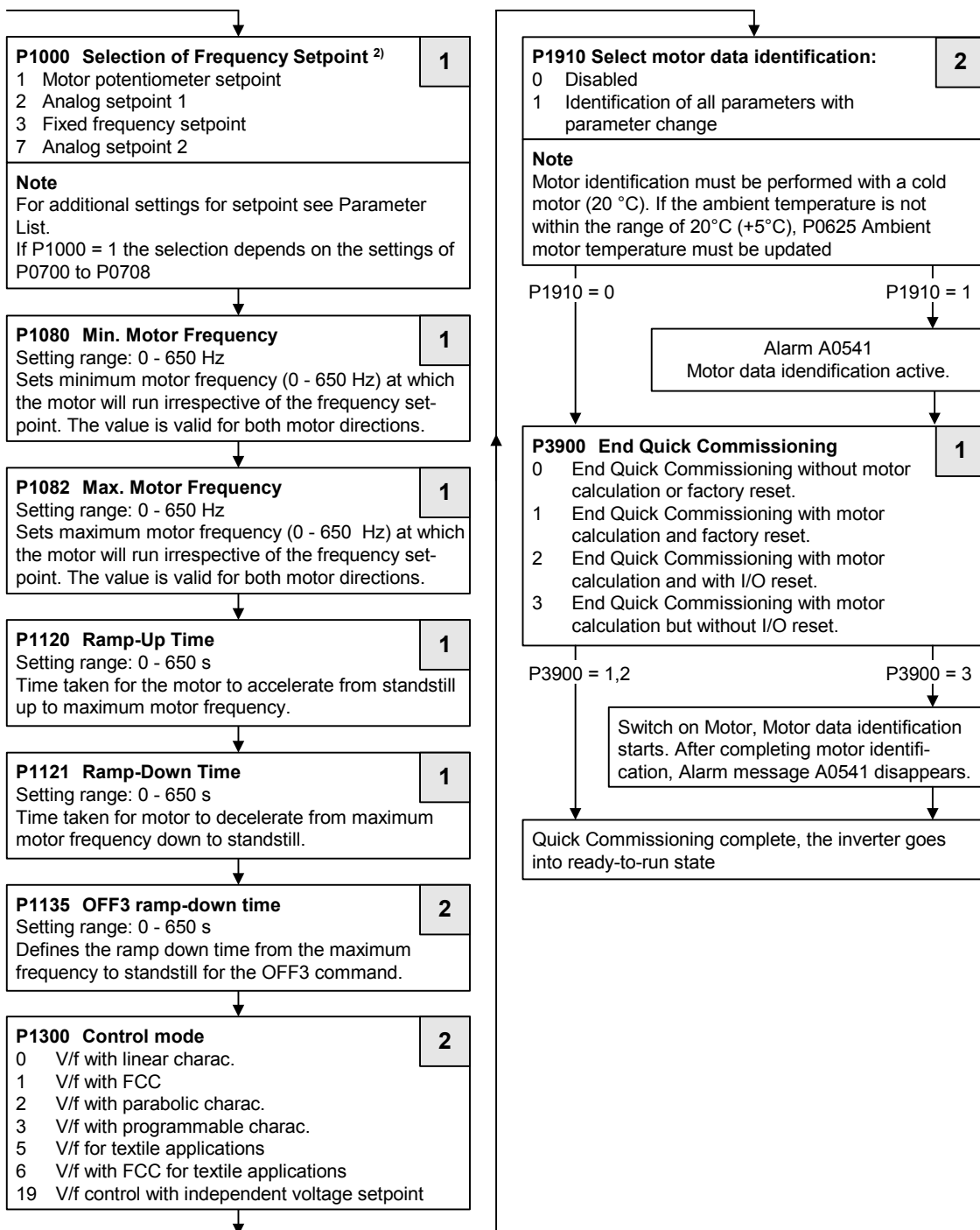

2) The parameters offer more setting options than listed here. See Parameter List for further setting options.

**Motor data for parameterization**

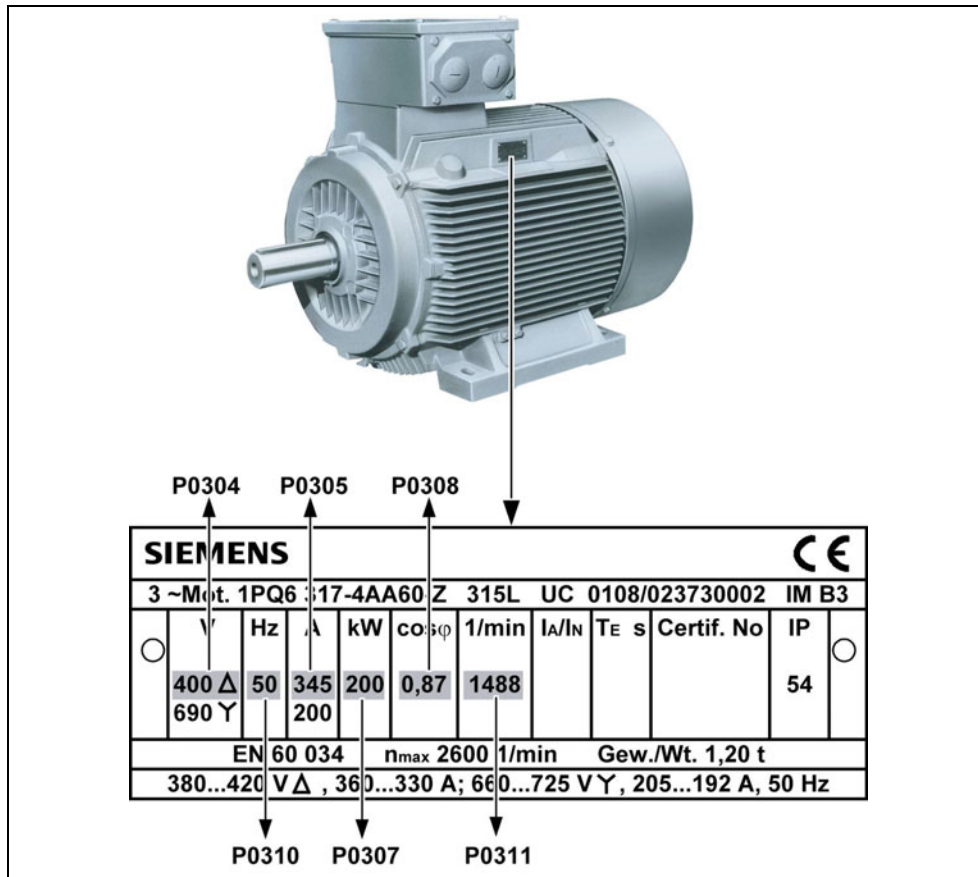

Figure 3-8 Typical Motor Rating Plate Example  
(The details given on the rating plate are only examples)

**NOTICE**

- P0308 & P0309 are only visible if P0003 ≥ 2. Only one of the parameters is shown depending on the settings of P0100.
- P0307 indicates kW or HP depending upon the setting of P0100. For detailed information, please see the Parameter List.
- Changing motor parameters is not possible unless P0010 = 1.
- Ensure that the inverter is configured correctly to the motor.
- Observe the motor's star / delta connection arrangement!

**3.2.4 Reset to Factory default**

To reset all parameters to the factory default settings; the following parameters should be set as follows (BOP-2 or Communication Option needed):

1. Set P0010=30.
2. Set P0970=1.

**NOTE**

The reset process can take up to 3 minutes to complete.

### 3.3 General operation

For a full description of standard and extended parameters, please refer to the Parameter List.

---

#### NOTICE







1. The inverter does not have a main power switch and is live when the mains supply is connected. It waits, with the output disabled, until the RUN button is pressed or for the presence of a digital ON signal at terminal 5 (rotate right).
  2. If a BOP-2 is fitted and the output frequency is selected to be displayed (P0005 = 21) the corresponding setpoint is displayed approximately every 1.0 seconds while the inverter is stopped.
  3. The inverter is programmed at the factory for standard applications on Siemens four-pole standard motors that have the same power rating as the inverters. When using other motors it is necessary to enter the specifications from the motor's rating plate. See Figure 3-8 for details on how to read motor data.
  4. Changing motor parameters is not possible unless P0010 = 1.
  5. Before initiating a run, You must set P0010 back to 0.
- 

#### Basic operation with the BOP-2

---

##### Prerequisites

- P0010 = 0 (in order to initiate the run command correctly).
  - P0700 = 1 (enables the start/stop button on the BOP-2).
  - P1000 = 1 (this enables the motor potentiometer setpoints).
- 

1. Press the green Button  to start the motor.
  2. Press the Button  while the motor is turning. Motor speed increases to 50 Hz.
  3. When the inverter reaches 50 Hz, press the Button . Motor speed and display is decreased.
  4. Press button , to activate manual mode.
  5. Press button , to activate automatic mode.
  6. The red button stops the motor .
- 

#### NOTE

Three Command data sets (CDS) are available. The Hand/Auto-Button on the BOP-2 toggles between CDS 1 and CDS 2. If CDS 3 is selected (via P0811), the Hand/Auto-Button on the BOP-2 is inactive. For further details see the Parameter List.

---



### External motor thermal overload protection

When operated below rated speed, the cooling effect of fans fitted to the motor shaft is reduced. Consequentially, most motors require de-rating for continuous operation at low frequencies. To ensure that the motors are protected against overheating under these conditions, a PTC temperature sensor must be fitted to the motor and connected to the inverter control terminals.

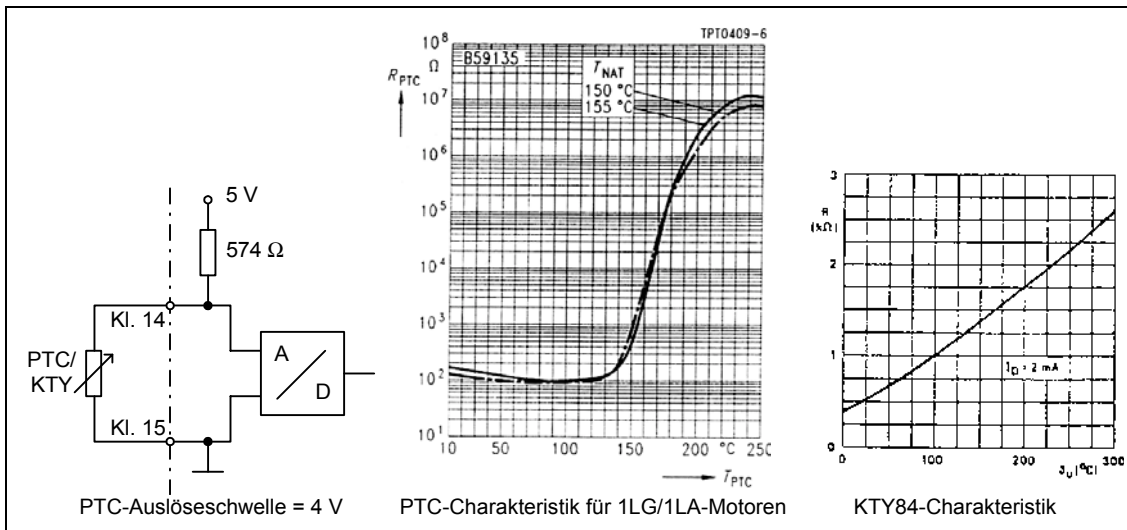

Figure 3-9 Thermal overload protection

#### With PTC sensor (P0601 = 1)

If the PTC in the motor is connected to the MICROMASTER 430 control terminals 14 (PTCA) and 15 (PTCB) and the PTC function enabled by setting P0601 = 1, then the MICROMASTER 430 will operate as normal providing the resistance at the terminals remains below approximately 1500 Ω. If this value is exceeded, the inverter indicates a warning A0511 and then a fault F0011. The actual resistance value at which this occurs will not be less than 1000 Ω, and not more than 2000 Ω.

#### With KTY84 sensor (P0601 = 2)

The KTY84 has to be connected so that the diode is forward biased; that is the anode is connected to terminal 14 (PTCA) and the cathode to terminal 15 (PTCB). If the temperature monitoring function is enabled by setting P0601 = 2, the temperature of the sensor (and therefore the motor windings) is written to parameter r0035. The threshold motor temperature can now be set using parameter P0604 (default setting 130 °C).

#### Connection failure

If the connection to the PTC or KTY84 sensor becomes open circuit or short circuit, a fault will be indicated, and by default the drive will trip.

## 4 MICROMASTER 430 functions

### This chapter contains:

- a description of the different procedures to control the inverter
- a summary of the control types of the inverter.

|     |                                       |    |
|-----|---------------------------------------|----|
| 4.1 | Frequency set point (P1000) .....     | 59 |
| 4.2 | Command sources (P0700).....          | 60 |
| 4.3 | OFF and brake function .....          | 60 |
| 4.4 | Control modes (P1300).....            | 62 |
| 4.5 | MICROMASTER 430 .....                 | 63 |
| 4.6 | Free Function Blocks (P2800 ff) ..... | 67 |
| 4.7 | Faults and Alarms .....               | 67 |

**WARNING**

- ◆ When operating electrical devices, certain parts of these devices are always live.
- ◆ Emergency Off devices in compliance with EN 60204 IEC 204 (VDE 0113) must remain functional in all operating modes of the control device. Resetting the Emergency Off device must not result in uncontrolled or undefined re-starts.
- ◆ In those cases, where short circuits in the control device can result in considerable material damage or even serious bodily harm (i.e. potentially dangerous short circuits), external measures or devices must be taken or fitted to ensure that operation is not dangerous even if a short circuit does occur (e.g. independent limit switches, mechanical locks etc.).
- ◆ MICROMASTER inverters work with high voltages.
- ◆ Certain parameter settings can cause the inverter to start up again automatically after the supply voltage has failed.
- ◆ The motor parameters must be configured exactly to ensure perfect motor overload protection.
- ◆ The device provides an internal motor overload protection system in compliance with UL508C, section 42. See P0610 and P0335, the pre-setting for  $i^2t$  is ON. Motor overload protection can also be secured via an external OTC (factory setting: P0601 "Motor-temperature sensor" deactivated) .
- ◆ The device is suitable for use with circuits which supply a symmetrical current of a maximum of 10.000 A (eff) with a maximum voltage of 460 V, if it is protected by a fuse of Type H or K (see table Table 7-4 onwards).
- ◆ This device must not be used as an „Emergency Off device“ (see EN 60204, 9.2.5.4).

## 4.1 Frequency set point (P1000)

- Pre-setting: terminal 3/4 (AIN+/ AIN -, 0...10 V equivates to 0...50/60 Hz)
- Additional settings: see P1000

**NOTE**

With regard to USS see reference manual, with regard to PROFIBUS see reference manual and PROFIBUS instructions.

## 4.2 Command sources (P0700)

---

### ATTENTION

The **ramp-up /ramp-down times** and **ramp smoothing** also have an effect on the motor's start and stop behaviour. Further details about these functions are to be found in the parameter list for parameters P1120, P1121, P1130 – P1134.

---

### Start motor

- Default: terminal 5 (DIN1, high)
- Additional settings: see P0700 to P0708

### Stop motor

- There are a number of possibilities to stop the motor:
- Default :
  - ◆ OFF1 terminal 5 (DIN1, low)
  - ◆ OFF2 OFF key on BOP-2, press the OFF key once for 2 seconds or press twice
  - ◆ OFF3 not active in factory settings
- Additional settings: see P0700 to P0708

### Reversing the direction of rotation of the motor

This function is inhibited in the factory settings. To release it, you must set P1110 = 0.

- Default: terminal 6 (DIN2, high)
- Additional settings: see P0700 to P0708

## 4.3 OFF and brake function

### 4.3.1 OFF1

This command (which is triggered by the cancellation of the ON order) causes the inverter to come to a standstill within the selected ramp-down time.

For parameters to change ramp-down time: see P1121

---

### ATTENTION

- The ON and the subsequent OFF command must come from the same source.
  - If the ON / OFF1 command is set for more than one digital input, only the digital input set last will be valid, e.g. DIN3 is active.
  - OFF1 can be combined with DC braking or compound braking.
-

### 4.3.2 OFF2

This command causes the motor to run down freely to a standstill (impulses deactivated).

---

#### ATTENTION

The OFF command can have one or more sources. The default causes the OFF2 command to be set to BOP-2. This source continues to exist even if other sources are defined by **one** of the parameters P0700 to P0708.

---

### 4.3.3 OFF3

The OFF3 command causes the motor to be slowed down quickly.

The binary input must be closed to start the motor if the command OFF3 has been set. If OFF3 is closed, the motor can be started and stopped by commands OFF1 or OFF2.

If OFF3 is open, the motor cannot be started..

➤ ramp-down time: see P1135

---

#### ATTENTION:

OFF3 can be combined with DC braking, compound braking or dynamic braking.

---

### 4.3.4 DC braking

DC braking is possible together with OFF1 and OFF3. Direct current is input which brakes the motor quickly and holds the shaft until the end of the braking period.

- Activate DC braking: see P0701 to P0708
- Set DC brake period: see P1233
- Set DC braking current: see P1232
- Set DC braking start frequency: see P1234

---

#### ATTENTION

If no digital input is set to DC braking, DC braking is active for  $P1233 \neq 0$  after every OFF1 command with the period set in P1233.

---

### 4.3.5 Compound braking

Compound braking is possible with OFF1 and OFF3. In the case of compound braking, a DC component is superimposed on the alternating current.

Set braking current : see P1236

## 4.4 Control modes (P1300)

MICROMASTER 430 has a number of different control modes based on U/f-control. The individual modes have been listed below, additional settings are listed in the parameter list and the function plans contained therein.

- **Linear U/f control** **P1300 = 0**  
Can be used for variable and constant torque applications e.g. transport systems and positive displacement pumps.
- **Linear U/f control with flux current control (FCC)** **P1300 = 1**  
This type of control can be used to improve the performance and dynamic behaviour of the motor.
- **Parabolic U/f control** **P1300 = 2**  
This type of control can be used for variable torque loads e.g. fan and pumps.
- **Multiple point U/f control** **P1300 = 3**  
Please refer to the MICROMASTER 430 parameter list for more information on this operating mode.
- **U/f control for textile applications** **P1300 = 5**  
There is no slip compensation gain or resonance dampening. The I<sub>max</sub> controller refers to voltage instead of frequency.
- **U/f control with FCC for textile applications** **P1300 = 6**  
A combination of P1300 = 1 and P1300 = 5.
- **U/f control with independent voltage set point** **P1300 = 19**  
Using the P1330, the voltage set point can be given independently from the starting frequency of the ramp function generator (HLG).

## 4.5 MICROMASTER 430 operating modes

### 4.5.1 Bypass Mode

Setting up an inverter bypass circuit

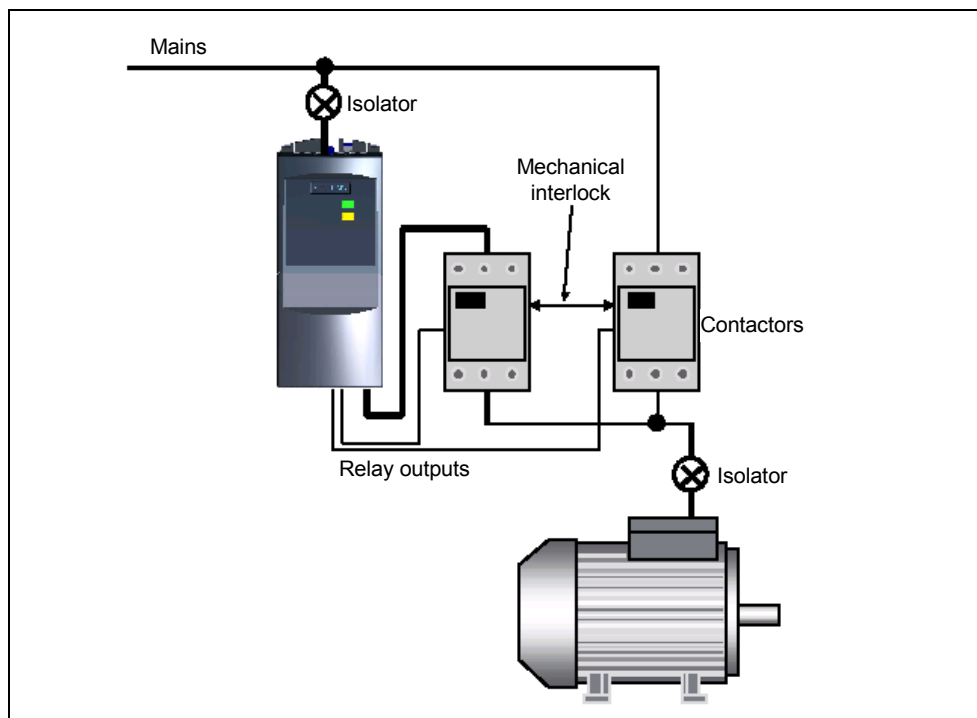

Figure 4-1 Bypass circuit

#### Function

Control of two locked contactors via relay outputs of MICROMASTER 430. This circuit makes it possible to operate the motor via the inverter or directly via the mains. The inverter is responsible for switching.

Switching is possible by the following means:

- error message from the inverter
- digital input
- inverter frequency

For further settings please refer to parameters list P1260 and following.

### 4.5.2 Belt Failure Detection

Recognizes mechanical faults in drive section e.g. torn V-belt, pumps which have run dry etc.

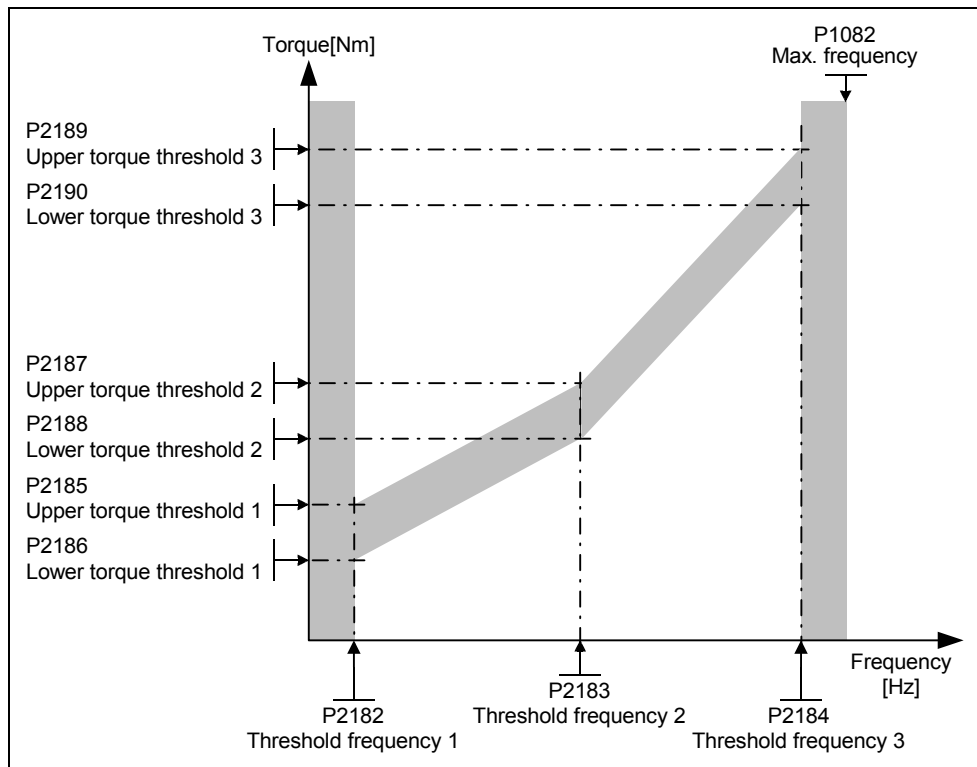

Figure 4-2 Belt Failure Detection

#### Function

A torque band is monitored. This enables underload and overload conditions to be recognized (e.g. ventilator not running correctly)

Comparison between current speed / torque curve with programmed envelope curve. The upper and lower frequency curve can be specified via three supporting points each. In addition a dead time until the function is triggered can be defined. This avoids accidental triggering due to transient events.

For additional settings please refer to parameter list P2181 and following.



### 4.5.3 Motor Staging

Controlling additional drives via output relay

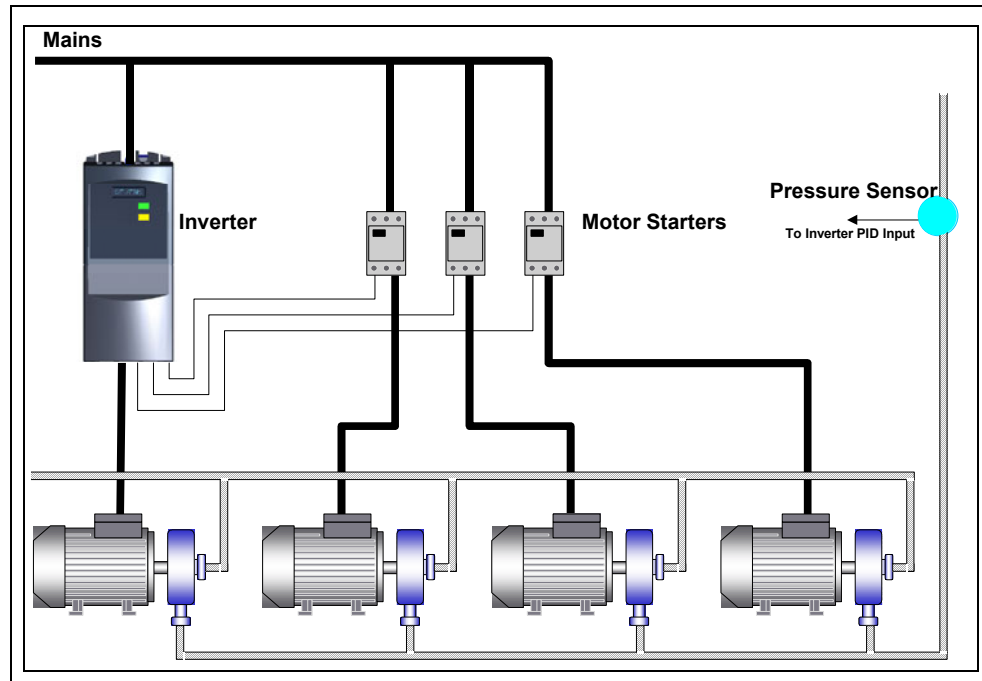

Figure 4-3 Motor Staging

#### Function

Enables up to three additional motors to be controlled based on PID control

The entire system is made up of a pump which is controlled by the inverter with up to an additional 3 pumps which can be added to the system via contactors or motor starters. The motor starter is controlled via the output relay in the inverter. Figure 4-3 shows a typical pump system.

This function can also be used accordingly for ventilators and ventilation shafts.

For additional settings please refer to parameter list P2370 and following.

### 4.5.4 Energy Saving Mode

Energy saving mode to switch off the motor when it is in idle mode

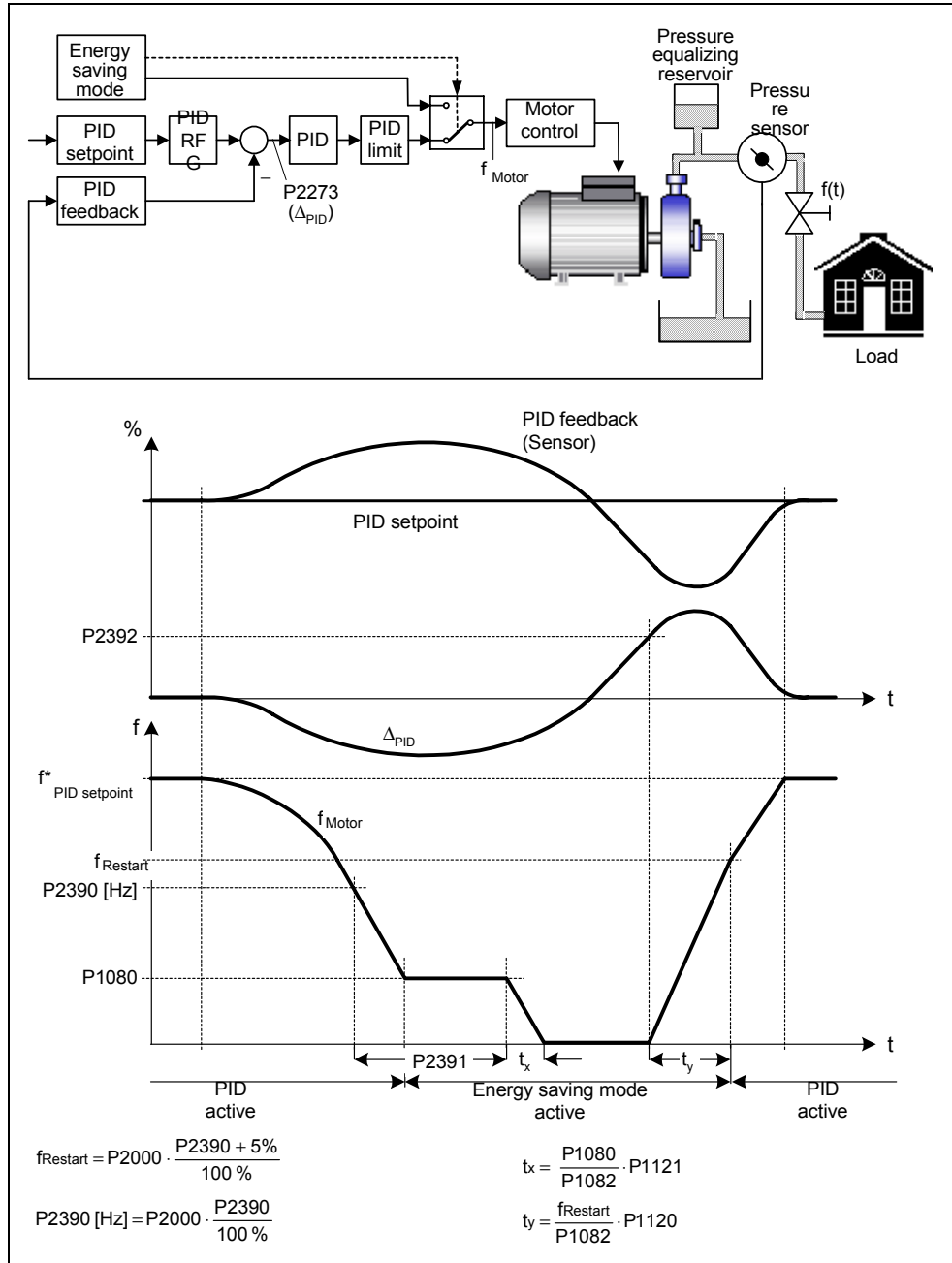

Figure 4-4 Energy Saving Mode

## Function

Energy saving mode extends the function of the PID controller.

This enables the motor to be operated for a defined period of time with a minimum frequency and to switch it off afterwards. If the re-start frequency is reached, the motor is automatically re-started again. Energy saving mode is independent of the Motor Staging Function. It is possible to combine Motor Staging and Energy Saving Mode.

For additional settings please refer to the parameter list P2390 and following.

## 4.6 Free Function Blocks (P2800 ff)

Using free function blocks, internal signals (Digital inputs, set points, actual values, ...) can be interlinked, to enable application specific control.

## 4.7 Faults and Alarms

### SDP

With the SDP Faults and Alarms conditions are displayed via the two LEDs on the SDP. For further information see Section 6.1 on page 90.

The operation status of the inverter is indicated by the two LEDs as follows:

- Green and yellow = Ready to run
- Green only = Inverter running

### BOP-2

If a BOP-2 has been fitted to the inverter, details of any fault condition will be displayed by the operator panel. For detailed information of fault conditions and alarms, See Section 6 parameter list.



## 5 System parameters

**This Chapter contains:**

- An overview of the parameter structure of the MICROMASTER 430
- A parameter list in short form

|     |   |    |
|-----|---|----|
| 5.1 | Introduction to MICROMASTER system parameters ..... | 70 |
| 5.2 | Parameter overview .....                            | 71 |
| 5.3 | Parameter list (short form) .....                   | 72 |
| 5.4 | Command and Drive Datasets - Overview .....         | 85 |

## 5.1 Introduction to MICROMASTER system parameters

**The parameters can only be changed by using the BOP-2 or the Serial Interface.**

Parameters can be changed and set using the BOP-2 to adjust the desired properties of the inverter, such as ramp times, minimum and maximum frequencies etc. The parameter numbers selected and the setting of the parameter values are indicated on the optional five-digit LCD display.

- rxxxx indicates a display parameter, Pxxxx a setting parameter.
- P0010 initiates “quick commissioning”.
- The inverter will not run unless P0010 is set to 0 after it has been accessed. This function is automatically perform if P3900 > 0.
- P0004 acts as a filter, allowing access to parameters according to their functionality.
- If an attempt is made to change a parameter that cannot be changed in this status, for example, cannot be changed whilst running or can only be changed in quick commissioning, then **-----** will be displayed.
- **Busy Message**  
In some cases - when changing parameter values - the display on the BOP-2 shows **buSY** for maximum of five seconds. This means the inverter is busy with tasks of higher priority.

---

### ATTENTION

MICROMASTER 430 can only be operated using a BOP-2. If the BOP or AOP is used, the following is displayed **-----**.

---

### 5.1.1 Access Levels

There are three access levels available to the user; Standard, Extended and Expert. The level of access is set by parameter P0003. For most applications, Standard (P0003 = 1) or Extended parameters (P0003 = 2) are sufficient.

---

### CAUTION

Some of level 4 parameters are for internal system settings only and should not be modified.

Level 4 parameters should only be modified by authorized personnel.

---

The number of parameters that appear within each functional group depends on the access level set in parameter P0003. For further details regarding parameters, see the Parameter List on the Documentation CD-ROM.

## 5.2 Parameter overview

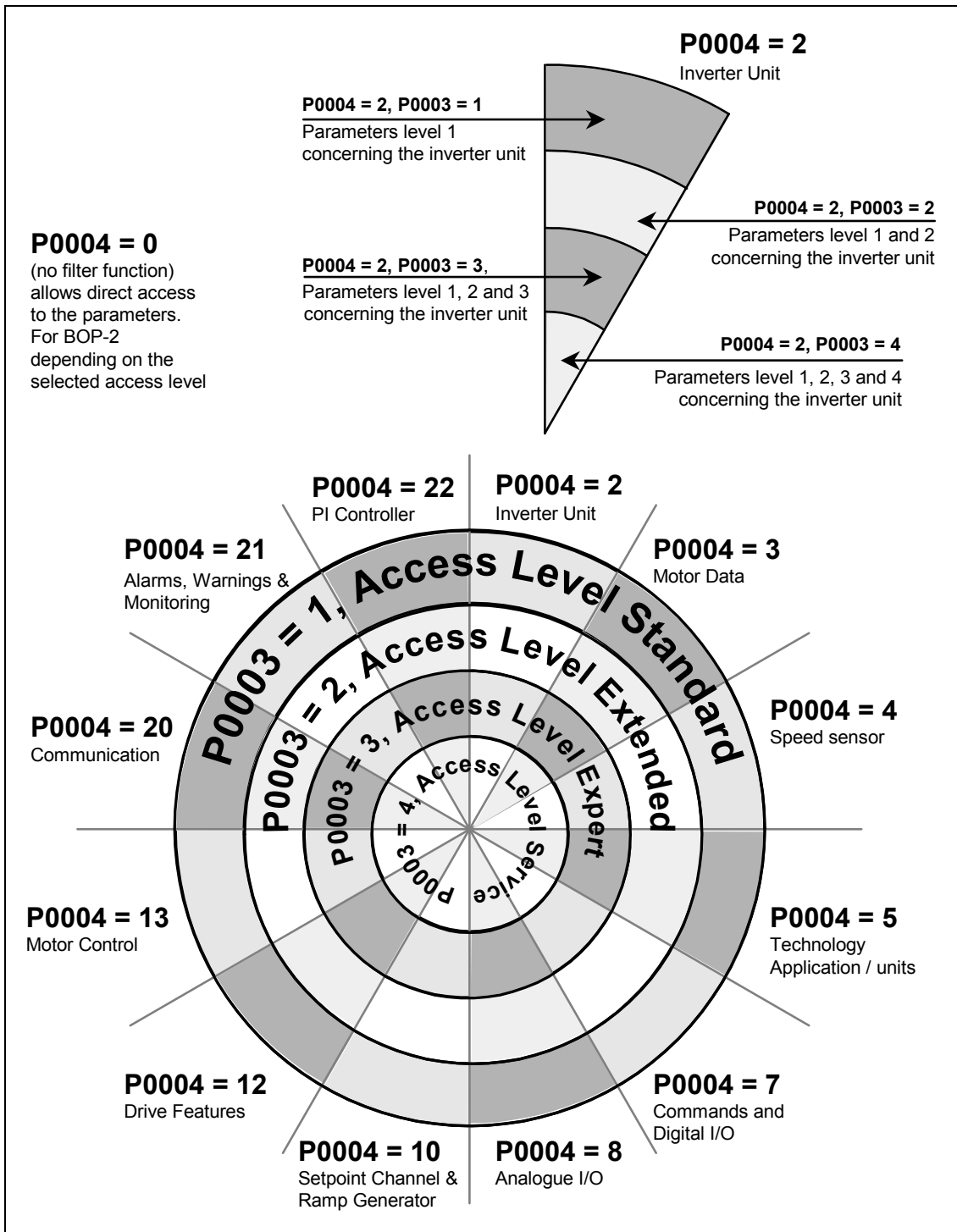

Figure 5-1 Parameter Overview

### 5.3 Parameter list (short form)

Explanatory information on following table:

- Default: Factory setting
- Level: Access level
- DS Inverter status (Drive State), indicates the inverter state in which a parameter can be modified (see P0010).
  - ◆ C Commissioning
  - ◆ U Run
  - ◆ T Ready to run
- QC Quick Commissioning
  - ◆ Q Parameter can be modified in the Quick Commissioning state.
  - ◆ N Parameter cannot be modified in the Quick Commissioning state.

#### Always

| ParNo | ParText                 | Default | Level | DS  | QC |
|-------|-------------------------|---------|-------|-----|----|
| r0000 | Drive display           | -       | 1     | -   | -  |
| P0003 | User access level       | 1       | 1     | CUT | N  |
| P0004 | Parameter filter        | 0       | 1     | CUT | N  |
| P0010 | Commissioning parameter | 0       | 1     | CT  | N  |

#### Inverter Unit (P0004 = 2)

| ParNo | ParText                    | Default | Level | DS | QC |
|-------|----------------------------|---------|-------|----|----|
| P0100 | Europe / North America     | 0       | 1     | C  | Q  |
| P3900 | End of quick commissioning | 0       | 1     | C  | Q  |

#### Parameter Reset

| ParNo | ParText       | Default | Level | DS | QC |
|-------|---------------|---------|-------|----|----|
| P0970 | Factory reset | 0       | 1     | C  | N  |

#### Inverter Unit (P0004 = 2)

| ParNo    | ParText                          | Default | Level | DS | QC |
|----------|----------------------------------|---------|-------|----|----|
| r0018    | Firmware version                 | -       | 3     | -  | -  |
| r0026[1] | CO: Act. DC-link voltage         | -       | 3     | -  | -  |
| r0037[2] | CO: Inverter temperature [°C]    | -       | 3     | -  | -  |
| r0039    | CO: Energy consumpt. meter [kWh] | -       | 3     | -  | -  |
| P0040    | Reset energy consumption meter   | 0       | 3     | CT | N  |
| r0200    | Act. power stack code number     | -       | 3     | -  | -  |
| P0201    | Power stack code number          | 0       | 3     | C  | N  |
| r0203    | Act. inverter type               | -       | 3     | -  | -  |
| r0204    | Power stack features             | -       | 3     | -  | -  |
| r0206    | Rated inverter power [kW] / [hp] | -       | 3     | -  | -  |
| r0207    | Rated inverter current           | -       | 3     | -  | -  |
| r0208    | Rated inverter voltage           | -       | 3     | -  | -  |
| r0209    | Maximum inverter current         | -       | 3     | -  | -  |



| ParNo    | ParText                       | Default | Level | DS  | QC |
|----------|-------------------------------|---------|-------|-----|----|
| P0210    | Supply voltage                | 230     | 3     | CT  | N  |
| r0231[2] | Max. cable length             | -       | 3     | -   | -  |
| P0290    | Inverter overload reaction    | 2       | 3     | CT  | N  |
| P0292    | Inverter overload warning     | 15      | 3     | CUT | N  |
| P0291[3] | Inverter protection           | 1       | 3     | CT  | N  |
| P1800    | Pulse frequency               | 4       | 2     | CUT | N  |
| r1801    | CO: Act. pulse frequency      | -       | 3     | -   | -  |
| P1802    | Modulator mode                | 0       | 3     | CUT | N  |
| P1820[3] | Reverse output phase sequence | 0       | 3     | CT  | N  |
| P1911    | No. of phase to be identified | 3       | 3     | CT  | N  |
| r1925    | Identified on-state voltage   | -       | 3     | -   | -  |
| r1926    | Ident. gating unit dead time  | -       | 3     | -   | -  |

### Motor Data (P0004 = 3)

| ParNo    | ParText                          | Default | Level | DS  | QC |
|----------|----------------------------------|---------|-------|-----|----|
| r0035[3] | CO: Act. motor temperature       | -       | 3     | -   | -  |
| P0304[3] | Rated motor voltage              | 230     | 1     | C   | Q  |
| P0305[3] | Rated motor current              | 3.25    | 1     | C   | Q  |
| P0307[3] | Rated motor power                | 0.75    | 1     | C   | Q  |
| P0308[3] | Rated motor cosPhi               | 0.000   | 3     | C   | Q  |
| P0309[3] | Rated motor efficiency           | 0.0     | 3     | C   | Q  |
| P0310[3] | Rated motor frequency            | 50.00   | 1     | C   | Q  |
| P0311[3] | Rated motor speed                | 0       | 1     | C   | Q  |
| r0313[3] | Motor pole pairs                 | -       | 3     | -   | -  |
| P0320[3] | Motor magnetizing current        | 0.0     | 3     | CT  | Q  |
| r0330[3] | Rated motor slip                 | -       | 3     | -   | -  |
| r0331[3] | Rated magnetization current      | -       | 3     | -   | -  |
| r0332[3] | Rated power factor               | -       | 3     | -   | -  |
| P0335[3] | Motor cooling                    | 0       | 3     | CT  | Q  |
| P0340[3] | Calculation of motor parameters  | 0       | 3     | CT  | N  |
| P0344[3] | Motor weight                     | 9.4     | 3     | CUT | N  |
| P0346[3] | Magnetization time               | 1.000   | 3     | CUT | N  |
| P0347[3] | Demagnetization time             | 1.000   | 3     | CUT | N  |
| P0350[3] | Stator resistance (line-to-line) | 4.0     | 3     | CUT | N  |
| P0352[3] | Cable resistance                 | 0.0     | 3     | CUT | N  |
| r0384[3] | Rotor time constant              | -       | 3     | -   | -  |
| r0395    | CO: Total stator resistance [%]  | -       | 3     | -   | -  |
| r0396    | CO: Act. rotor resistance        | -       | 3     | -   | -  |
| P0601[3] | Motor temperature sensor         | 0       | 3     | CUT | N  |
| P0604[3] | Threshold motor temperature      | 130.0   | 2     | CUT | N  |
| P0610[3] | Motor I2t temperature reaction   | 2       | 3     | CT  | N  |
| P0625[3] | Ambient motor temperature        | 20.0    | 3     | CUT | N  |
| P0640[3] | Motor overload factor [%]        | 110.0   | 3     | CUT | Q  |
| P1910    | Select motor data identification | 0       | 3     | CT  | Q  |
| r1912[3] | Identified stator resistance     | -       | 3     | -   | -  |

**Encoder (P0004 = 4)**

| ParNo    | ParText                       | Default | Level | DS  | QC |
|----------|-------------------------------|---------|-------|-----|----|
| P0400[3] | Select encoder type           | 0       | 3     | CT  | N  |
| P0408[3] | Encoder pulses per revolution | 1024    | 3     | CT  | N  |
| P0492[3] | Allowed speed difference      | 10.00   | 3     | CT  | N  |
| P0494[3] | Delay speed loss reaction     | 10      | 3     | CUT | N  |

**Technological Functions (P0004 = 5)**

| ParNo    | ParText                   | Default | Level | DS | QC |
|----------|---------------------------|---------|-------|----|----|
| P0500[3] | Technological application | 0       | 3     | CT | Q  |

**Commands and Digital I/O (P0004 = 7)**

| ParNo    | ParText                          | Default | Level | DS  | QC |
|----------|----------------------------------|---------|-------|-----|----|
| r0002    | Drive state                      | -       | 3     | -   | -  |
| r0019    | CO/BO: BOP control word          | -       | 3     | -   | -  |
| r0050    | CO: Active command data set      | -       | 2     | -   | -  |
| r0052    | CO/BO: Act. status word 1        | -       | 3     | -   | -  |
| r0051[2] | CO: Active drive data set (DDS)  | -       | 2     | -   | -  |
| r0053    | CO/BO: Act. status word 2        | -       | 3     | -   | -  |
| r0054    | CO/BO: Act. control word 1       | -       | 3     | -   | -  |
| r0055    | CO/BO: Add. act. control word    | -       | 3     | -   | -  |
| r0403    | CO/BO: Encoder status word       | -       | 3     | -   | -  |
| P0700[3] | Selection of command source      | 2       | 1     | CT  | Q  |
| P0701[3] | Function of digital input 1      | 1       | 2     | CT  | N  |
| P0702[3] | Function of digital input 2      | 12      | 2     | CT  | N  |
| P0703[3] | Function of digital input 3      | 9       | 2     | CT  | N  |
| P0704[3] | Function of digital input 4      | 15      | 2     | CT  | N  |
| P0705[3] | Function of digital input 5      | 15      | 2     | CT  | N  |
| P0706[3] | Function of digital input 6      | 15      | 2     | CT  | N  |
| P0707[3] | Function of digital input 7      | 0       | 3     | CT  | N  |
| P0708[3] | Function of digital input 8      | 0       | 3     | CT  | N  |
| P0718    | CO/BO: Hand / Auto               | 0       | 3     | CUT | N  |
| r0720    | Number of digital inputs         | -       | 3     | -   | -  |
| P0719[3] | Selection of cmd. & freq. setp.  | 0       | 3     | CT  | N  |
| r0722    | CO/BO: Binary input values       | -       | 3     | -   | -  |
| P0724    | Debounce time for digital inputs | 3       | 3     | CT  | N  |
| P0725    | PNP / NPN digital inputs         | 1       | 3     | CT  | N  |
| r0730    | Number of digital outputs        | -       | 3     | -   | -  |
| P0731[3] | BI: Function of digital output 1 | 52:3    | 2     | CUT | N  |
| P0732[3] | BI: Function of digital output 2 | 52:7    | 2     | CUT | N  |
| P0733[3] | BI: Function of digital output 3 | 0:0     | 2     | CUT | N  |
| r0747    | CO/BO: State of digital outputs  | -       | 3     | -   | -  |
| P0748    | Invert digital outputs           | 0       | 3     | CUT | N  |
| P0800[3] | BI: Download parameter set 0     | 0:0     | 3     | CT  | N  |
| P0801[3] | BI: Download parameter set 1     | 0:0     | 3     | CT  | N  |
| P0810    | BI: CDS bit 0 (Local / Remote)   | 718:0   | 3     | CUT | N  |

| ParNo    | ParText                          | Default | Level | DS  | QC |
|----------|----------------------------------|---------|-------|-----|----|
| P0811    | Bl: CDS bit 1                    | 0:0     | 2     | CUT | N  |
| P0809[3] | Copy command data set (CDS)      | 0       | 3     | CT  | N  |
| P0820    | Bl: DDS bit 0                    | 0:0     | 3     | CT  | N  |
| P0821    | Bl: DDS bit 1                    | 0:0     | 3     | CT  | N  |
| P0819[3] | Copy drive data set (DDS)        | 0       | 2     | CT  | N  |
| P0840[3] | Bl: ON/OFF1                      | 722:0   | 3     | CT  | N  |
| P0842[3] | Bl: ON reverse/OFF1              | 0:0     | 3     | CT  | N  |
| P0844[3] | Bl: 1. OFF2                      | 1:0     | 3     | CT  | N  |
| P0845[3] | Bl: 2. OFF2                      | 19:1    | 3     | CT  | N  |
| P0848[3] | Bl: 1. OFF3                      | 1:0     | 3     | CT  | N  |
| P0849[3] | Bl: 2. OFF3                      | 1:0     | 3     | CT  | N  |
| P0852[3] | Bl: Pulse enable                 | 1:0     | 3     | CT  | N  |
| P1020[3] | Bl: Fixed freq. selection Bit 0  | 0:0     | 3     | CT  | N  |
| P1021[3] | Bl: Fixed freq. selection Bit 1  | 0:0     | 3     | CT  | N  |
| P1022[3] | Bl: Fixed freq. selection Bit 2  | 0:0     | 3     | CT  | N  |
| P1023[3] | Bl: Fixed freq. selection Bit 3  | 722:3   | 3     | CT  | N  |
| P1026[3] | Bl: Fixed freq. selection Bit 4  | 722:4   | 3     | CT  | N  |
| P1028[3] | Bl: Fixed freq. selection Bit 5  | 722:5   | 3     | CT  | N  |
| P1035[3] | Bl: Enable MOP (UP-command)      | 19:13   | 3     | CT  | N  |
| P1036[3] | Bl: Enable MOP (DOWN-command)    | 19:14   | 3     | CT  | N  |
| P1074[3] | Bl: Disable additional setpoint  | 0:0     | 3     | CUT | N  |
| P1110[3] | Bl: Inhibit neg. freq. setpoint  | 1:0     | 3     | CT  | N  |
| P1113[3] | Bl: Reverse                      | 722:1   | 3     | CT  | N  |
| P1140[3] | Bl: RFG enable                   | 1:0     | 3     | CT  | N  |
| P1141[3] | Bl: RFG start                    | 1:0     | 3     | CT  | N  |
| P1142[3] | Bl: RFG enable setpoint          | 1:0     | 3     | CT  | N  |
| P1230[3] | Bl: Enable DC braking            | 0:0     | 3     | CUT | N  |
| P1270[3] | Bl: Enable essential service     | 0:0     | 3     | CUT | N  |
| P2103[3] | Bl: 1. Faults acknowledgement    | 722:2   | 3     | CT  | N  |
| P2104[3] | Bl: 2. Faults acknowledgement    | 0:0     | 3     | CT  | N  |
| P2106[3] | Bl: External fault               | 1:0     | 3     | CT  | N  |
| P2220[3] | Bl: Fixed PID setp. select Bit 0 | 0:0     | 3     | CT  | N  |
| P2221[3] | Bl: Fixed PID setp. select Bit 1 | 0:0     | 3     | CT  | N  |
| P2222[3] | Bl: Fixed PID setp. select Bit 2 | 0:0     | 3     | CT  | N  |
| P2223[3] | Bl: Fixed PID setp. select Bit 3 | 722:3   | 3     | CT  | N  |
| P2226[3] | Bl: Fixed PID setp. select Bit 4 | 722:4   | 3     | CT  | N  |
| P2228[3] | Bl: Fixed PID setp. select Bit 5 | 722:5   | 3     | CT  | N  |
| P2235[3] | Bl: Enable PID-MOP (UP-cmd)      | 19:13   | 3     | CT  | N  |
| P2236[3] | Bl: Enable PID-MOP (DOWN-cmd)    | 19:14   | 3     | CT  | N  |

### Analogue I/O (P0004 = 8)

| ParNo    | ParText                       | Default | Level | DS  | QC |
|----------|-------------------------------|---------|-------|-----|----|
| P0295    | Inverter fan off delay time   | 0       | 3     | CUT | N  |
| r0750    | Number of ADCs                | -       | 3     | -   | -  |
| r0752[2] | Act. input of ADC [V] or [mA] | -       | 2     | -   | -  |

| ParNo    | ParText                          | Default | Level | DS  | QC |
|----------|----------------------------------|---------|-------|-----|----|
| P0753[2] | Smooth time ADC                  | 3       | 3     | CUT | N  |
| r0754[2] | Act. ADC value after scaling [%] | -       | 2     | -   | -  |
| r0755[2] | CO: Act. ADC after scal. [4000h] | -       | 3     | -   | -  |
| P0756[2] | Type of ADC                      | 0       | 2     | CT  | N  |
| P0757[2] | Value x1 of ADC scaling [V / mA] | 0       | 2     | CUT | N  |
| P0758[2] | Value y1 of ADC scaling          | 0.0     | 2     | CUT | N  |
| P0759[2] | Value x2 of ADC scaling [V / mA] | 10      | 2     | CUT | N  |
| P0760[2] | Value y2 of ADC scaling          | 100.0   | 2     | CUT | N  |
| P0761[2] | Width of ADC deadband [V / mA]   | 0       | 3     | UT  | N  |
| P0762[2] | Delay for loss of signal action  | 10      | 3     | CUT | N  |
| r0770    | Number of DACs                   | -       | 3     | -   | -  |
| P0771[2] | CI: DAC                          | 21:0    | 2     | CUT | N  |
| P0773[2] | Smooth time DAC                  | 2       | 3     | CUT | N  |
| r0774[2] | Act. DAC value [V] or [mA]       | -       | 3     | -   | -  |
| P0776[2] | Type of DAC                      | 0       | 2     | CT  | N  |
| P0777[2] | Value x1 of DAC scaling          | 0.0     | 2     | CUT | N  |
| P0778[2] | Value y1 of DAC scaling          | 0       | 2     | CUT | N  |
| P0779[2] | Value x2 of DAC scaling          | 100.0   | 2     | CUT | N  |
| P0780[2] | Value y2 of DAC scaling          | 20      | 2     | CUT | N  |
| P0781[2] | Width of DAC deadband            | 0       | 3     | CUT | N  |

### Setpoint Channel and Ramp Generator (P0004 = 10)

| ParNo    | ParText                         | Default | Level | DS  | QC |
|----------|---------------------------------|---------|-------|-----|----|
| P1000[3] | Selection of frequency setpoint | 2       | 1     | CT  | Q  |
| P1001[3] | Fixed frequency 1               | 0.00    | 3     | CUT | N  |
| P1002[3] | Fixed frequency 2               | 5.00    | 3     | CUT | N  |
| P1003[3] | Fixed frequency 3               | 10.00   | 3     | CUT | N  |
| P1004[3] | Fixed frequency 4               | 15.00   | 3     | CUT | N  |
| P1005[3] | Fixed frequency 5               | 20.00   | 3     | CUT | N  |
| P1006[3] | Fixed frequency 6               | 25.00   | 3     | CUT | N  |
| P1007[3] | Fixed frequency 7               | 30.00   | 3     | CUT | N  |
| P1008[3] | Fixed frequency 8               | 35.00   | 3     | CUT | N  |
| P1009[3] | Fixed frequency 9               | 40.00   | 3     | CUT | N  |
| P1010[3] | Fixed frequency 10              | 45.00   | 3     | CUT | N  |
| P1011[3] | Fixed frequency 11              | 50.00   | 3     | CUT | N  |
| P1012[3] | Fixed frequency 12              | 55.00   | 3     | CUT | N  |
| P1013[3] | Fixed frequency 13              | 60.00   | 3     | CUT | N  |
| P1016    | Fixed frequency mode - Bit 0    | 1       | 3     | CT  | N  |
| P1014[3] | Fixed frequency 14              | 65.00   | 3     | CUT | N  |
| P1017    | Fixed frequency mode - Bit 1    | 1       | 3     | CT  | N  |
| P1015[3] | Fixed frequency 15              | 65.00   | 3     | CUT | N  |
| P1018    | Fixed frequency mode - Bit 2    | 1       | 3     | CT  | N  |
| P1019    | Fixed frequency mode - Bit 3    | 1       | 3     | CT  | N  |
| r1024    | CO: Act. fixed frequency        | -       | 3     | -   | -  |
| P1025    | Fixed frequency mode - Bit 4    | 1       | 3     | CT  | N  |

| ParNo    | ParText                          | Default | Level | DS  | QC |
|----------|----------------------------------|---------|-------|-----|----|
| P1027    | Fixed frequency mode - Bit 5     | 1       | 3     | CT  | N  |
| P1032    | Inhibit reverse direction of MOP | 1       | 3     | CT  | N  |
| P1031[3] | Setpoint memory of the MOP       | 0       | 3     | CUT | N  |
| P1040[3] | Setpoint of the MOP              | 5.00    | 2     | CUT | N  |
| r1050    | CO: Act. Output freq. of the MOP | -       | 3     | -   | -  |
| P1070[3] | CI: Main setpoint                | 755:0   | 3     | CT  | N  |
| P1071[3] | CI: Main setpoint scaling        | 1:0     | 3     | CT  | N  |
| P1075[3] | CI: Additional setpoint          | 0:0     | 3     | CT  | N  |
| r1078    | CO: Total frequency setpoint     | -       | 3     | -   | -  |
| P1076[3] | CI: Additional setpoint scaling  | 1:0     | 3     | CT  | N  |
| P1080[3] | Min. frequency                   | 0.00    | 1     | CUT | Q  |
| P1082[3] | Max. frequency                   | 50.00   | 1     | CT  | Q  |
| P1091[3] | Skip frequency 1                 | 0.00    | 3     | CUT | N  |
| P1092[3] | Skip frequency 2                 | 0.00    | 3     | CUT | N  |
| P1093[3] | Skip frequency 3                 | 0.00    | 3     | CUT | N  |
| P1094[3] | Skip frequency 4                 | 0.00    | 3     | CUT | N  |
| P1101[3] | Skip frequency bandwidth         | 2.00    | 3     | CUT | N  |
| r1114    | CO: Freq. setp. after dir. ctrl. | -       | 3     | -   | -  |
| r1119    | CO: Freq. setpoint before RFG    | -       | 3     | -   | -  |
| P1120[3] | Ramp-up time                     | 10.00   | 1     | CUT | Q  |
| P1121[3] | Ramp-down time                   | 30.00   | 1     | CUT | Q  |
| P1130[3] | Ramp-up initial rounding time    | 0.00    | 2     | CUT | N  |
| P1131[3] | Ramp-up final rounding time      | 0.00    | 2     | CUT | N  |
| P1132[3] | Ramp-down initial rounding time  | 0.00    | 2     | CUT | N  |
| P1133[3] | Ramp-down final rounding time    | 0.00    | 2     | CUT | N  |
| P1134[3] | Rounding type                    | 0       | 2     | CUT | N  |
| P1135[3] | OFF3 ramp-down time              | 5.00    | 2     | CUT | Q  |
| r1170    | CO: Frequency setpoint after RFG | -       | 3     | -   | -  |

### Drive Features (P0004 = 12)

| ParNo     | ParText                         | Default | Level | DS  | QC |
|-----------|---------------------------------|---------|-------|-----|----|
| P0005[3]  | Display selection               | 21      | 2     | CUT | N  |
| P0006     | Display mode                    | 2       | 3     | CUT | N  |
| P0007     | Backlight delay time            | 0       | 3     | CUT | N  |
| P0011     | Lock for user defined parameter | 0       | 3     | CUT | N  |
| P0012     | Key for user defined parameter  | 0       | 3     | CUT | N  |
| P0013[20] | User defined parameter          | 0       | 3     | CUT | N  |
| P1200     | Flying start                    | 0       | 3     | CUT | N  |
| P1202[3]  | Motor-current: Flying start     | 100     | 3     | CUT | N  |
| P1203[3]  | Search rate: Flying start       | 100     | 3     | CUT | N  |
| P1210     | Automatic restart               | 1       | 3     | CUT | N  |
| P1211     | Number of restart attempts      | 3       | 3     | CUT | N  |
| P1212     | Time to first restart           | 30      | 3     | CUT | N  |
| P1213     | Restart time increment          | 30      | 3     | CUT | N  |
| P1215     | Holding brake enable            | 0       | 2     | T   | N  |

| ParNo    | ParText                          | Default | Level | DS  | QC |
|----------|----------------------------------|---------|-------|-----|----|
| P1216    | Holding brake release delay      | 1.0     | 2     | T   | N  |
| P1217    | Holding time after ramp down     | 1.0     | 2     | T   | N  |
| P1232[3] | DC braking current               | 100     | 3     | CUT | N  |
| P1233[3] | Duration of DC braking           | 0       | 3     | CUT | N  |
| P1234[3] | DC braking start frequency       | 650.00  | 3     | CUT | N  |
| P1236[3] | Compound braking current         | 0       | 3     | CUT | N  |
| r1242    | CO: Switch-on level of Vdc-max   | -       | 3     | -   | -  |
| P1240[3] | Configuration of Vdc controller  | 1       | 3     | CT  | N  |
| P1243[3] | Dynamic factor of Vdc-max        | 100     | 3     | CUT | N  |
| P1254    | Auto detect Vdc switch-on levels | 1       | 3     | CT  | N  |
| P1253[3] | Vdc-controller output limitation | 10      | 3     | CUT | N  |
| r1261    | BO: Contactor control word       | -       | 2     | -   | -  |
| P1260[3] | source of changeover control     | 0       | 2     | CT  | N  |
| P1262[3] | Bypass dead time                 | 1.000   | 2     | CUT | N  |
| P1263[3] | De-Bypass time                   | 1.0     | 2     | CUT | N  |
| P1264[3] | Bypass time                      | 1.0     | 2     | CUT | N  |
| P1265[3] | Bypass frequency                 | 50.00   | 2     | CT  | N  |
| P1266[3] | Bl: Bypass command               | 0:0     | 2     | CT  | N  |

**Motor Control (P0004 = 13)**

| ParNo     | ParText                         | Default | Level | DS  | QC |
|-----------|---------------------------------|---------|-------|-----|----|
| r0020     | CO: Act. frequency setpoint     | -       | 3     | -   | -  |
| r0021     | CO: Act. frequency              | -       | 3     | -   | -  |
| r0022     | Act. rotor speed                | -       | 3     | -   | -  |
| r0024     | CO: Act. output frequency       | -       | 3     | -   | -  |
| r0025     | CO: Act. output voltage         | -       | 3     | -   | -  |
| r0027     | CO: Act. output current         | -       | 3     | -   | -  |
| r0032     | CO: Act. power                  | -       | 3     | -   | -  |
| r0038     | CO: Act. power factor           | -       | 3     | -   | -  |
| r0056     | CO/BO: Status of motor control  | -       | 3     | -   | -  |
| r0061     | CO: Act. rotor speed            | -       | 3     | -   | -  |
| r0065     | CO: Slip frequency              | -       | 3     | -   | -  |
| r0067     | CO: Act. output current limit   | -       | 3     | -   | -  |
| r0071     | CO: Max. output voltage         | -       | 3     | -   | -  |
| r0086     | CO: Act. active current         | -       | 3     | -   | -  |
| P0095[10] | Cl: Display PZD signals         | 0:0     | 3     | CT  | N  |
| r0096[10] | PZD signals                     | -       | 3     | -   | -  |
| P1300[3]  | Control mode                    | 1       | 3     | CT  | Q  |
| P1310[3]  | Continuous boost                | 50.0    | 3     | CUT | N  |
| P1311[3]  | Acceleration boost              | 0.0     | 3     | CUT | N  |
| P1312[3]  | Starting boost                  | 0.0     | 3     | CUT | N  |
| P1316[3]  | Boost end frequency             | 20.0    | 3     | CUT | N  |
| P1320[3]  | Programmable V/f freq. coord. 1 | 0.00    | 3     | CT  | N  |
| P1321[3]  | Programmable V/f volt. coord. 1 | 0.0     | 3     | CUT | N  |
| P1322[3]  | Programmable V/f freq. coord. 2 | 0.00    | 3     | CT  | N  |

| ParNo    | ParText                          | Default | Level | DS  | QC |
|----------|----------------------------------|---------|-------|-----|----|
| P1323[3] | Programmable V/f volt. coord. 2  | 0.0     | 3     | CUT | N  |
| P1324[3] | Programmable V/f freq. coord. 3  | 0.00    | 3     | CT  | N  |
| P1325[3] | Programmable V/f volt. coord. 3  | 0.0     | 3     | CUT | N  |
| P1330[3] | Cl: Voltage setpoint             | 0:0     | 3     | T   | N  |
| P1333[3] | Start frequency for FCC          | 10.0    | 3     | CUT | N  |
| r1337    | CO: V/f slip frequency           | -       | 3     | -   | -  |
| P1335[3] | Slip compensation                | 0.0     | 3     | CUT | N  |
| P1336[3] | Slip limit                       | 250     | 3     | CUT | N  |
| P1338[3] | Resonance damping gain V/f       | 0.00    | 3     | CUT | N  |
| P1340[3] | Imax controller prop. gain       | 0.000   | 3     | CUT | N  |
| r1343    | CO: Imax controller freq. output | -       | 3     | -   | -  |
| P1341[3] | Imax controller integral time    | 0.300   | 3     | CUT | N  |
| r1344    | CO: Imax controller volt. output | -       | 3     | -   | -  |
| P1345[3] | Imax controller prop. gain       | 0.250   | 3     | CUT | N  |
| P1346[3] | Imax controller integral time    | 0.300   | 3     | CUT | N  |
| P1350[3] | Voltage soft start               | 0       | 3     | CUT | N  |

### Communication (P0004 = 20)

| ParNo    | ParText                          | Default | Level | DS  | QC |
|----------|----------------------------------|---------|-------|-----|----|
| P0918    | CB address                       | 3       | 2     | CT  | N  |
| P0927    | Parameter changeable via         | 15      | 3     | CUT | N  |
| r0965    | Profibus profile                 | -       | 3     | -   | -  |
| r0967    | Control word 1                   | -       | 3     | -   | -  |
| r0968    | Status word 1                    | -       | 3     | -   | -  |
| r0964[5] | Firmware version data            | -       | 3     | -   | -  |
| P0971    | Transfer data from RAM to EEPROM | 0       | 3     | CUT | N  |
| P2000[3] | Reference frequency              | 50.00   | 2     | CT  | N  |
| P2001[3] | Reference voltage                | 1000    | 3     | CT  | N  |
| P2002[3] | Reference current                | 0.10    | 3     | CT  | N  |
| P2003[3] | Reference torque                 | 0.75    | 3     | CT  | N  |
| r2004[3] | Reference power                  | -       | 3     | -   | -  |
| P2009[2] | USS normalization                | 0       | 3     | CT  | N  |
| P2010[2] | USS baudrate                     | 6       | 3     | CUT | N  |
| P2011[2] | USS address                      | 0       | 3     | CUT | N  |
| P2012[2] | USS PZD length                   | 2       | 3     | CUT | N  |
| P2013[2] | USS PKW length                   | 127     | 3     | CUT | N  |
| P2014[2] | USS telegram off time            | 0       | 3     | CT  | N  |
| r2015[8] | CO: PZD from BOP link (USS)      | -       | 3     | -   | -  |
| P2016[8] | Cl: PZD to BOP link (USS)        | 52:0    | 3     | CT  | N  |
| r2018[8] | CO: PZD from COM link (USS)      | -       | 3     | -   | -  |
| r2024[2] | USS error-free telegrams         | -       | 3     | -   | -  |
| P2019[8] | Cl: PZD to COM link (USS)        | 52:0    | 3     | CT  | N  |
| r2025[2] | USS rejected telegrams           | -       | 3     | -   | -  |
| r2026[2] | USS character frame error        | -       | 3     | -   | -  |
| r2027[2] | USS overrun error                | -       | 3     | -   | -  |

| ParNo    | ParText                          | Default | Level | DS | QC |
|----------|----------------------------------|---------|-------|----|----|
| r2028[2] | USS parity error                 | -       | 3     | -  | -  |
| r2029[2] | USS start not identified         | -       | 3     | -  | -  |
| r2030[2] | USS BCC error                    | -       | 3     | -  | -  |
| r2032    | BO: CtrlWrd1 from BOP link (USS) | -       | 3     | -  | -  |
| r2031[2] | USS length error                 | -       | 3     | -  | -  |
| r2033    | BO: CtrlWrd2 from BOP link (USS) | -       | 3     | -  | -  |
| r2036    | BO: CtrlWrd1 from COM link (USS) | -       | 3     | -  | -  |
| r2037    | BO: CtrlWrd2 from COM link (USS) | -       | 3     | -  | -  |
| P2040    | CB telegram off time             | 20      | 3     | CT | N  |
| P2041[5] | CB parameter                     | 0       | 3     | CT | N  |
| r2050[8] | CO: PZD from CB                  | -       | 3     | -  | -  |
| r2053[5] | CB identification                | -       | 3     | -  | -  |
| P2051[8] | CI: PZD to CB                    | 52:0    | 3     | CT | N  |
| r2054[7] | CB diagnosis                     | -       | 3     | -  | -  |
| r2090    | BO: Control word 1 from CB       | -       | 3     | -  | -  |
| r2091    | BO: Control word 2 from CB       | -       | 3     | -  | -  |

### Alarms, Warnings and Monitoring (P0004 = 21)

| ParNo     | ParText                          | Default | Level | DS  | QC |
|-----------|----------------------------------|---------|-------|-----|----|
| r0947[8]  | Last fault code                  | -       | 3     | -   | -  |
| r0948[12] | Fault time                       | -       | 3     | -   | -  |
| r0949[8]  | Fault value                      | -       | 3     | -   | -  |
| P0952     | Total number of faults           | 0       | 3     | CT  | N  |
| P2100[3]  | Alarm number selection           | 0       | 3     | CT  | N  |
| P2101[3]  | Stop reaction value              | 0       | 3     | CT  | N  |
| r2110[4]  | Warning number                   | -       | 3     | -   | -  |
| P2111     | Total number of warnings         | 0       | 3     | CT  | N  |
| r2114[2]  | Run time counter                 | -       | 3     | -   | -  |
| P2115[3]  | AOP real time clock              | 0       | 3     | CT  | N  |
| P2150[3]  | Hysteresis frequency f_hys       | 3.00    | 3     | CUT | N  |
| P2151[3]  | CI: Monitoring speed setpoint    | 0:0     | 3     | CUT | N  |
| P2152[3]  | CI: Act. Monitoring speed        | 0:0     | 3     | CUT | N  |
| P2153[3]  | Time-constant speed filter       | 5       | 3     | CUT | N  |
| P2155[3]  | Threshold frequency f_1          | 30.00   | 3     | CUT | N  |
| P2156[3]  | Delay time of threshold freq f_1 | 10      | 3     | CUT | N  |
| P2157[3]  | Threshold frequency f_2          | 30.00   | 3     | CUT | N  |
| P2158[3]  | Delay time of threshold freq f_2 | 10      | 3     | CUT | N  |
| P2159[3]  | Threshold frequency f_3          | 30.00   | 3     | CUT | N  |
| P2160[3]  | Delay time of threshold freq f_3 | 10      | 3     | CUT | N  |
| P2161[3]  | Min. threshold for freq. Setp.   | 3.00    | 3     | CUT | N  |
| P2162[3]  | Hysteresis freq. For overspeed   | 20.00   | 3     | CUT | N  |
| P2163[3]  | Entry freq. For perm. Deviation  | 3.00    | 3     | CUT | N  |
| P2164[3]  | Hysteresis frequency deviation   | 3.00    | 3     | CUT | N  |
| P2165[3]  | Delay time permitted deviation   | 10      | 3     | CUT | N  |
| P2166[3]  | Delay time ramp up completed     | 10      | 3     | CUT | N  |



| ParNo    | ParText                          | Default | Level | DS  | QC |
|----------|----------------------------------|---------|-------|-----|----|
| P2167[3] | Switch-off frequency f_off       | 1.00    | 3     | CUT | N  |
| P2168[3] | Delay time T_off                 | 10      | 3     | CUT | N  |
| r2169    | CO: Act. Filtered frequency      | -       | 3     | -   | -  |
| P2170[3] | Threshold current I_thresh       | 100.0   | 3     | CUT | N  |
| P2171[3] | Delay time current               | 10      | 3     | CUT | N  |
| P2172[3] | Threshold DC-link voltage        | 800     | 3     | CUT | N  |
| P2173[3] | Delay time DC-link voltage       | 10      | 3     | CUT | N  |
| P2174[3] | Torque threshold T_thresh        | 5.13    | 3     | CUT | N  |
| P2176[3] | Delay time for torque threshold  | 10      | 3     | CUT | N  |
| P2177[3] | Delay time for motor is blocked  | 10      | 3     | CUT | N  |
| P2178[3] | Delay time for motor pulled out  | 10      | 3     | CUT | N  |
| P2179    | Current limit for no load ident. | 3.0     | 3     | CUT | N  |
| P2180    | Delay time for no load ident.    | 2000    | 3     | CUT | N  |
| P2181[3] | Belt failure detection mode      | 0       | 3     | CT  | N  |
| P2182[3] | Belt threshold frequency 1       | 5.00    | 3     | CUT | N  |
| P2183[3] | Belt threshold frequency 2       | 30.00   | 3     | CUT | N  |
| P2184[3] | Belt threshold frequency 3       | 50.00   | 3     | CUT | N  |
| P2185[3] | Upper torque threshold 1         | 99999.0 | 3     | CUT | N  |
| P2186[3] | Lower torque threshold 1         | 0.0     | 3     | CUT | N  |
| P2187[3] | Upper torque threshold 2         | 99999.0 | 3     | CUT | N  |
| P2188[3] | Lower torque threshold 2         | 0.0     | 3     | CUT | N  |
| P2189[3] | Upper torque threshold 3         | 99999.0 | 3     | CUT | N  |
| P2190[3] | Lower torque threshold 3         | 0.0     | 3     | CUT | N  |
| P2192[3] | Time delay for belt failure      | 10      | 3     | CUT | N  |
| r2197    | CO/BO: Monitoring word 1         | -       | 3     | -   | -  |
| r2198    | CO/BO: Monitoring word 2         | -       | 3     | -   | -  |

### PI Controller (P0004 = 22)

| ParNo    | ParText                   | Default | Level | DS  | QC |
|----------|---------------------------|---------|-------|-----|----|
| P2200[3] | BI: Enable PID controller | 0:0     | 2     | CUT | N  |
| P2201[3] | Fixed PID setpoint 1      | 0.00    | 3     | CUT | N  |
| P2202[3] | Fixed PID setpoint 2      | 10.00   | 3     | CUT | N  |
| P2203[3] | Fixed PID setpoint 3      | 20.00   | 3     | CUT | N  |
| P2204[3] | Fixed PID setpoint 4      | 30.00   | 3     | CUT | N  |
| P2205[3] | Fixed PID setpoint 5      | 40.00   | 3     | CUT | N  |
| P2206[3] | Fixed PID setpoint 6      | 50.00   | 3     | CUT | N  |
| P2207[3] | Fixed PID setpoint 7      | 60.00   | 3     | CUT | N  |
| P2208[3] | Fixed PID setpoint 8      | 70.00   | 3     | CUT | N  |
| P2209[3] | Fixed PID setpoint 9      | 80.00   | 3     | CUT | N  |
| P2210[3] | Fixed PID setpoint 10     | 90.00   | 3     | CUT | N  |
| P2211[3] | Fixed PID setpoint 11     | 100.00  | 3     | CUT | N  |
| P2212[3] | Fixed PID setpoint 12     | 110.00  | 3     | CUT | N  |
| P2213[3] | Fixed PID setpoint 13     | 120.00  | 3     | CUT | N  |
| P2214[3] | Fixed PID setpoint 14     | 130.00  | 3     | CUT | N  |
| P2215[3] | Fixed PID setpoint 15     | 130.00  | 3     | CUT | N  |

| ParNo    | ParText                          | Default | Level | DS  | QC |
|----------|----------------------------------|---------|-------|-----|----|
| P2216    | Fixed PID setpoint mode - Bit 0  | 1       | 3     | CT  | N  |
| P2217    | Fixed PID setpoint mode - Bit 1  | 1       | 3     | CT  | N  |
| P2218    | Fixed PID setpoint mode - Bit 2  | 1       | 3     | CT  | N  |
| P2219    | Fixed PID setpoint mode - Bit 3  | 1       | 3     | CT  | N  |
| r2224    | CO: Act. fixed PID setpoint      | -       | 3     | -   | -  |
| P2225    | Fixed PID setpoint mode - Bit 4  | 1       | 3     | CT  | N  |
| P2227    | Fixed PID setpoint mode - Bit 5  | 1       | 3     | CT  | N  |
| P2232    | Inhibit rev. direct. of PID-MOP  | 1       | 3     | CT  | N  |
| P2231[3] | Setpoint memory of PID-MOP       | 1       | 3     | CUT | N  |
| P2240[3] | Setpoint of PID-MOP              | 10.00   | 3     | CUT | N  |
| r2250    | CO: Output setpoint of PID-MOP   | -       | 3     | -   | -  |
| P2255    | PID setpoint gain factor         | 100.00  | 3     | CUT | N  |
| P2253[3] | CI: PID setpoint                 | 2250:0  | 2     | CUT | N  |
| P2256    | PID trim gain factor             | 100.00  | 3     | CUT | N  |
| P2257    | Ramp-up time for PID setpoint    | 1.00    | 2     | CUT | N  |
| P2254[3] | CI: PID trim source              | 0:0     | 3     | CUT | N  |
| P2258    | Ramp-down time for PID setpoint  | 1.00    | 2     | CUT | N  |
| r2260    | CO: PID setpoint after PID-RFG   | -       | 2     | -   | -  |
| P2261    | PID setpoint filter timeconstant | 0.00    | 3     | CUT | N  |
| r2262    | CO: Filtered PID setp. after RFG | -       | 3     | -   | -  |
| P2263    | PID controller type              | 0       | 3     | T   | N  |
| P2265    | PID feedback filter timeconstant | 0.00    | 2     | CUT | N  |
| r2266    | CO: PID filtered feedback        | -       | 2     | -   | -  |
| P2264[3] | CI: PID feedback                 | 755:1   | 2     | CUT | N  |
| P2267    | Max. value for PID feedback      | 100.00  | 3     | CUT | N  |
| P2268    | Min. value for PID feedback      | 0.00    | 3     | CUT | N  |
| P2269    | Gain applied to PID feedback     | 100.00  | 3     | CUT | N  |
| P2270    | PID feedback function selector   | 0       | 3     | CUT | N  |
| P2271    | PID transducer type              | 0       | 2     | CUT | N  |
| r2272    | CO: PID scaled feedback          | -       | 2     | -   | -  |
| r2273    | CO: PID error                    | -       | 2     | -   | -  |
| P2274    | PID derivative time              | 0.000   | 2     | CUT | N  |
| P2280    | PID proportional gain            | 3.000   | 2     | CUT | N  |
| P2285    | PID integral time                | 0.000   | 2     | CUT | N  |
| P2291    | PID output upper limit           | 100.00  | 2     | CUT | N  |
| P2292    | PID output lower limit           | 0.00    | 2     | CUT | N  |
| P2293    | Ramp-up /-down time of PID limit | 1.00    | 3     | CUT | N  |
| r2294    | CO: Act. PID output              | -       | 2     | -   | -  |
| P2370[3] | Motor staging stop mode          | 0       | 3     | CT  | N  |
| P2371[3] | External motor configuration     | 0       | 3     | CT  | N  |
| P2372[3] | Enable motor cycling             | 0       | 3     | CT  | N  |
| P2373[3] | Motor staging hysteresis         | 20.0    | 3     | CUT | N  |
| P2374[3] | Motor staging delay              | 30      | 3     | CUT | N  |
| P2375[3] | Motor destaging delay            | 30      | 3     | CUT | N  |
| P2376[3] | Delay override                   | 25.0    | 3     | CUT | N  |

| ParNo     | ParText                        | Default | Level | DS  | QC |
|-----------|--------------------------------|---------|-------|-----|----|
| P2377[3]  | Delay override lockout timer   | 30      | 3     | CUT | N  |
| P2378[3]  | Staging frequency f, %fMax     | 50.0    | 3     | CUT | N  |
| r2379     | CO/BO: Status of motor staging | -       | 3     | -   | -  |
| P2380[3]  | Motor hours run                | 0       | 3     | CUT | N  |
| P2390     | Energy saving setpoint         | 0       | 3     | CUT | N  |
| P2391     | Energy saving timer            | 0       | 3     | CT  | N  |
| P2392     | Energy saving restart setpoint | 0       | 3     | CT  | N  |
| P2800     | Enable FFBs                    | 0       | 3     | CUT | N  |
| r2811     | BO: AND 1                      | -       | 3     | -   | -  |
| P2810[2]  | BI: AND 1                      | 0:0     | 3     | CUT | N  |
| r2813     | BO: AND 2                      | -       | 3     | -   | -  |
| P2812[2]  | BI: AND 2                      | 0:0     | 3     | CUT | N  |
| r2815     | BO: AND 3                      | -       | 3     | -   | -  |
| P2802[14] | Activate FFBs                  | 0       | 3     | CUT | N  |
| P2814[2]  | BI: AND 3                      | 0:0     | 3     | CUT | N  |
| r2817     | BO: OR 1                       | -       | 3     | -   | -  |
| P2801[17] | Activate FFBs                  | 0       | 3     | CUT | N  |
| P2816[2]  | BI: OR 1                       | 0:0     | 3     | CUT | N  |
| r2819     | BO: OR 2                       | -       | 3     | -   | -  |
| P2818[2]  | BI: OR 2                       | 0:0     | 3     | CUT | N  |
| r2821     | BO: OR 3                       | -       | 3     | -   | -  |
| P2820[2]  | BI: OR 3                       | 0:0     | 3     | CUT | N  |
| r2823     | BO: XOR 1                      | -       | 3     | -   | -  |
| P2822[2]  | BI: XOR 1                      | 0:0     | 3     | CUT | N  |
| r2825     | BO: XOR 2                      | -       | 3     | -   | -  |
| P2824[2]  | BI: XOR 2                      | 0:0     | 3     | CUT | N  |
| r2827     | BO: XOR 3                      | -       | 3     | -   | -  |
| P2826[2]  | BI: XOR 3                      | 0:0     | 3     | CUT | N  |
| P2828     | BI: NOT 1                      | 0:0     | 3     | CUT | N  |
| r2829     | BO: NOT 1                      | -       | 3     | -   | -  |
| P2830     | BI: NOT 2                      | 0:0     | 3     | CUT | N  |
| r2831     | BO: NOT 2                      | -       | 3     | -   | -  |
| P2832     | BI: NOT 3                      | 0:0     | 3     | CUT | N  |
| r2833     | BO: NOT 3                      | -       | 3     | -   | -  |
| r2835     | BO: Q D-FF 1                   | -       | 3     | -   | -  |
| r2836     | BO: NOT-Q D-FF 1               | -       | 3     | -   | -  |
| P2834[4]  | BI: D-FF 1                     | 0:0     | 3     | CUT | N  |
| r2838     | BO: Q D-FF 2                   | -       | 3     | -   | -  |
| r2839     | BO: NOT-Q D-FF 2               | -       | 3     | -   | -  |
| P2837[4]  | BI: D-FF 2                     | 0:0     | 3     | CUT | N  |
| r2841     | BO: Q RS-FF 1                  | -       | 3     | -   | -  |
| P2840[2]  | BI: RS-FF 1                    | 0:0     | 3     | CUT | N  |
| r2842     | BO: NOT-Q RS-FF 1              | -       | 3     | -   | -  |
| r2844     | BO: Q RS-FF 2                  | -       | 3     | -   | -  |
| P2843[2]  | BI: RS-FF 2                    | 0:0     | 3     | CUT | N  |

| ParNo    | ParText                     | Default | Level | DS  | QC |
|----------|-----------------------------|---------|-------|-----|----|
| r2845    | BO: NOT-Q RS-FF 2           | -       | 3     | -   | -  |
| P2846[2] | BI: RS-FF 3                 | 0:0     | 3     | CUT | N  |
| r2847    | BO: Q RS-FF 3               | -       | 3     | -   | -  |
| r2848    | BO: NOT-Q RS-FF 3           | -       | 3     | -   | -  |
| P2849    | BI: Timer 1                 | 0:0     | 3     | CUT | N  |
| P2850    | Delay time of timer 1       | 0       | 3     | CUT | N  |
| P2851    | Mode timer 1                | 0       | 3     | CUT | N  |
| r2852    | BO: Timer 1                 | -       | 3     | -   | -  |
| r2853    | BO: Nout timer 1            | -       | 3     | -   | -  |
| P2854    | BI: Timer 2                 | 0:0     | 3     | CUT | N  |
| P2855    | Delay time of timer 2       | 0       | 3     | CUT | N  |
| P2856    | Mode timer 2                | 0       | 3     | CUT | N  |
| r2857    | BO: Timer 2                 | -       | 3     | -   | -  |
| r2858    | BO: Nout timer 2            | -       | 3     | -   | -  |
| P2859    | BI: Timer 3                 | 0:0     | 3     | CUT | N  |
| P2860    | Delay time of timer 3       | 0       | 3     | CUT | N  |
| P2861    | Mode timer 3                | 0       | 3     | CUT | N  |
| r2862    | BO: Timer 3                 | -       | 3     | -   | -  |
| r2863    | BO: Nout timer 3            | -       | 3     | -   | -  |
| P2864    | BI: Timer 4                 | 0:0     | 3     | CUT | N  |
| P2865    | Delay time of timer 4       | 0       | 3     | CUT | N  |
| P2866    | Mode timer 4                | 0       | 3     | CUT | N  |
| r2867    | BO: Timer 4                 | -       | 3     | -   | -  |
| r2868    | BO: Nout timer 4            | -       | 3     | -   | -  |
| r2870    | CO: ADD 1                   | -       | 3     | -   | -  |
| P2869[2] | CI: ADD 1                   | 755:0   | 3     | CUT | N  |
| r2872    | CO: ADD 2                   | -       | 3     | -   | -  |
| P2871[2] | CI: ADD 2                   | 755:0   | 3     | CUT | N  |
| r2874    | CO: SUB 1                   | -       | 3     | -   | -  |
| P2873[2] | CI: SUB 1                   | 755:0   | 3     | CUT | N  |
| r2876    | CO: SUB 2                   | -       | 3     | -   | -  |
| P2875[2] | CI: SUB 2                   | 755:0   | 3     | CUT | N  |
| r2878    | CO: MUL 1                   | -       | 3     | -   | -  |
| P2877[2] | CI: MUL 1                   | 755:0   | 3     | CUT | N  |
| r2880    | CO: MUL 2                   | -       | 3     | -   | -  |
| P2879[2] | CI: MUL 2                   | 755:0   | 3     | CUT | N  |
| r2882    | CO: DIV 1                   | -       | 3     | -   | -  |
| P2881[2] | CI: DIV 1                   | 755:0   | 3     | CUT | N  |
| r2884    | CO: DIV 2                   | -       | 3     | -   | -  |
| P2883[2] | CI: DIV 2                   | 755:0   | 3     | CUT | N  |
| r2886    | BO: CMP 1                   | -       | 3     | -   | -  |
| P2885[2] | CI: CMP 1                   | 755:0   | 3     | CUT | N  |
| r2888    | BO: CMP 2                   | -       | 3     | -   | -  |
| P2887[2] | CI: CMP 2                   | 755:0   | 3     | CUT | N  |
| P2889    | CO: Fixed setpoint 1 in [%] | 0       | 3     | CUT | N  |
| P2890    | CO: Fixed setpoint 2 in [%] | 0       | 3     | CUT | N  |

## 5.4 Command and Drive Datasets - Overview

### Command Datasets (CDS)

| ParNo    | ParText                          |
|----------|----------------------------------|
| P0700[3] | Selection of command source      |
| P0701[3] | Function of digital input 1      |
| P0702[3] | Function of digital input 2      |
| P0703[3] | Function of digital input 3      |
| P0704[3] | Function of digital input 4      |
| P0705[3] | Function of digital input 5      |
| P0706[3] | Function of digital input 6      |
| P0707[3] | Function of digital input 7      |
| P0708[3] | Function of digital input 8      |
| P0719[3] | Selection of cmd. & freq. setp.  |
| P0731[3] | BI: Function of digital output 1 |
| P0732[3] | BI: Function of digital output 2 |
| P0733[3] | BI: Function of digital output 3 |
| P0800[3] | BI: Download parameter set 0     |
| P0801[3] | BI: Download parameter set 1     |
| P0840[3] | BI: ON/OFF1                      |
| P0842[3] | BI: ON reverse/OFF1              |
| P0844[3] | BI: 1. OFF2                      |
| P0845[3] | BI: 2. OFF2                      |
| P0848[3] | BI: 1. OFF3                      |
| P0849[3] | BI: 2. OFF3                      |
| P0852[3] | BI: Pulse enable                 |
| P1000[3] | Selection of frequency setpoint  |
| P1020[3] | BI: Fixed freq. selection Bit 0  |
| P1021[3] | BI: Fixed freq. selection Bit 1  |
| P1022[3] | BI: Fixed freq. selection Bit 2  |
| P1023[3] | BI: Fixed freq. selection Bit 3  |
| P1026[3] | BI: Fixed freq. selection Bit 4  |
| P1028[3] | BI: Fixed freq. selection Bit 5  |
| P1035[3] | BI: Enable MOP (UP-command)      |
| P1036[3] | BI: Enable MOP (DOWN-command)    |
| P1055[3] | BI: Enable JOG right             |
| P1056[3] | BI: Enable JOG left              |
| P1070[3] | CI: Main setpoint                |
| P1071[3] | CI: Main setpoint scaling        |
| P1074[3] | BI: Disable additional setpoint  |
| P1075[3] | CI: Additional setpoint          |
| P1076[3] | CI: Additional setpoint scaling  |
| P1110[3] | BI: Inhibit neg. freq. setpoint  |
| P1113[3] | BI: Reverse                      |
| P1124[3] | BI: Enable JOG ramp times        |

| ParNo    | ParText                          |
|----------|----------------------------------|
| P1140[3] | BI: RFG enable                   |
| P1141[3] | BI: RFG start                    |
| P1142[3] | BI: RFG enable setpoint          |
| P1230[3] | BI: Enable DC braking            |
| P1266[3] | BI: Bypass command               |
| P1270[3] | BI: Enable essential service     |
| P1330[3] | CI: Voltage setpoint             |
| P1477[3] | BI: Set integrator of n-ctrl.    |
| P1478[3] | CI: Set integrator value n-ctrl. |
| P1500[3] | Selection of torque setpoint     |
| P1501[3] | BI: Change to torque control     |
| P1503[3] | CI: Torque setpoint              |
| P1511[3] | CI: Additional torque setpoint   |
| P1522[3] | CI: Upper torque limit           |
| P1523[3] | CI: Lower torque limit           |
| P2103[3] | BI: 1. Faults acknowledgement    |
| P2104[3] | BI: 2. Faults acknowledgement    |
| P2106[3] | BI: External fault               |
| P2151[3] | CI: Monitoring speed setpoint    |
| P2152[3] | CI: Act. monitoring speed        |
| P2200[3] | BI: Enable PID controller        |
| P2220[3] | BI: Fixed PID setp. select Bit 0 |
| P2221[3] | BI: Fixed PID setp. select Bit 1 |
| P2222[3] | BI: Fixed PID setp. select Bit 2 |
| P2223[3] | BI: Fixed PID setp. select Bit 3 |
| P2226[3] | BI: Fixed PID setp. select Bit 4 |
| P2228[3] | BI: Fixed PID setp. select Bit 5 |
| P2235[3] | BI: Enable PID-MOP (UP-cmd)      |
| P2236[3] | BI: Enable PID-MOP (DOWN-cmd)    |
| P2253[3] | CI: PID setpoint                 |
| P2254[3] | CI: PID trim source              |
| P2264[3] | CI: PID feedback                 |

**Drive Datasets (DDS)**

| ParNo    | ParText                            |
|----------|------------------------------------|
| P0005[3] | Display selection                  |
| r0035[3] | CO: Act. motor temperature         |
| P0291[3] | Inverter protection                |
| P0300[3] | Select motor type                  |
| P0304[3] | Rated motor voltage                |
| P0305[3] | Rated motor current                |
| P0307[3] | Rated motor power                  |
| P0308[3] | Rated motor cosPhi                 |
| P0309[3] | Rated motor efficiency             |
| P0310[3] | Rated motor frequency              |
| P0311[3] | Rated motor speed                  |
| r0313[3] | Motor pole pairs                   |
| P0314[3] | Motor pole pair number             |
| P0320[3] | Motor magnetizing current          |
| r0330[3] | Rated motor slip                   |
| r0331[3] | Rated magnetization current        |
| r0332[3] | Rated power factor                 |
| r0333[3] | Rated motor torque                 |
| P0335[3] | Motor cooling                      |
| P0340[3] | Calculation of motor parameters    |
| P0341[3] | Motor inertia [kg*m <sup>2</sup> ] |
| P0342[3] | Total/motor inertia ratio          |
| P0344[3] | Motor weight                       |
| r0345[3] | Motor start-up time                |
| P0346[3] | Magnetization time                 |
| P0347[3] | Demagnetization time               |
| P0350[3] | Stator resistance (line-to-line)   |
| P0352[3] | Cable resistance                   |
| P0354[3] | Rotor resistance                   |
| P0356[3] | Stator leakage inductance          |
| P0358[3] | Rotor leakage inductance           |
| P0360[3] | Main inductance                    |
| P0362[3] | Magnetizing curve flux 1           |
| P0363[3] | Magnetizing curve flux 2           |
| P0364[3] | Magnetizing curve flux 3           |
| P0365[3] | Magnetizing curve flux 4           |
| P0366[3] | Magnetizing curve imag 1           |
| P0367[3] | Magnetizing curve imag 2           |
| P0368[3] | Magnetizing curve imag 3           |
| P0369[3] | Magnetizing curve imag 4           |
| r0370[3] | Stator resistance [%]              |
| r0372[3] | Cable resistance [%]               |
| r0373[3] | Rated stator resistance [%]        |
| r0374[3] | Rotor resistance [%]               |

| ParNo    | ParText                        |
|----------|--------------------------------|
| r0376[3] | Rated rotor resistance [%]     |
| r0377[3] | Total leakage reactance [%]    |
| r0382[3] | Main reactance [%]             |
| r0384[3] | Rotor time constant            |
| r0386[3] | Total leakage time constant    |
| P0400[3] | Select encoder type            |
| P0408[3] | Encoder pulses per revolution  |
| P0491[3] | Reaction on speed signal loss  |
| P0492[3] | Allowed speed difference       |
| P0494[3] | Delay speed loss reaction      |
| P0500[3] | Technological application      |
| P0601[3] | Motor temperature sensor       |
| P0604[3] | Threshold motor temperature    |
| P0625[3] | Ambient motor temperature      |
| P0626[3] | Overtemperature stator iron    |
| P0627[3] | Overtemperature stator winding |
| P0628[3] | Overtemperature rotor winding  |
| r0630[3] | CO: Ambient temperature        |
| r0631[3] | CO: Stator iron temperature    |
| r0632[3] | CO: Stator winding temperature |
| r0633[3] | CO: Rotor winding temperature  |
| P0640[3] | Motor overload factor [%]      |
| P1001[3] | Fixed frequency 1              |
| P1002[3] | Fixed frequency 2              |
| P1003[3] | Fixed frequency 3              |
| P1004[3] | Fixed frequency 4              |
| P1005[3] | Fixed frequency 5              |
| P1006[3] | Fixed frequency 6              |
| P1007[3] | Fixed frequency 7              |
| P1008[3] | Fixed frequency 8              |
| P1009[3] | Fixed frequency 9              |
| P1010[3] | Fixed frequency 10             |
| P1011[3] | Fixed frequency 11             |
| P1012[3] | Fixed frequency 12             |
| P1013[3] | Fixed frequency 13             |
| P1014[3] | Fixed frequency 14             |
| P1015[3] | Fixed frequency 15             |
| P1031[3] | Setpoint memory of the MOP     |
| P1040[3] | Setpoint of the MOP            |
| P1058[3] | JOG frequency right            |
| P1059[3] | JOG frequency left             |
| P1060[3] | JOG ramp-up time               |
| P1061[3] | JOG ramp-down time             |
| P1080[3] | Min. frequency                 |

| ParNo    | ParText                          |
|----------|----------------------------------|
| P1082[3] | Max. frequency                   |
| P1091[3] | Skip frequency 1                 |
| P1092[3] | Skip frequency 2                 |
| P1093[3] | Skip frequency 3                 |
| P1094[3] | Skip frequency 4                 |
| P1101[3] | Skip frequency bandwidth         |
| P1120[3] | Ramp-up time                     |
| P1121[3] | Ramp-down time                   |
| P1130[3] | Ramp-up initial rounding time    |
| P1131[3] | Ramp-up final rounding time      |
| P1132[3] | Ramp-down initial rounding time  |
| P1133[3] | Ramp-down final rounding time    |
| P1134[3] | Rounding type                    |
| P1135[3] | OFF3 ramp-down time              |
| P1202[3] | Motor-current: Flying start      |
| P1203[3] | Search rate: Flying start        |
| P1232[3] | DC braking current               |
| P1233[3] | Duration of DC braking           |
| P1234[3] | DC braking start frequency       |
| P1236[3] | Compound braking current         |
| P1240[3] | Configuration of Vdc controller  |
| P1243[3] | Dynamic factor of Vdc-max        |
| P1250[3] | Gain of Vdc-controller           |
| P1251[3] | Integration time Vdc-controller  |
| P1252[3] | Differential time Vdc-controller |
| P1253[3] | Vdc-controller output limitation |
| P1260[3] | Bypass control                   |
| P1262[3] | Bypass dead time                 |
| P1263[3] | De-Bypass time                   |
| P1264[3] | Bypass time                      |
| P1265[3] | Bypass frequency                 |
| P1300[3] | Control mode                     |
| P1310[3] | Continuous boost                 |
| P1311[3] | Acceleration boost               |
| P1312[3] | Starting boost                   |
| P1316[3] | Boost end frequency              |
| P1320[3] | Programmable V/f freq. coord. 1  |
| P1321[3] | Programmable V/f volt. coord. 1  |
| P1322[3] | Programmable V/f freq. coord. 2  |
| P1323[3] | Programmable V/f volt. coord. 2  |
| P1324[3] | Programmable V/f freq. coord. 3  |
| P1325[3] | Programmable V/f volt. coord. 3  |
| P1333[3] | Start frequency for FCC          |
| P1335[3] | Slip compensation                |
| P1336[3] | Slip limit                       |

| ParNo    | ParText                          |
|----------|----------------------------------|
| P1338[3] | Resonance damping gain V/f       |
| P1340[3] | Imax controller prop. gain       |
| P1341[3] | Imax controller integral time    |
| P1345[3] | Imax controller prop. gain       |
| P1346[3] | Imax controller integral time    |
| P1350[3] | Voltage soft start               |
| P1400[3] | Configuration of speed control   |
| P1442[3] | Filter time for act. speed       |
| P1452[3] | Filter time for act.speed (SLVC) |
| P1460[3] | Gain speed controller            |
| P1462[3] | Integral time speed controller   |
| P1470[3] | Gain speed controller (SLVC)     |
| P1472[3] | Integral time n-ctrl. (SLVC)     |
| P1488[3] | Droop input source               |
| P1489[3] | Droop scaling                    |
| P1492[3] | Enable droop                     |
| P1496[3] | Scaling accel. precontrol        |
| P1499[3] | Scaling accel. torque control    |
| P1520[3] | CO: Upper torque limit           |
| P1521[3] | CO: Lower torque limit           |
| P1525[3] | Scaling lower torque limit       |
| P1530[3] | Motoring power limitation        |
| P1531[3] | Regenerative power limitation    |
| P1654[3] | Smooth time for Isq setpoint     |
| P1715[3] | Gain current controller          |
| P1717[3] | Integral time current controller |
| P1803[3] | Max. modulation                  |
| P1820[3] | Reverse output phase sequence    |
| P2000[3] | Reference frequency              |
| P2001[3] | Reference voltage                |
| P2002[3] | Reference current                |
| P2003[3] | Reference torque                 |
| r2004[3] | Reference power                  |
| P2150[3] | Hysteresis frequency f_hys       |
| P2153[3] | Time-constant speed filter       |
| P2155[3] | Threshold frequency f_1          |
| P2156[3] | Delay time of threshold freq f_1 |
| P2157[3] | Threshold frequency f_2          |
| P2158[3] | Delay time of threshold freq f_2 |
| P2159[3] | Threshold frequency f_3          |
| P2160[3] | Delay time of threshold freq f_3 |
| P2161[3] | Min. threshold for freq. setp.   |
| P2162[3] | Hysteresis freq. for overspeed   |
| P2163[3] | Entry freq. for perm. deviation  |
| P2164[3] | Hysteresis frequency deviation   |

| ParNo    | ParText                         |
|----------|---------------------------------|
| P2165[3] | Delay time permitted deviation  |
| P2166[3] | Delay time ramp up completed    |
| P2167[3] | Switch-off frequency f_off      |
| P2168[3] | Delay time T_off                |
| P2170[3] | Threshold current I_thresh      |
| P2171[3] | Delay time current              |
| P2172[3] | Threshold DC-link voltage       |
| P2173[3] | Delay time DC-link voltage      |
| P2174[3] | Torque threshold T_thresh       |
| P2176[3] | Delay time for torque threshold |
| P2177[3] | Delay time for motor is blocked |
| P2178[3] | Delay time for motor pulled out |
| P2181[3] | Belt failure detection mode     |
| P2182[3] | Belt threshold frequency 1      |
| P2183[3] | Belt threshold frequency 2      |
| P2184[3] | Belt threshold frequency 3      |
| P2185[3] | Upper torque threshold 1        |
| P2186[3] | Lower torque threshold 1        |
| P2187[3] | Upper torque threshold 2        |
| P2188[3] | Lower torque threshold 2        |
| P2189[3] | Upper torque threshold 3        |
| P2190[3] | Lower torque threshold 3        |
| P2192[3] | Time delay for belt failure     |
| P2201[3] | Fixed PID setpoint 1            |
| P2202[3] | Fixed PID setpoint 2            |

| ParNo    | ParText                          |
|----------|----------------------------------|
| P2203[3] | Fixed PID setpoint 3             |
| P2204[3] | Fixed PID setpoint 4             |
| P2205[3] | Fixed PID setpoint 5             |
| P2206[3] | Fixed PID setpoint 6             |
| P2207[3] | Fixed PID setpoint 7             |
| P2208[3] | Fixed PID setpoint 8             |
| P2209[3] | Fixed PID setpoint 9             |
| P2210[3] | Fixed PID setpoint 10            |
| P2211[3] | Fixed PID setpoint 11            |
| P2212[3] | Fixed PID setpoint 12            |
| P2213[3] | Fixed PID setpoint 13            |
| P2214[3] | Fixed PID setpoint 14            |
| P2215[3] | Fixed PID setpoint 15            |
| P2231[3] | Setpoint memory of PID-MOP       |
| P2240[3] | Setpoint of PID-MOP              |
| P2370[3] | Motor staging stop mode          |
| P2371[3] | Motor staging configuration      |
| P2372[3] | Motor staging cycling            |
| P2373[3] | Motor staging hysteresis         |
| P2374[3] | Motor staging delay              |
| P2375[3] | Motor destaging delay            |
| P2376[3] | Motor staging delay override     |
| P2377[3] | Motor staging lockout timer      |
| P2378[3] | Motor staging frequency f_st [%] |



## 6 Troubleshooting

### This Chapter contains:

- An overview of the operating statuses of the inverter with the SDP
- Notes on troubleshooting with the BOP-2
- A list of the alarms and fault messages

|     |                                     |    |
|-----|-------------------------------------|----|
| 6.1 | Troubleshooting with the SDP .....  | 90 |
| 6.2 | Troubleshooting with the BOP-2..... | 91 |
| 6.3 | Fault messages.....                 | 92 |
| 6.4 | Alarm Messages .....                | 98 |

**WARNING**

Repairs on equipment may only be carried out by **Siemens Service**, by repair centers **authorized by Siemens** or by qualified personnel who are thoroughly acquainted with all the warnings and operating procedures contained in this manual.

Any defective parts or components must be replaced using parts contained in the relevant spare parts list.

Disconnect the power supply before opening the equipment for access.

## 6.1 Troubleshooting with the SDP

Table 6-1 explains the meaning of the various states of the LEDs on the SDP.

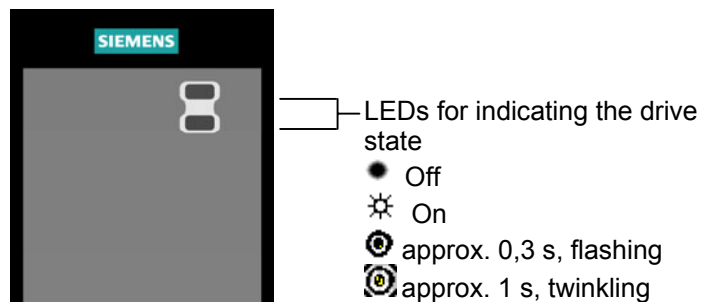

Table 6-1 Inverter conditions indicated by the LEDs on the SDP

|      |   |       |  |
|------|---|-------|--|
| ● ●  | Mains not present                                 | ☀     | Fault inverter temperature                                   |
| ☀ ☀  | Ready to run                                      | ☀⊙ ☀⊙ | Warning current limit - both LEDs twinkling <b>same time</b> |
| ● ☀  | Inverter fault - other than the ones listed below | ☀⊙ ☀⊙ | Other warnings - both LEDs twinkling <b>alternatively</b>    |
| ☀ ●  | Inverter running                                  | ☀⊙ ☀  | Undervoltage trip / undervoltage warning                     |
| ● ☀⊙ | Fault overcurrent                                 | ☀⊙ ☀⊙ | Drive is not in ready state                                  |
| ☀⊙ ● | Fault overvoltage                                 | ☀⊙ ☀⊙ | ROM failure - Both LEDs flashing <b>same time</b>            |
| ☀⊙ ☀ | Fault motor overtemperature                       | ☀⊙ ☀⊙ | RAM failure - Both LEDs flashing <b>alternatively</b>        |

## 6.2 Troubleshooting with the BOP-2

Warnings and faults are displayed on the BOP-2 with Axxx and Fxxx respectively. The individual messages are shown in Section 6.3.

If the motor fails to start when the ON command has been given:

- Check that P0010 = 0.
- Check that a valid ON signal is present.
- Check that P0700 = 2 (for digital input control) or P0700 = 1 (for BOP-2 control).
- Check that the setpoint is present (0 to 10V on Terminal 3) or the setpoint has been entered into the correct parameter, depending upon the setpoint source (P1000). See the Parameter List for further details.

If the motor fails to run after changing the parameters, set P0010 = 30 then P0970 = 1 and press **P** to reset the inverter to the factory default parameter values.

Now use a switch between terminals **5** and **9** on the control board. The drive should now run to the defined setpoint by analogue input.

---

### NOTICE

Motor data must relate to the inverter data power range and voltage.

---

## 6.3 Fault messages

In the event of a failure, the inverter switches off and a fault code appears on the display.

### NOTE

To reset the fault code, one of three methods listed below can be used:

1. Cycle the power to the drive.
2. Press the  button on the BOP-2.
3. Via Digital Input 3 (default setting)

Fault messages are stored in parameter r0947 under their code number (e.g. F0003 = 3). The associated error value is found in parameter r0949. The value 0 is entered if a fault has no error value. It is furthermore possible to read out the point in time that a fault occurred (r0948) and the number of fault messages (P0952) stored in Parameter r0947.

### F0001 OverCurrent

OFF2

#### Possible Causes

- Motor power (P0307) does not correspond to the inverter power (r0206)
- Motor leads are too long
- Motor lead short circuit
- Earth faults

#### Diagnose & Remedy

Check the following:

- Motor power (P0307) must correspond to inverter power (r0206)
- Cable length limits must not be exceeded
- Motor cable and motor must have no short-circuits or earth faults
- Motor parameters must match the motor in use
- Value of stator resistance (P0350) must be correct
- Motor must not be obstructed or overloaded
- Increase the ramp time
- Reduce the boost level (V/f control: P1311 & P1312)

### F0002 OverVoltage

OFF2

#### Possible Causes

- DC-link controller disabled (P1240 = 0)
- DC-link voltage (r0026) exceeds trip level (P2172)
- Overvoltage can be caused either by too high main supply voltage or if motor is in regenerative mode. Regenerative mode can be caused by fast ramp downs or if the motor is driven from an active load.

#### Diagnose & Remedy

Check the following:

1. Supply voltage (P0210) must lie within limits indicated on rating plate
2. DC-link voltage controller must be enabled (P1240) and parameterized properly
3. Ramp-down time (P1121) must match inertia of load
4. Required braking power must lie within specified limits

**F0003 UnderVoltage OFF2****Possible Causes**

- Main supply failed
- Shock load outside specified limits

**Diagnose & Remedy**

Check the following:

1. Supply voltage (P0210) must lie within limits indicated on rating plate
  2. Supply must not be susceptible to temporary failures or voltage reductions
- Enable kinetic buffering (P1240 = 2)

**F0004 Inverter Over Temperature OFF2****Possible Causes**

- Ventilation inadequate
- Ambient temperature is too high

**Diagnose & Remedy**

Check the following:

1. Load conditions and duty cycle must be appropriate
2. Fan must turn when inverter is running
3. Pulse frequency (P1800) must be set to default value
4. Ambient temperature could be higher than specified for the inverter

Additional meaning for MM440 Frame size FX & GX:

- Fault value = 1: Rectifier overtemperature  
 = 2: Ambient overtemperature  
 = 3: EBOX overtemperature

**F0005 Inverter I<sup>2</sup>t OFF2****Possible Causes**

- Inverter overloaded
- Duty cycle too demanding
- Motor power (P0307) exceeds inverter power capability (r0206)

**Diagnose & Remedy**

Check the following:

1. Load duty cycle must lie within specified limits
2. Motor power (P0307) must match inverter power (r0206)

**F0011 Motor Over Temperature OFF1****Possible Causes**

Motor overloaded

**Diagnose & Remedy**

Check the following:

1. Load duty cycle must be correct
2. Motor nominal overtemperatures (P0626-P0628) must be correct
3. Motor temperature warning level (P0604) must match

If P0601 = 0 or 1, check the following:

1. Check if name plate data are correct (if not perform quick commissioning)
2. Accurate equivalent circuit data can be found by performing motor identification (P1910=1)
3. Check if motor weight (P0344) is reasonable. Change if necessary
4. Via P0626, P0627, P0628 the standard overtemperatures can be changed, if the motor is not a Siemens standard motor

If P0601 = 2, check the following:

1. Check if temperature shown in r0035 is reasonable
2. Check if the sensor is a KTY84 (other sensors are not supported)

**F0012 Inverter temp. signal lost OFF2****Possible Causes**

Wire breakage of inverter temperature (heatsink) sensor

|              |  |             |
|--------------|--|-------------|
| <b>F0015</b> | <b>Motor temperature signal lost</b>   | <b>OFF2</b> |
|              | <b>Possible Causes</b>   |             |
|              | Open or short circuit of motor temperature sensor. If signal loss is detected, temperature monitoring switches over to monitoring with the motor thermal model |             |
| <b>F0020</b> | <b>Mains Phase Missing</b>   | <b>OFF2</b> |
|              | <b>Possible Causes</b>   |             |
|              | Fault occurs if one of the three input phases are missed while the pulses are enabled and drive is loaded  |             |
|              | <b>Diagnose &amp; Remedy</b>   |             |
|              | Check the input wiring of the mains phases   |             |
| <b>F0021</b> | <b>Earth fault</b>   | <b>OFF2</b> |
|              | <b>Possible Causes</b>   |             |
|              | Fault occurs if the sum of the phase currents is higher than 5 % of the nominal inverter current   |             |
|              | <hr/>  |             |
|              | NOTE   |             |
|              | This fault only occurs on inverters that have 3 current sensors (Frame sizes D to F & FX, GX)  |             |
| <b>F0022</b> | <b>Powerstack fault</b>  | <b>OFF2</b> |
|              | <b>Possible Causes</b>   |             |
|              | That hardware fault (r0947 = 22 and r0949 = 1) caused by the following events:   |             |
|              | (1) DC-link overcurrent = short circuit of IGBT  |             |
|              | (2) Short circuit of chopper   |             |
|              | (3) Earth fault  |             |
|              | (4) I/O board is not properly inserted   |             |
|              | ➤ Frame sizes A to C (1),(2),(3),(4)   |             |
|              | ➤ Frame sizes D to E (1),(2),(4)   |             |
|              | ➤ Frame size F (2),(4)   |             |
|              | Since all these faults are assigned to one signal on the power stack, it is not possible to establish which one actually occurred.                             |             |
|              | MM440 Frame size FX & GX:  |             |
|              | ➤ UCE failure was detected, when r0947 = 22 and fault value r0949 = 12 or 13 or 14, depending on UCE.  |             |
|              | ➤ I2C bus read out error, when r0947 = 22 and fault value r0949 = 21 (The power has to be switched OFF/ON).  |             |
|              | <b>Diagnose &amp; Remedy</b>   |             |
|              | Check the I/O board. It has to be fully pressed home.  |             |
| <b>F0023</b> | <b>Output fault</b>  | <b>OFF2</b> |
|              | <b>Possible Causes</b>   |             |
|              | One motor phase is disconnected  |             |
| <b>F0030</b> | <b>Fan has failed</b>  | <b>OFF2</b> |
|              | <b>Possible Causes</b>   |             |
|              | Fan no longer working  |             |
|              | <b>Diagnose &amp; Remedy</b>   |             |
|              | 1. Fault cannot be masked while options module (AOP or BOP) is connected   |             |
|              | 2. Need a new fan  |             |
| <b>F0035</b> | <b>Auto restart after n</b>  | <b>OFF2</b> |
|              | <b>Possible Causes</b>   |             |
|              | Auto restart attempts exceed value of P1211  |             |

**F0041 Motor Data Identification Failure OFF2****Possible Causes**

Motor data identification failed.

Fault value = 0: Load missing

- 1: Current limit level reached during identification.
- 2: Identified stator resistance less than 0.1 % or greater than 100 %.
- 3: Identified rotor resistance less than 0.1 % or greater than 100 %.
- 4: Identified stator reactance less than 50 % and greater than 500 %
- 5: Identified main reactance less than 50 % and greater than 500 %
- 6: Identified rotor time constant less than 10 ms or greater than 5 s
- 7: Identified total leakage reactance less than 5 % and greater than 50 %
- 8: Identified stator leakage reactance less than 25 % and greater than 250 %
- 9: Identified rotor leakage inductance less than 25 % and greater than 250 %
- 20: Identified IGBT on-voltage less than 0.5 V or greater than 10 V
- 30: Current controller at voltage limit
- 40: Inconsistency of identified data set, at least one identification failed

Percentage values based on the impedance  $Z_b = V_{mot,nom} / \sqrt{3} / I_{mot,nom}$

**Diagnose & Remedy**

- Fault value = 0: Check that the motor is connected to the inverter
- Fault value = 1 - 40: Check if motor data in P0304 to P0311 are correct  
Check what type of motor wiring is required (star, delta).

**F0042 Speed Control Optimisation Failure OFF2****Possible Causes**

Speed control optimisation (P1960) failed

Fault value = 0: Time out waiting for stable speed

= 1: Inconsistent readings

**F0051 Parameter EEPROM Fault OFF2****Possible Causes**

Read or write failure while saving non-volatile parameter

**Diagnose & Remedy**

1. Factory Reset and new parameterization
2. Contact Customer Support / Service Department

**F0052 Power stack Fault OFF2****Possible Causes**

Read failure for power stack information or invalid data

**Diagnose & Remedy**

Hardware defect, contact Customer Support / Service Department

**F0053 IO EEPROM Fault OFF2****Possible Causes**

Read failure for IO EEPROM information or invalid data

**Diagnose & Remedy**

1. Check data
2. Change IO board

**F0054 Wrong IO Board OFF2****Possible Causes**

- Wrong IO board is connected
- No ID detected on IO board, no data

**Diagnose & Remedy**

1. Check data
2. Change IO board

|              |  |             |
|--------------|--|-------------|
| <b>F0060</b> | <b>Asic Timeout</b>  | <b>OFF2</b> |
|              | <b>Possible Causes</b><br>Internal communications failure  |             |
|              | <b>Diagnose &amp; Remedy</b><br>1. If fault persists, change inverter<br>2. Contact Service Department   |             |
| <b>F0070</b> | <b>CB setpoint fault</b>   | <b>OFF2</b> |
|              | <b>Possible Causes</b><br>No setpoint values from CB (communication board) during telegram off time  |             |
|              | <b>Diagnose &amp; Remedy</b><br>Check CB and communication partner   |             |
| <b>F0071</b> | <b>USS (BOP-link) setpoint fault</b>   | <b>OFF2</b> |
|              | <b>Possible Causes</b><br>No setpoint values from USS during telegram off time   |             |
|              | <b>Diagnose &amp; Remedy</b><br>Check USS master   |             |
| <b>F0072</b> | <b>USS (COMM link) setpoint fault</b>  | <b>OFF2</b> |
|              | <b>Possible Causes</b><br>No setpoint values from USS during telegram off time   |             |
|              | <b>Diagnose &amp; Remedy</b><br>Check USS master   |             |
| <b>F0080</b> | <b>ADC lost input signal</b>   | <b>OFF2</b> |
|              | <b>Possible Causes</b><br><ul style="list-style-type: none"> <li>➤ Broken wire</li> <li>➤ Signal out of limits</li> </ul>  |             |
| <b>F0085</b> | <b>External Fault</b>  | <b>OFF2</b> |
|              | <b>Possible Causes</b><br>External fault triggered via for example terminal inputs   |             |
|              | <b>Diagnose &amp; Remedy</b><br>Disable for example terminal input for fault trigger   |             |
| <b>F0090</b> | <b>Encoder feedback loss</b>   | <b>OFF2</b> |
|              | <b>Possible Causes</b><br>Signal from Encoder lost   |             |
|              | <b>Diagnose &amp; Remedy</b><br><ol style="list-style-type: none"> <li>1. Check encoder fitted. If encoder not fitted, set P0400 = 0 and select SLVC mode (P1300 = 20 or 22)</li> <li>2. If encoder fitted, check correct encoder selected (check encoder set-up in P0400).</li> <li>3. Check connections between encoder and inverter</li> <li>4. Check encoder not faulty (select P1300 = 0, run at fixed speed, check encoder feedback signal in r0061)</li> <li>5. Increase encoder loss threshold in P0492</li> </ol> |             |
| <b>F0101</b> | <b>Stack Overflow</b>  | <b>OFF2</b> |
|              | <b>Possible Causes</b><br>Software error or processor failure  |             |
|              | <b>Diagnose &amp; Remedy</b><br>Run self test routines   |             |



**F0221 PID Feedback below min. value OFF2****Possible Causes**

PID Feedback below min. value P2268

**Diagnose & Remedy**

1. Change value of P2268
2. Adjust feedback gain

**F0222 PID Feedback above max. value OFF2****Possible Causes**

PID feedback above max. value P2267

**Diagnose & Remedy**

1. Change value of P2267
2. Adjust feedback gain

**F0450 BIST Tests Failure OFF2****Possible Causes**

Fault value = 1: Some power section tests have failed  
 2: Some control board tests have failed  
 4: Some functional tests have failed  
 8: Some IO board tests have failed (MM 420 only)  
 16: Internal RAM failed on power-up check

**Diagnose & Remedy**

Hardware defect, contact Customer Support / Service Department

**F0452 Belt Failure Detected OFF2****Possible Causes**

Load conditions on motor indicate belt failure or mechanical fault.

**Diagnose & Remedy**

Check the following:

1. No breakage, seizure or obstruction of drive train.
2. If using an external speed sensor, check for correct function. Check parameters:
  - P2192 (delay time for permitted deviation)
3. If using the torque envelope, check parameters:
  - P2182 (threshold frequency f1)
  - P2183 (threshold frequency f2)
  - P2184 (threshold frequency f3)
  - P2185 (upper torque threshold 1)
  - P2186 (lower torque threshold 1)
  - P2187 (upper torque threshold 2)
  - P2188 (lower torque threshold 2)
  - P2189 (upper torque threshold 3)
  - P2190 (lower torque threshold 3)
  - P2192 (delay time for permitted deviation)

## 6.4 Alarm Messages

Alarm messages are stored in parameter r2110 under their code number (e.g. A0503 = 503) and can be read out from there.

### A0501 Current Limit

#### Possible Causes

- Motor power (P0307) does not correspond to the inverter power (P0206)
- Motor leads are too long
- Earth faults

#### Diagnose & Remedy

Check the following:

1. Motor power (P0307) must correspond to inverter power (r0206)
  2. Cable length limits must not be exceeded
  3. Motor cable and motor must have no short-circuits or earth faults
  4. Motor parameters must match the motor in use
  5. Value of stator resistance (P0350) must be correct
  6. Motor must not be obstructed or overloaded
- Increase the ramp-up-time.
  - Reduce the boost level (V/f control: P1311 & P1312)

### A0502 Overvoltage limit

#### Possible Causes

- Overvoltage limit is reached
- This warning can occur during ramp down, if the dc-link controller is disabled (P1240 = 0)

#### Diagnose & Remedy

Check the following:

1. Supply voltage (P0210) must lie within limits indicated on rating plate
2. DC-link voltage controller must be enabled (P1240) and parameterized properly
3. Ramp-down time (P1121) must match inertia of load
4. Required braking power must lie within specified limits

### A0503 UnderVoltage Limit

#### Possible Causes

- Main supply failed
- Main supply (P0210) and consequently DC-link voltage (r0026) below specified limit (P2172)

#### Diagnose & Remedy

1. Supply voltage (P0210) must lie within limits indicated on rating plate
  2. Supply must not be susceptible to temporary failures or voltage reductions
- Enable kinetic buffering (P1240 = 2)

### A0504 Inverter OverTemperature

#### Possible Causes

Warning level of inverter heat-sink temperature (P0614) is exceeded, resulting in pulse frequency reduction and/or output frequency reduction (depending on parameterization in P0610)

#### Diagnose & Remedy

Check the following:

1. Load conditions and duty cycle must be appropriate
2. Fan must turn when inverter is running
3. Pulse frequency (P1800) must be set to default value
4. Ambient temperature could be higher than specified for the inverter

**A0505 Inverter I<sup>2</sup>t****Possible Causes**

Warning level (P0294) exceeded, output frequency and/or pulse frequency will be reduced if parameterized (P0290)

**Diagnose & Remedy**

Check the following:

1. Load duty cycle must lie within specified limits
2. Motor power (P0307) must match inverter power (r0206)

**A0511 Motor OverTemperature****Possible Causes**

- Motor overloaded
- Load duty cycle too high

**Diagnose & Remedy**

Independently of the kind of temperature determination check the following:

1. Load duty cycle must be correct
2. Motor nominal overtemperatures (P0626-P0628) must be correct
3. Motor temperature warning level (P0604) must match

If P0601 = 0 or 1, check the following:

1. Check if name plate data are correct (if not perform quick commissioning)
2. Accurate equivalent circuit data can be found by performing motor identification (P1910=1)
3. Check if motor weight (P0344) is reasonable. Change if necessary
4. Via P0626, P0627, P0628 the standard overtemperatures can be changed, if the motor is not a Siemens standard motor

If P0601 = 2, check the following:

1. Check if temperature shown in r0035 is reasonable
2. Check if the sensor is a KTY84 (other sensors are not supported)

**A0522 I2C read out timeout****Possible Causes**

The cyclic access to the UCE Values and powerstack temperatures via the I2C bus (MM440 Frame size FX & GX) is disturbed

**A0523 Output fault****Possible Causes**

One motor phase is disconnected

**A0535 Braking Resistor Hot****Diagnose & Remedy**

- Increase duty cycle P1237
- Increase ramp down time P1121

**A0541 Motor Data Identification Active****Possible Causes**

Motor data identification (P1910) selected or running

**A0542 Speed Control Optimisation Active****Possible Causes**

Speed Control Optimisation (P1960) is selected or running

**A0590 Encoder feedback loss warning****Possible Causes**

Signal from Encoder lost and Inverter has switched to sensorless vector control

**Diagnose & Remedy**

Stop inverter and then

1. Check encoder fitted. If encoder not fitted, set P0400 = 0 and select SLVC mode (P1300 = 20 or 22)
2. If encoder fitted, check correct encoder selected (check encoder set-up in P0400).
3. Check connections between encoder and inverter
4. Check encoder not faulty (select P1300 = 0, run at fixed speed, check encoder feedback signal in r0061)
5. Increase encoder loss threshold in P0492

**A0600 RTOS Overrun Warning****A0700 CB warning 1****Possible Causes**

CB (communication board) specific

**Diagnose & Remedy**

See CB user manual

**A0701 CB warning 2****Possible Causes**

CB (communication board) specific

**Diagnose & Remedy**

See CB user manual

**A0702 CB warning 3****Possible Causes**

CB (communication board) specific

**Diagnose & Remedy**

See CB user manual

**A0703 CB warning 4****Possible Causes**

CB (communication board) specific

**Diagnose & Remedy**

See CB user manual

**A0704 CB warning 5****Possible Causes**

CB (communication board) specific

**Diagnose & Remedy**

See CB user manual

**A0705 CB warning 6****Possible Causes**

CB (communication board) specific

**Diagnose & Remedy**

See CB user manual

**A0706 CB warning 7****Possible Causes**

CB (communication board) specific

**Diagnose & Remedy**

See CB user manual

**A0707 CB warning 8****Possible Causes**

CB (communication board) specific

**Diagnose & Remedy**

See CB user manual

**A0708 CB warning 9****Possible Causes**

CB (communication board) specific

**Diagnose & Remedy**

See CB user manual

**A0709 CB warning 10****Possible Causes**

CB (communication board) specific

**Diagnose & Remedy**

See CB user manual

**A0710 CB communication error****Possible Causes**

Communication with CB (communication board) is lost

**Diagnose & Remedy**

Check CB hardware

**A0711 CB configuration error****Possible Causes**

CB (communication board) reports a configuration error.

**Diagnose & Remedy**

Check CB parameters

**A0910 Vdc-max controller de-activated****Possible Causes**

Vdc max controller has been de-activated, since controller is not capable of keeping DC-link voltage (r0026) within limits (P2172).

- Occurs if main supply voltage (P0210) is permanently too high
- Occurs if motor is driven by an active load, causing motor to go into regenerative mode
- Occurs at very high load inertias, when ramping down

**Diagnose & Remedy**

Check the following:

1. Input voltage (P0210) must lie within range
2. Load must be match

**A0911 Vdc-max controller active****Possible Causes**

Vdc max controller is active; so ramp-down times will be increased automatically to keep DC-link voltage (r0026) within limits (P2172).

**A0912 Vdc-min controller active****Possible Causes**

Vdc min controller will be activated if DC-link voltage (r0026) falls below minimum level (P2172).

The kinetic energy of the motor is used to buffer the DC-link voltage, thus causing deceleration of the drive!

So short mains failures do not necessarily lead to an undervoltage trip.

**A0920 ADC parameters not set properly****Possible Causes**

ADC parameters should not be set to identical values, since this would produce illogical results.

Fault value = 0: Parameter settings for output identical

1: Parameter settings for input identical

2: Parameter settings for input do not correspond to ADC type

**A0921 DAC parameters not set properly****Possible Causes**

DAC parameters should not be set to identical values, since this would produce illogical results.

Fault value = 0: Parameter settings for output identical

1: Parameter settings for input identical

2: Parameter settings for output do not correspond to DAC type

**A0922 No load applied to inverter****Possible Causes**

No Load is applied to the inverter.

As a result, some functions may not work as under normal load conditions.

**A0923 Both JOG Left and JOG Right are requested****Possible Causes**

Both JOG right and JOG left (P1055/P1056) have been requested. This freezes the RFG output frequency at its current value.

**A0936 PID Autotuning Active****Possible Causes**

PID Autotuning (P2350) selected or running

**A0952 Belt Failure Warning****Possible Causes**

Load conditions on motor indicate belt failure or mechanical fault.

**Diagnose & Remedy**

Check the following:

1. No breakage, seizure or obstruction of drive train.
2. If using an external speed sensor, check for correct function. Check parameters:
  - P2192 (delay time for permitted deviation)
3. If using the torque envelope, check parameters:
  - P2182 (threshold frequency f1)
  - P2183 (threshold frequency f2)
  - P2184 (threshold frequency f3)
  - P2185 (upper torque threshold 1)
  - P2186 (lower torque threshold 1)
  - P2187 (upper torque threshold 2)
  - P2188 (lower torque threshold 2)
  - P2189 (upper torque threshold 3)
  - P2190 (lower torque threshold 3)
  - P2192 (delay time for permitted deviation)

## 7 MICROMASTER 430 specifications

### **This Chapter contains:**

- Table 7.1 contains the general technical specifications for the MICROMASTER 430 inverter
- Table 7-2 contains terminal tightening torques
- Table 7-3 contains current values depending on pulse frequency
- Table 7-3 includes various tables of specific technical data for individual MICROMASTER 430 inverters

Table 7-1 MICROMASTER 430 Performance Ratings

| Feature                                      | Specification  |
|--|--|
| Mains Operating Voltage & Power Ranges       | VT 3 AC 380 to 480 V $\pm$ 10 %      7.50 kW – 90.0 kW (10.0 hp – 120 hp)  |
| Input Frequency                              | 47 to 63 Hz  |
| Output frequency                             | 0 Hz to 650 Hz   |
| Power Factor                                 | $\geq$ 0.7   |
| Inverter Efficiency                          | Frame Sizes C to F:      96 % to 97 %<br>Frame Sizes FX and GX:      97 % to 98 %  |
| Overload Capability for variable torque (VT) | Frame Sizes C to F:      1.1 x Nominal output current (i.e. 110 % overload) for 60 s every 300 s and 1.4 x Nominal output current (i.e. 140 % overload) for 3 s every 300 s<br>Frame Sizes FX and GX:      1.1 x Nominal output current (i.e. 110% overload) for 59 s every 300 s and 1.5 x Nominal output current (i.e. 150% overload) for 1 s every 300s |
| Inrush Current                               | Less than rated input current  |
| Control Method                               | Linear V/f control, Linear V/f control with FCC, Parabolic V/f control, Multi-point V/f control, V/f control for textile applications, V/f control with FCC for textile applications, V/f control with independent voltage setpoint  |
| Pulse Frequency                              | Frame Sizes C to F:      2 kHz to 8 kHz (2 kHz steps)<br>Frame Sizes FX and GX:      2 kHz to 8 kHz (2 kHz steps) (Standard 2 kHz (VT), power reduction see Table 7-3)   |
| Fixed Frequencies                            | 15, programmable   |
| Skip Frequencies                             | 4, programmable  |
| Setpoint Resolution                          | 0.01 Hz Digital, 0.01 Hz Serial, 10 bit Analogue (motor potentiometer 0.1 Hz [0.1% (in PID mode)])   |
| Digital Inputs                               | 6, programmable (isolated), switchable active high / active low (PNP/NPN)  |
| Analog Input 1                               | 0 - 10 V, 0 - 20 mA and -10 V to +10 V   |
| Analog Input 2                               | 0 - 10 V and 0 - 20 mA   |
| Relay Outputs                                | 3, programmable 30 V DC / 5 A (resistive), 250 V AC 2 A (inductive)  |
| Analogue Output                              | 2, programmable (0 to 20 mA)   |
| Serial Interface                             | RS-485, optional RS-232  |
| Electromagnetic Compatibility                | Frame Sizes C to F:      Optional EMC filters to EN 55011 Class A or B, also Internal Class A filters available<br>Frame Sizes FX and GX:      With EMI filter (available as an option) the limiting values of the EN 55011, Class A are fulfilled for conducted emission (line commutating choke required).   |
| Braking                                      | DC braking, Compound braking   |
| Protection Level                             | IP20   |
| Temperature range (VT)                       | Frame Sizes C to F:      -10 °C to +40 °C (14 °F to 104 °F)<br>Frame Sizes FX and GX:      0 °C to +40 °C (32 °F to 104 °F), to 55 °C (131 °F)<br>Power reduction see Figure 2-2   |
| Storage Temperature                          | -40 °C to +70 °C (40 °F to 158 °F)   |
| Humidity                                     | < 95 % RH – non-condensing   |



|                       |  |
|-----------------------|--|
| Operational Altitudes | Frame Sizes C to F: Up to 1000 m above sea level without derating<br>Frame Sizes FX and GX: Up to 2000 m above sea level without derating  |
| Protection Features   | Undervoltage, Overvoltage, Overload, Ground Faults, Short circuit, Stall Prevention, Motor Blocking Protection, Motor Overtemperature, Inverter Overtemperature, Parameter Interlock |
|                       | Frame Sizes C to F: UL, cUL, CE, C-tick<br>Frame Sizes FX and GX: UL (in preparation), cUL (in preparation), CE  |
| CE Marked             | Conformity with EC Low Voltage Directive 73/23/EEC and Electromagnetic Compatibility Directive 89/336/EEC  |

Table 7-2 Tightening torques for power terminals

| Frame Size | Tightening Torque [Nm] | Frame Size | Tightening Torque [Nm] |
|------------|------------------------|------------|------------------------|
| C          | 2,25                   | F          | 50                     |
| D          | 10 (max.)              | FX         | 25                     |
| E          | 10 (max.)              | GX         | 25                     |

Table 7-3 Current reduction depending on pulse frequency

| Mains voltage | Power [kW] | Output current in A with a switching frequency of; |       |       |        |        |        |        |
|---------------|------------|--|-------|-------|--------|--------|--------|--------|
|               |            | 4 kHz  | 6 kHz | 8 kHz | 10 kHz | 12 kHz | 14 kHz | 16 kHz |
| 3 AC 400 V    | 7,5        | 13,2   | 11,9  | 10,6  | 9,2    | 7,9    | 6,6    | 5,3    |
|               | 11,0       | 19,0   | 18,1  | 17,1  | 15,2   | 13,3   | 11,4   | 9,5    |
|               | 15,0       | 26,0   | 23,4  | 20,8  | 18,2   | 15,6   | 13,0   | 10,4   |
|               | 18,5       | 32,0   | 30,4  | 28,8  | 25,6   | 22,4   | 19,2   | 16,0   |
|               | 22         | 38,0   | 34,2  | 30,4  | 26,6   | 22,8   | 19,0   | 15,2   |
|               | 30         | 45,0   | 40,5  | 36,0  | 31,5   | 27,0   | 22,5   | 18,0   |
|               | 37         | 62,0   | 58,9  | 55,8  | 49,6   | 43,4   | 37,2   | 31,0   |
|               | 45         | 75,0   | 67,5  | 60,0  | 52,5   | 45,0   | 37,5   | 30,0   |
|               | 55         | 90,0   | 76,5  | 63,0  | 51,8   | 40,5   | 33,8   | 27,0   |
|               | 75         | 110,0  | 93,5  | 77,0  | 63,3   | 49,5   | 41,3   | 33,0   |
|               | 90         | 145,0  | 112,4 | 79,8  | 68,9   | 58,0   | 50,8   | 43,5   |
|               | 110        | 178,0  | -     | -     | -      | -      | -      | -      |
|               | 132        | 205,0  | -     | -     | -      | -      | -      | -      |
|               | 160        | 250,0  | -     | -     | -      | -      | -      | -      |
| 200           | 302,0      | -  | -     | -     | -      | -      | -      |        |
| 250           | 370,0      | -  | -     | -     | -      | -      | -      |        |

Table 7-4 MICROMASTER 430 Specifications

In order to have a UL compliant installation fuses from the SITOR range with the appropriate current rating must be used.

Input voltage range **3 AC 380 V – 480 V, ± 10 %**  
(with built in Class A Filter), Part 1

| Order No.                             | 6SE6430-           | 2AD27-5CA0  | 2AD31-1CA0   | 2AD31-5CA0   | 2AD31-8DA0   | 2AD32-2DA0   |
|---------------------------------------|--------------------|-------------|--------------|--------------|--------------|--------------|
| VT Motor Output Rating                | [kW]<br>[hp]       | 7.5<br>10.0 | 11.0<br>15.0 | 15.0<br>20.0 | 18.5<br>25.0 | 22.0<br>30.0 |
| Output Power                          | [kVA]              | 10.1        | 14.0         | 19.8         | 24.4         | 29.0         |
| VT Input Current                      | [A]                | 16.0        | 22.5         | 30.5         | 37.2         | 43.3         |
| VT Output Cur. Max.                   | [A]                | 18.4        | 26.0         | 32.0         | 38.0         | 45.0         |
| Recommended Fuse                      | [A]                | 20          | 32           | 35           | 50           | 63           |
|                                       | 3NA                | 3007        | 3012         | 3014         | 3020         | 3022         |
| Fuses recommended for UL applications | [A]                |             |              |              | 50           | 63           |
|                                       | 3NE                |             |              |              | 1817-0       | 1818-0       |
| Input Cable Min.                      | [mm <sup>2</sup> ] | 2.5         | 4.0          | 6.0          | 10.0         | 10.0         |
|                                       | [awg]              | 13          | 11           | 9            | 7            | 7            |
| Input Cable Max.                      | [mm <sup>2</sup> ] | 10.0        | 10.0         | 10.0         | 35.0         | 35.0         |
|                                       | [awg]              | 7           | 7            | 7            | 2            | 2            |
| Output Cable Min.                     | [mm <sup>2</sup> ] | 2.5         | 4.0          | 6.0          | 10.0         | 10.0         |
|                                       | [awg]              | 13          | 11           | 9            | 7            | 7            |
| Output Cable Max.                     | [mm <sup>2</sup> ] | 10.0        | 10.0         | 10.0         | 35.0         | 35.0         |
|                                       | [awg]              | 7           | 7            | 7            | 2            | 2            |
| Weight                                | [kg]               | 5.7         | 5.7          | 5.7          | 17.0         | 17.0         |
|                                       | [lbs]              | 12.5        | 12.5         | 12.5         | 37.0         | 37.0         |
| Dimensions                            | w [mm]             | 185.0       | 185.0        |              | 275.0        | 275.0        |
|                                       | h [mm]             | 245.0       | 245.0        | 245.0        | 520.0        | 520.0        |
|                                       | d [mm]             | 195.0       | 195.0        | 195.0        | 245.0        | 245.0        |
|                                       | w [inches]         | 7.28        | 7.28         | 7.28         | 10.83        | 10.83        |
|                                       | h [inches]         | 9.65        | 9.65         | 9.65         | 20.47        | 20.47        |
|                                       | d [inches]         | 7.68        | 7.68         | 7.68         | 9.65         | 9.65         |

Input voltage range  
(with built in Class A Filter), Part 2

3 AC 380 V – 480 V, ± 10 %

| Order No.                             | 6SE6430-           | 2AD33-0DA0   | 2AD33-7EA0   | 2AD34-5EA0   | 2AD35-5FA0   | 2AD37-5FA0    | 2AD38-8FA0    |
|---------------------------------------|--------------------|--------------|--------------|--------------|--------------|---------------|---------------|
| VT Motor Output Rating                | [kW]<br>[hp]       | 30.0<br>40.0 | 37.0<br>50.0 | 45.0<br>60.0 | 55.0<br>75.0 | 75.0<br>100.0 | 90.0<br>120.0 |
| Output Power                          | [kVA]              | 34.3         | 47.3         | 57.2         | 68.6         | 83.8          | 110.5         |
| VT Input Current                      | [A]                | 59.3         | 71.7         | 86.6         | 103.6        | 138.5         | 168.5         |
| VT Output Cur. Max.                   | [A]                | 62.0         | 75.0         | 90.0         | 110.0        | 145.0         | 178.0         |
| Recommended Fuse                      | [A]                | 80           | 100          | 125          | 160          | 160           | 200           |
|                                       | 3NA                | 3024         | 3030         | 3032         | 3036         | 3036          | 3140          |
| Fuses recommended for UL applications | [A]                | 80           | 100          | 125          | 160          | 200           | 200           |
|                                       | 3NE                | 1820-0       | 1021-0       | 1022-0       | 1224-0       | 1225-0        | 1225-0        |
| Input Cable Min.                      | [mm <sup>2</sup> ] | 16.0         | 25.0         | 25.0         | 35.0         | 70.0          | 70.0          |
|                                       | [awg]              | 5            | 3            | 3            | 2            | -2            | -2            |
| Input Cable Max.                      | [mm <sup>2</sup> ] | 35.0         | 35.0         | 35.0         | 150.0        | 150.0         | 150.0         |
|                                       | [awg]              | 2            | 2            | 2            | -5           | -5            | -5            |
| Output Cable Min.                     | [mm <sup>2</sup> ] | 16.0         | 25.0         | 25.0         | 50.0         | 70.0          | 95.0          |
|                                       | [awg]              | 5            | 3            | 3            | 0            | -2            | -3            |
| Output Cable Max.                     | [mm <sup>2</sup> ] | 35.0         | 35.0         | 35.0         | 150.0        | 150.0         | 150.0         |
|                                       | [awg]              | 2            | 2            | 2            | -5           | -5            | -5            |
| Weight                                | [kg]               | 17.0         | 22.0         | 22.0         | 75.0         | 75.0          | 75.0          |
|                                       | [lbs]              | 37.0         | 48.0         | 48.0         | 165.0        | 165.0         | 165.0         |
| Dimensions                            | w [mm]             | 275.0        | 275.0        | 275.0        | 350.0        | 350.0         | 350.0         |
|                                       | h [mm]             | 520.0        | 650.0        | 650.0        | 1150.0       | 1150.0        | 1150.0        |
|                                       | d [mm]             | 245.0        | 245.0        | 245.0        | 320.0        | 320.0         | 320.0         |
|                                       | w [inches]         | 10.83        | 10.83        | 10.83        | 13.78        | 13.78         | 13.78         |
|                                       | h [inches]         | 20.47        | 25.59        | 25.59        | 45.28        | 45.28         | 45.28         |
|                                       | d [inches]         | 9.65         | 9.65         | 9.65         | 12.6         | 12.6          | 12.6          |

**Input voltage range 3 AC 380 V – 480 V, ± 10 % (Unfiltered), Part 1**

| Order No.                             | 6SE6430<br>-       | 2UD27-<br>5CA0 | 2UD31-<br>1CA0 | 2UD31-<br>5CA0 | 2UD31-<br>8DA0 | 2UD32-<br>2DA0 |
|---------------------------------------|--------------------|----------------|----------------|----------------|----------------|----------------|
| VT Motor Output Rating                | [kW]<br>[hp]       | 7.5<br>10.0    | 11.0<br>15.0   | 15.0<br>20.0   | 18.5<br>25.0   | 22.0<br>30.0   |
| Output Power                          | [kVA]              | 10.1           | 14.0           | 19.8           | 24.4           | 29.0           |
| VT Input Current                      | [A]                | 16.0           | 22.5           | 30.5           | 37.2           | 43.3           |
| VT Output Cur. Max.                   | [A]                | 18.4           | 26.0           | 32.0           | 38.0           | 45.0           |
| Recommended Fuse                      | [A]                | 20             | 32             | 35             | 50             | 63             |
|                                       | 3NA                | 3007           | 3012           | 3014           | 3020           | 3022           |
| Fuses recommended for UL applications | [A]                |                |                |                | 50             | 63             |
|                                       | 3NE                |                |                |                | 1817-0         | 1818-0         |
| Input Cable Min.                      | [mm <sup>2</sup> ] | 2.5            | 4.0            | 6.0            | 10.0           | 10.0           |
|                                       | [awg]              | 13             | 11             | 9              | 7              | 7              |
| Input Cable Max.                      | [mm <sup>2</sup> ] | 10.0           | 10.0           | 10.0           | 35.0           | 35.0           |
|                                       | [awg]              | 7              | 7              | 7              | 2              | 2              |
| Output Cable Min.                     | [mm <sup>2</sup> ] | 2.5            | 4.0            | 6.0            | 10.0           | 10.0           |
|                                       | [awg]              | 13             | 11             | 9              | 7              | 7              |
| Output Cable Max.                     | [mm <sup>2</sup> ] | 10.0           | 10.0           | 10.0           | 35.0           | 35.0           |
|                                       | [awg]              | 7              | 7              | 7              | 2              | 2              |
| Weight                                | [kg]               | 5.5            | 5.5            | 5.5            | 16.0           | 16.0           |
|                                       | [lbs]              | 12.1           | 12.1           | 12.1           | 35.0           | 35.0           |
| Dimensions                            | w [mm]             | 185.0          | 185.0          | 185.0          | 275.0          | 275.0          |
|                                       | h [mm]             | 245.0          | 245.0          | 245.0          | 520.0          | 520.0          |
|                                       | d [mm]             | 195.0          | 195.0          | 195.0          | 245.0          | 245.0          |
|                                       | w [inches]         | 7.28           | 7.28           | 7.28           | 10.83          | 10.83          |
|                                       | h [inches]         | 9.65           | 9.65           | 9.65           | 20.47          | 20.47          |
|                                       | d [inches]         | 7.68           | 7.68           | 7.68           | 9.65           | 9.65           |

**Input voltage range 3 AC 380 V – 480 V, ± 10 % (Unfiltered), Part 2**

| Order No.                             | 6SE6430-           | 2UD33-0DA0 | 2UD33-7EA0 | 2UD34-5EA0 | 2UD35-5FA0 | 2UD37-5FA0 | 2UD38-8FA0 |
|---------------------------------------|--------------------|------------|------------|------------|------------|------------|------------|
| VT Motor Output Rating                | [kW]               | 30.0       | 37.0       | 45.0       | 55.0       | 75.0       | 90.0       |
|                                       | [hp]               | 40.0       | 50.0       | 60.0       | 75.0       | 100.0      | 120.0      |
| Output Power                          | [kVA]              | 34.3       | 47.3       | 57.2       | 68.6       | 83.8       | 110.5      |
| VT Input Current                      | [A]                | 59.3       | 71.7       | 86.6       | 103.6      | 138.5      | 168.5      |
| VT Output Cur. Max.                   | [A]                | 62.0       | 75.0       | 90.0       | 110.0      | 145.0      | 178.0      |
| Recommended Fuse                      | [A]                | 80         | 100        | 125        | 160        | 160        | 200        |
|                                       | 3NA                | 3024       | 3030       | 3032       | 3036       | 3036       | 3140       |
| Fuses recommended for UL applications | [A]                | 80         | 100        | 125        | 160        | 200        | 200        |
|                                       | 3NE                | 1820-0     | 1021-0     | 1022-0     | 1224-0     | 1225-0     | 1225-0     |
| Input Cable Min.                      | [mm <sup>2</sup> ] | 16.0       | 25.0       | 25.0       | 35.0       | 70.0       | 70.0       |
|                                       | [awg]              | 5          | 3          | 3          | 2          | -2         | -2         |
| Input Cable Max.                      | [mm <sup>2</sup> ] | 35.0       | 35.0       | 35.0       | 150.0      | 150.0      | 150.0      |
|                                       | [awg]              | 2          | 2          | 2          | -5         | -5         | -5         |
| Output Cable Min.                     | [mm <sup>2</sup> ] | 16.0       | 25.0       | 25.0       | 35.0       | 70.0       | 95.0       |
|                                       | [awg]              | 5          | 3          | 3          | 2          | -2         | -3         |
| Output Cable Max.                     | [mm <sup>2</sup> ] | 35.0       | 35.0       | 35.0       | 150.0      | 150.0      | 150.0      |
|                                       | [awg]              | 2          | 2          | 2          | -5         | -5         | -5         |
| Weight                                | [kg]               | 16.0       | 20.0       | 20.0       | 56.0       | 56.0       | 56.0       |
|                                       | [lbs]              | 35.0       | 44.0       | 44.0       | 123.0      | 123.0      | 123.0      |
| Dimensions                            | w [mm]             | 275.0      | 275.0      | 275.0      | 350.0      | 350.0      | 350.0      |
|                                       | h [mm]             | 520.0      | 650.0      | 650.0      | 850.0      | 850.0      | 850.0      |
|                                       | d [mm]             | 245.0      | 245.0      | 245.0      | 320.0      | 320.0      | 320.0      |
|                                       | w [inches]         | 10.83      | 10.83      | 10.83      | 13.78      | 13.78      | 13.78      |
|                                       | h [inches]         | 20.47      | 25.59      | 25.59      | 33.46      | 33.46      | 33.46      |
|                                       | d [inches]         | 9.65       | 9.65       | 9.65       | 12.6       | 12.6       | 12.6       |

**Input voltage range 3 AC 380 V – 480 V, ± 10 % (Unfiltered), Part 3**

| Order No.                      | 6SE6430-                 | 2UD41-1FA0            | 2UD41-3FA0            | 2UD41-6GA0 | 2UD42-0GA0 | 2UD42-5GA0 |
|--------------------------------|--------------------------|-----------------------|-----------------------|------------|------------|------------|
| VT Motor Output Rating         | [kW]                     | 110                   | 132                   | 160        | 200        | 250        |
|                                | [hp]                     | 150                   | 200                   | 250        | 300        | 333        |
| Output Power                   | [kVA]                    | 145,4                 | 180                   | 214,8      | 263,2      | 339,4      |
| VT Input Current               | [A]                      | 200                   | 245                   | 297        | 354        | 442        |
| VT Output Cur. Max.            | [A]                      | 205,0                 | 250,0                 | 302,0      | 370,0      | 477,0      |
| Recommended Fuse               | [A]                      | 250                   | 315                   | 400        | 450        | 560        |
|                                |                          | 3NE1227-0             | 3NE1230-0             | 3NE1332-0  | 3NE1333-0  | 3NE1435-0  |
| Required cooling air flow rate | l/s                      | 225                   | 225                   | 440        | 440        | 440        |
| Pipe cable shoe to DIN 46235   | [mm]                     | 10                    | 10                    | 10         | 10         | 10         |
| Max. wire cross section        | [mm <sup>2</sup> ]       | 1 x 185 or<br>2 x 120 | 1 x 185 or<br>2 x 120 | 2 x 240    | 2 x 240    | 2 x 240    |
|                                | [AWG]<br>bzw.<br>[kcmil] | 1 x 350 or<br>2 x 4/0 | 1 x 350 or<br>2 x 4/0 | 2 x 400    | 2 x 400    | 2 x 400    |
| Weight                         | [kg]                     | 110                   | 110                   | 190        | 190        | 190        |
|                                | [lbs]                    | 242                   | 242                   | 418        | 418        | 418        |
| Dimensions                     | w [mm]                   | 326                   | 326                   | 326        | 326        | 326        |
|                                | h [mm]                   | 1400                  | 1400                  | 1533       | 1533       | 1533       |
|                                | d [mm]                   | 356                   | 356                   | 545        | 545        | 545        |
|                                | w [inches]               | 12,80                 | 12,80                 | 12,80      | 12,80      | 12,80      |
| h [inches]                     | 55,12                    | 55,12                 | 60,35                 | 60,35      | 60,35      |            |
| d [inches]                     | 12,83                    | 12,83                 | 21,46                 | 21,46      | 21,46      |            |

## 8 Options

An overview of the options available for the MICROMASTER 430 is given in this section. For further information about options, please refer to the catalog or the documentation CD.

### 8.1 Device-independent options

- Basic Operator Panel 2 (BOP-2)
- PROFIBUS module
- PC to inverter connection kit
- PC connection kit
- BOP/AOP door mounting kit for single inverter control
- "DriveMonitor" and "Starter" commissioning tool

### 8.2 Device-dependent options

#### Frame Sizes C to F

- EMC filter, Class A
- EMC filter, Class B (Frame size C)
- Line commutating choke
- Output choke
- Gland plate

#### Frame Sizes FX and GX

- Line commutating choke
- EMC filter, Class A (power commutating choke required)





## 9 Electro-magnetic compatibility (EMC)

**This Chapter contains:**

EMC information.

|     |                                      |     |
|-----|--------------------------------------|-----|
| 9.1 | Electro-magnetic compatibility ..... | 114 |
|-----|--------------------------------------|-----|

## 9.1 Electro-magnetic compatibility

(EMC) All manufacturers / assemblers of electrical apparatus which “performs a complete intrinsic function and is placed on the market as a single unit intended for the end user” must comply with the EMC directive 89/336/EEC.

There are three routes for the manufacturer/assembler to demonstrate compliance:

### 9.1.1 Self-certification

This is a manufacturer's declaration that the European standards applicable to the electrical environment for which the apparatus is intended have been met. Only standards that have been officially published in the Official Journal of the European Community can be cited in the manufacturer's declaration.

### 9.1.2 Technical construction file

A technical construction file can be prepared for the apparatus describing its EMC characteristics. This file must be approved by a ‘Competent Body’ appointed by the appropriate European government organization. This approach allows the use of standards that are still in preparation.

### 9.1.3 EC type examination certificate

This approach is only applicable to radio communication transmitting apparatus. All MICROMASTER units are certified for compliance with the EMC directive, when installed in accordance with the recommendations in Section 2.

### 9.1.4 EMC Directive Compliance with Imminent Harmonics Regulations

Since 1st January 2001 all electrical apparatus covered by the EMC Directive will have to comply with EN 61000-3-2 "Limits for harmonic current emissions (equipment input  $\leq 16$  A per phase)".

All Siemens variable speed drives of the MICROMASTER, MIDIMASTER, MICROMASTER Eco and COMBIMASTER ranges, which are classified as "Professional Equipment" within the terms of the standard, fulfill the requirements of the standard.

The allowed harmonic currents for “professional equipment” with an input power  $> 1$  kW are not yet defined. Therefore, any electrical apparatus containing the above drives which has an input power  $> 1$  kW will not require connection approval.

### 9.1.5 Classification of EMC performance

Three General classes of EMC performance are available as detailed below:

#### Class 1: General Industrial

Compliance with the EMC Product Standard for Power Drive Systems EN 68100-3 for use in **Second Environment (Industrial)** and **Restricted Distribution**.

Table 9-1 General Industrial  
(unfiltered inverters together with approved external mains filter)

| EMC Phenomenon    |                                       | Standard                      | Level                           |
|-------------------|---------------------------------------|-------------------------------|---------------------------------|
| <b>Emissions:</b> | Radiated Emissions                    | Frame Sizes C to F EN 55011   | Level A1                        |
|                   |                                       | Frame Sizes FX, GX EN 68100-3 | Second Environment              |
|                   | Conducted Emissions                   | Frame Sizes C to F EN 55011   | Level A1                        |
|                   |                                       | Frame Sizes FX, GX EN 68100-3 | Second Environment              |
| <b>Immunity:</b>  | Electrostatic Discharge               | EN 61000-4-2                  | 8 kV air discharge              |
|                   | Burst Interference                    | EN 61000-4-4                  | 2 kV power cables, 1 kV control |
|                   | Radio Frequency Electromagnetic Field | IEC 1000-4-3                  | 26-1000 MHz, 10 V/m             |

**Class 2: Filtered Industrial**

This level of performance will allow the manufacturer/assembler to self-certify their apparatus for compliance with the EMC directive for the industrial environment as regards the EMC performance characteristics of the power drive system. Performance limits are as specified in the Generic Industrial Emissions and Immunity standards EN 50081-2 and EN 50082-2.

Table 9-2 Filtered Industrial

| EMC Phenomenon    |   | Standard            | Level  |
|-------------------|---|---------------------|--|
| <b>Emissions:</b> | Radiated Emissions  | EN 55011            | Limit A1   |
|                   | Conducted Emissions   | EN 55011            | Limit A1   |
| <b>Immunity:</b>  | Supply Voltage Distortion                                   | IEC 1000-2-4 (1993) |  |
|                   | Voltage Fluctuations, Dips, Unbalance, Frequency Variations | IEC 1000-2-1        |  |
|                   | Magnetic Fields   | EN 61000-4-8        | 50 Hz, 30 A/m  |
|                   | Electrostatic Discharge                                     | EN 61000-4-2        | 8 kV air discharge                                     |
|                   | Burst Interference  | EN 61000-4-4        | 2 kV power cables, 2 kV control                        |
|                   | Radio Frequency Electromagnetic Field, amplitude modulated  | ENV 50 140          | 80-1000 MHz, 10 V/m, 80% AM, power and signal lines    |
|                   | Radio-frequency Electromagnetic Field, pulse modulated      | ENV 50 204          | 900 MHz, 10 V/m 50% duty cycle, 200 Hz repetition rate |

## Only Frame Size C

### Class 3: Filtered - for residential, commercial and light industry

This level of performance will allow the manufacturer / assembler to self-certify compliance of their apparatus with the EMC directive for the residential, commercial and light industrial environment as regards the EMC performance characteristics of the power drive system. Performance limits are as specified in the generic emission and immunity standards EN 50081-1 and EN 50082-1.

Table 9-3 Filtered for Residential, Commercial and Light Industry

| EMC Phenomenon    |   | Standard            | Level  |
|-------------------|---|---------------------|--|
| <b>Emissions:</b> | Radiated Emissions*   | EN 55011            | Limit B  |
|                   | Conducted Emissions   | EN 55011            | Limit B  |
| <b>Immunity:</b>  | Supply Voltage Distortion                                   | IEC 1000-2-4 (1993) |  |
|                   | Voltage Fluctuations, Dips, Unbalance, Frequency Variations | IEC 1000-2-1        |  |
|                   | Magnetic Fields   | EN 61000-4-8        | 50 Hz, 30 A/m  |
|                   | Electrostatic Discharge                                     | EN 61000-4-2        | 8 kV air discharge                                     |
|                   | Burst Interference  | EN 61000-4-4        | 2 kV power cables, 2 kV control                        |
|                   | Radio Frequency Electromagnetic Field, amplitude modulated  | ENV 50 140          | 80-1000 MHz, 10 V/m, 80% AM, power and signal lines    |
|                   | Radio-frequency Electromagnetic Field, pulse modulated      | ENV 50 204          | 900 MHz, 10 V/m 50% duty cycle, 200 Hz repetition rate |

\* These limits are dependent on the inverter being correctly installed inside a metallic switchgear enclosure. The limits will not be met if the inverter is not enclosed.

#### Notes

- To achieve these performance levels, you must not exceed the default Pulse frequency nor use cables longer than 25 m.
- The MICROMASTER inverters are intended **exclusively for professional applications**. Therefore, they do not fall within the scope of the harmonics emissions specification EN 61000-3-2.
- Maximum mains supply voltage when filters are fitted is 480 V.

Table 9-4 Compliance Table

**Frame Sizes C to F**

| Model  | Remarks  |
|--|--|
| <b>Class 1 – General Industrial</b>                                      |  |
| 6SE6430-2U***-**A0   | Unfiltered units, all voltages and powers.                       |
| <b>Class 2 – Filtered Industrial</b>                                     |  |
| 6SE6430-2A***-**A0   | All units with integral Class A filters                          |
| <b>Class 3 – Filtered for residential, commercial and light industry</b> |  |
| 6SE6430-2U***-**A0 with<br>6SE6400-2FB0*-***0                            | Unfiltered units fitted with external Class B footprint filters. |
| * denotes any value is allowed.  |  |

**Frame Sizes FX to GX**

| Model                                | Remarks  |
|--------------------------------------|--|
| <b>Class 1 – General Industrial</b>  |  |
| 6SE6430-2U***-**A0                   | Unfiltered units, all voltages and powers.   |
| <b>Class 2 – Filtered Industrial</b> |  |
| 6SE6440-2U***-**A0                   | With EMI filter (available as an option) the limiting values of the EN 55011, Class A are fulfilled for conducted emission.<br>(line commutating choke required) |

# Appendices

## A Changing the Operator Panel

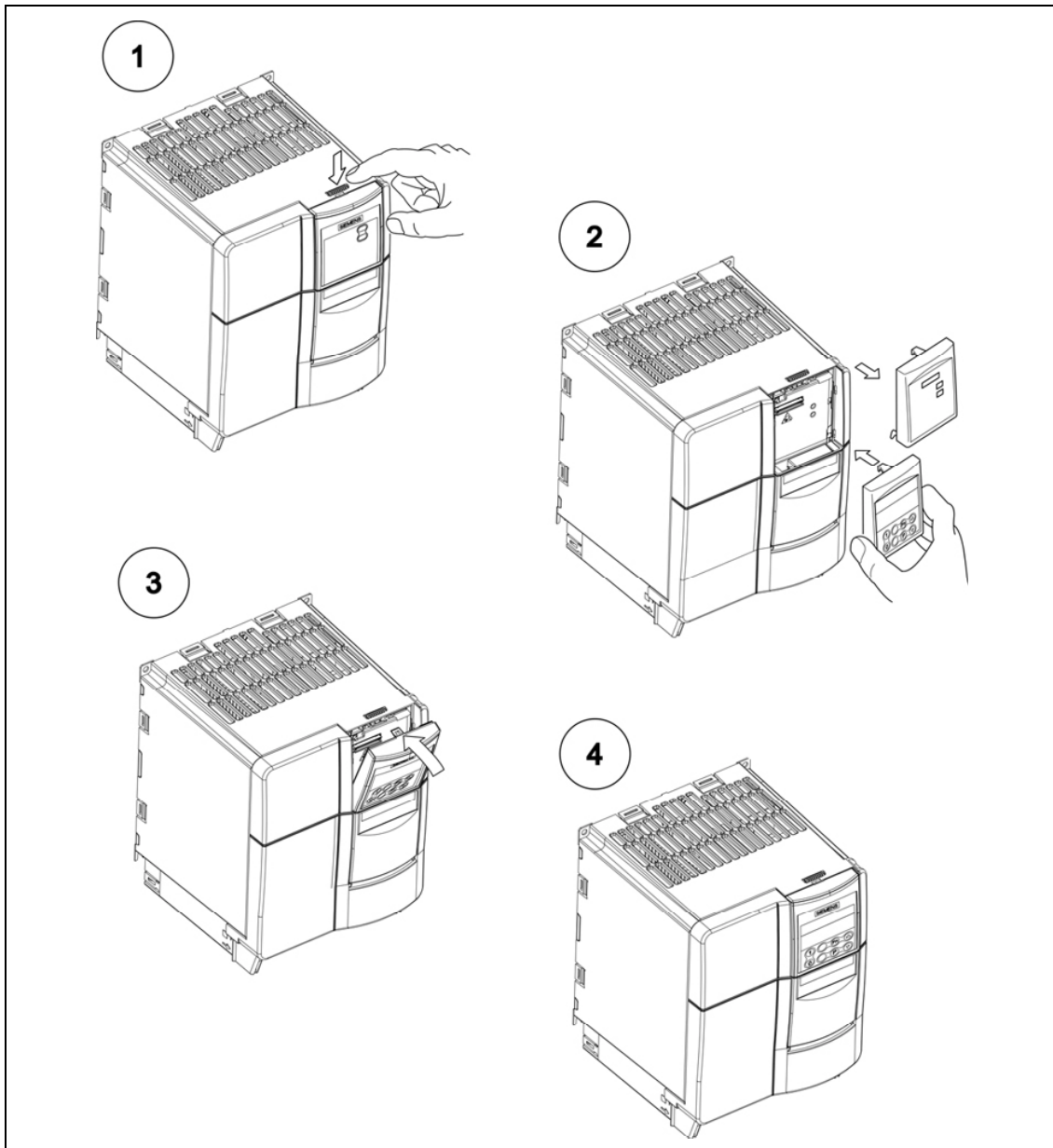

## B Removing Front Covers

### B.1 Removing Front Covers Frame Size C

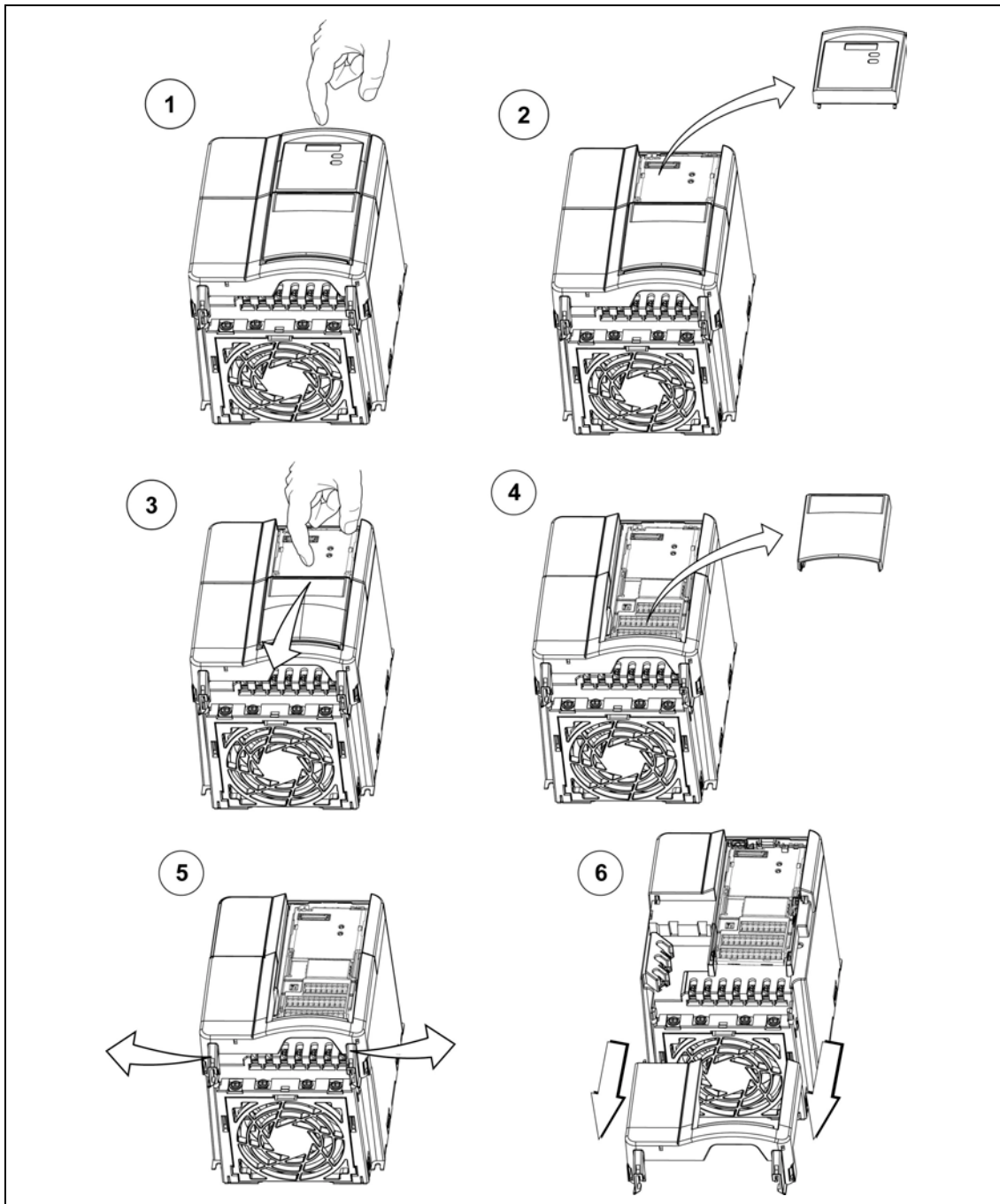



## B.2 Removing Front Covers Frame Sizes D and E

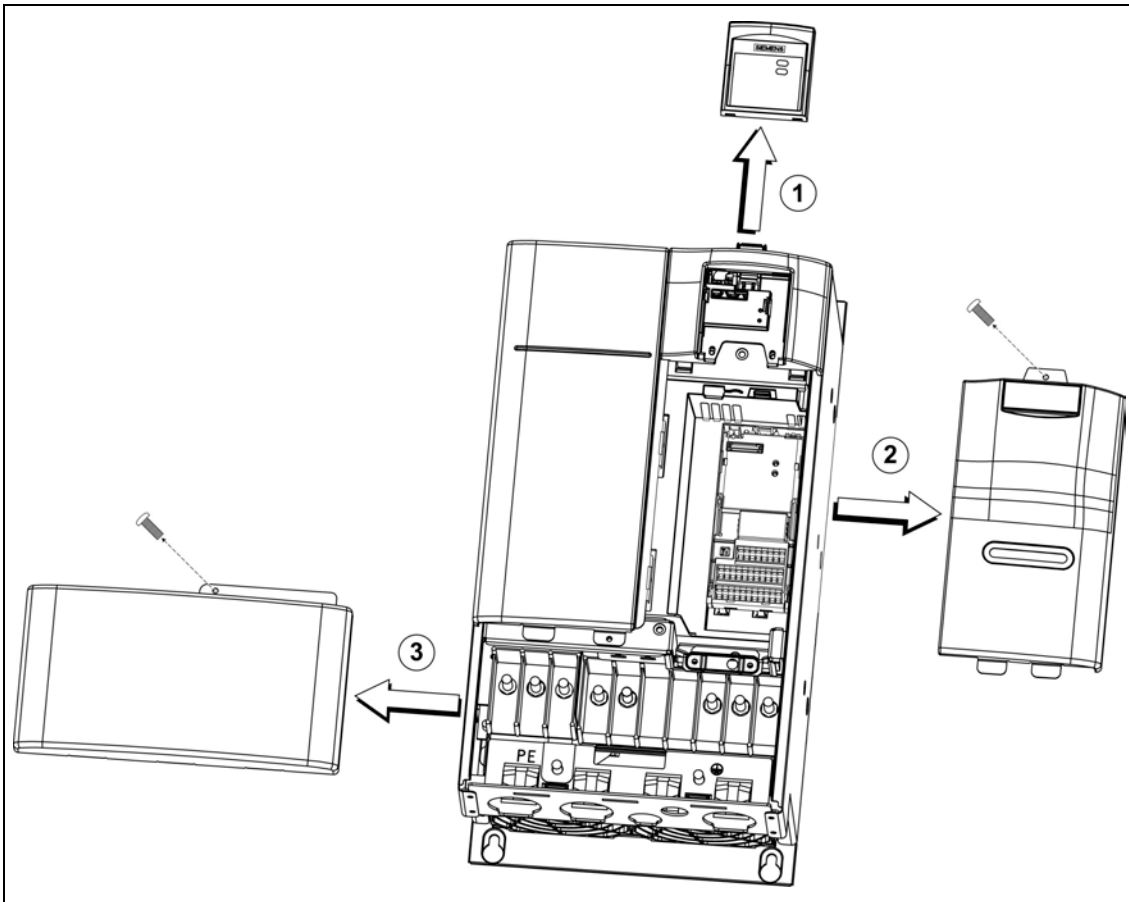

### B.3 Removing Covers Frame Size F

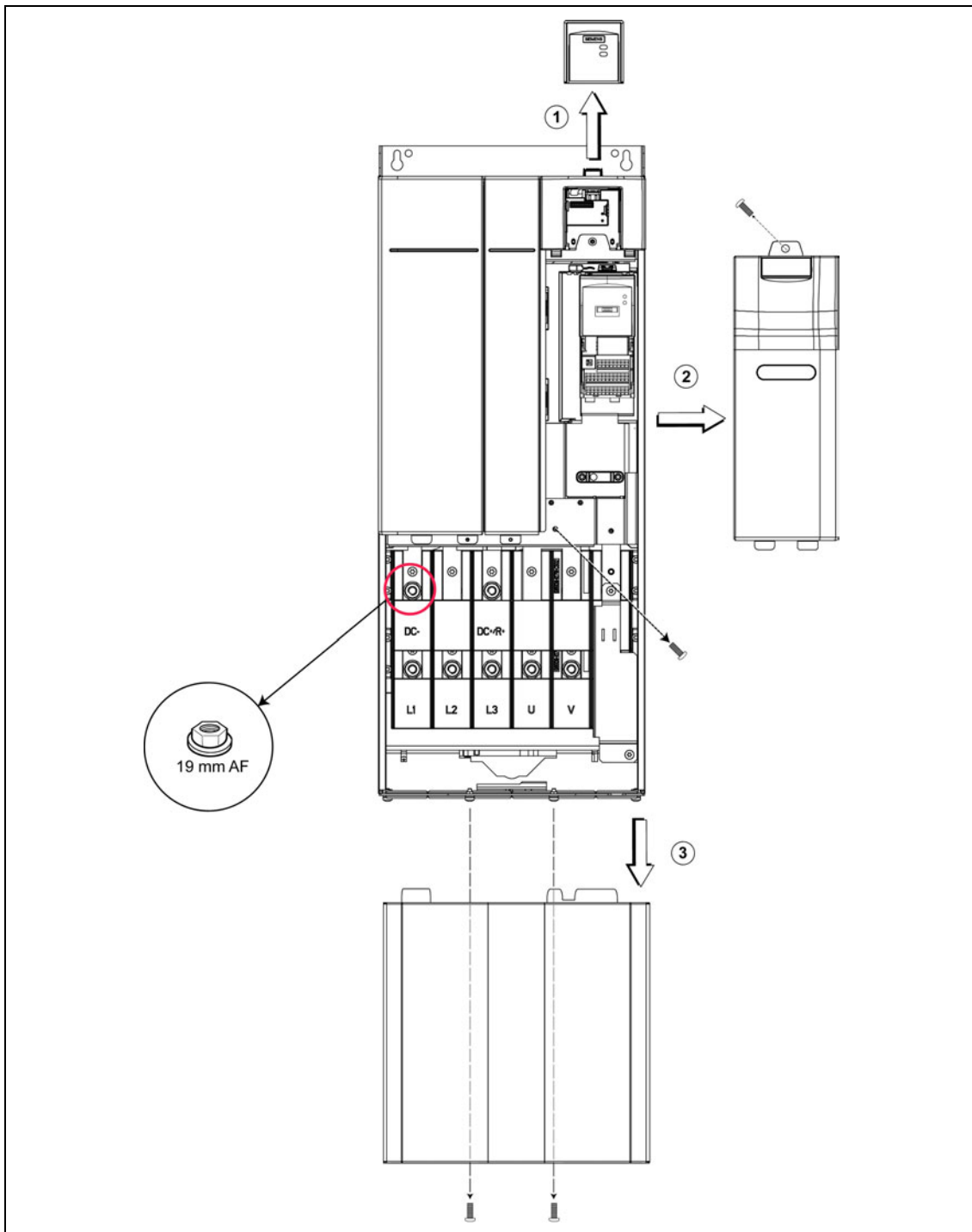

### B.4 Removing Front Covers Frame Sizes FX and GX

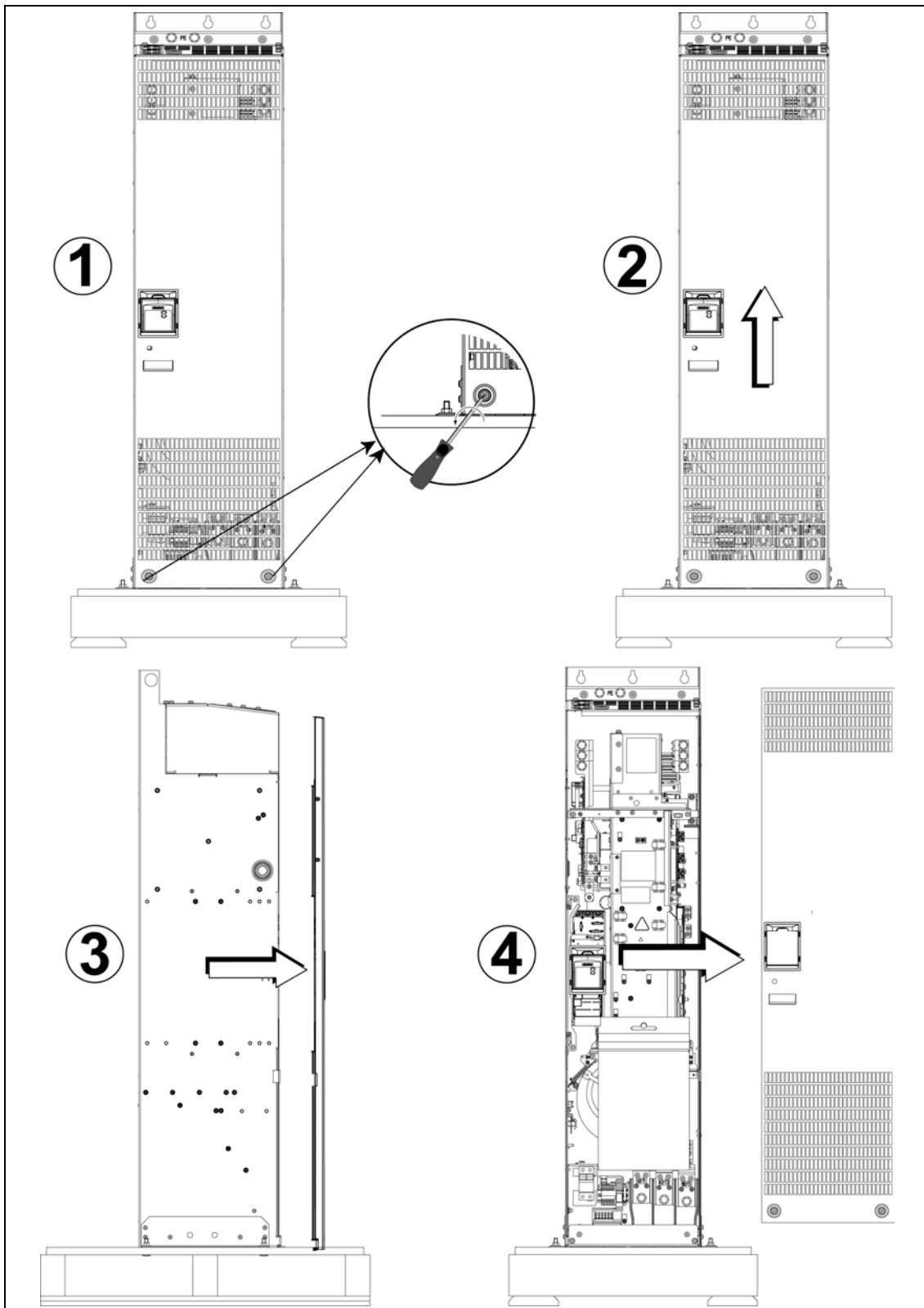

## C Removing the I/O Board

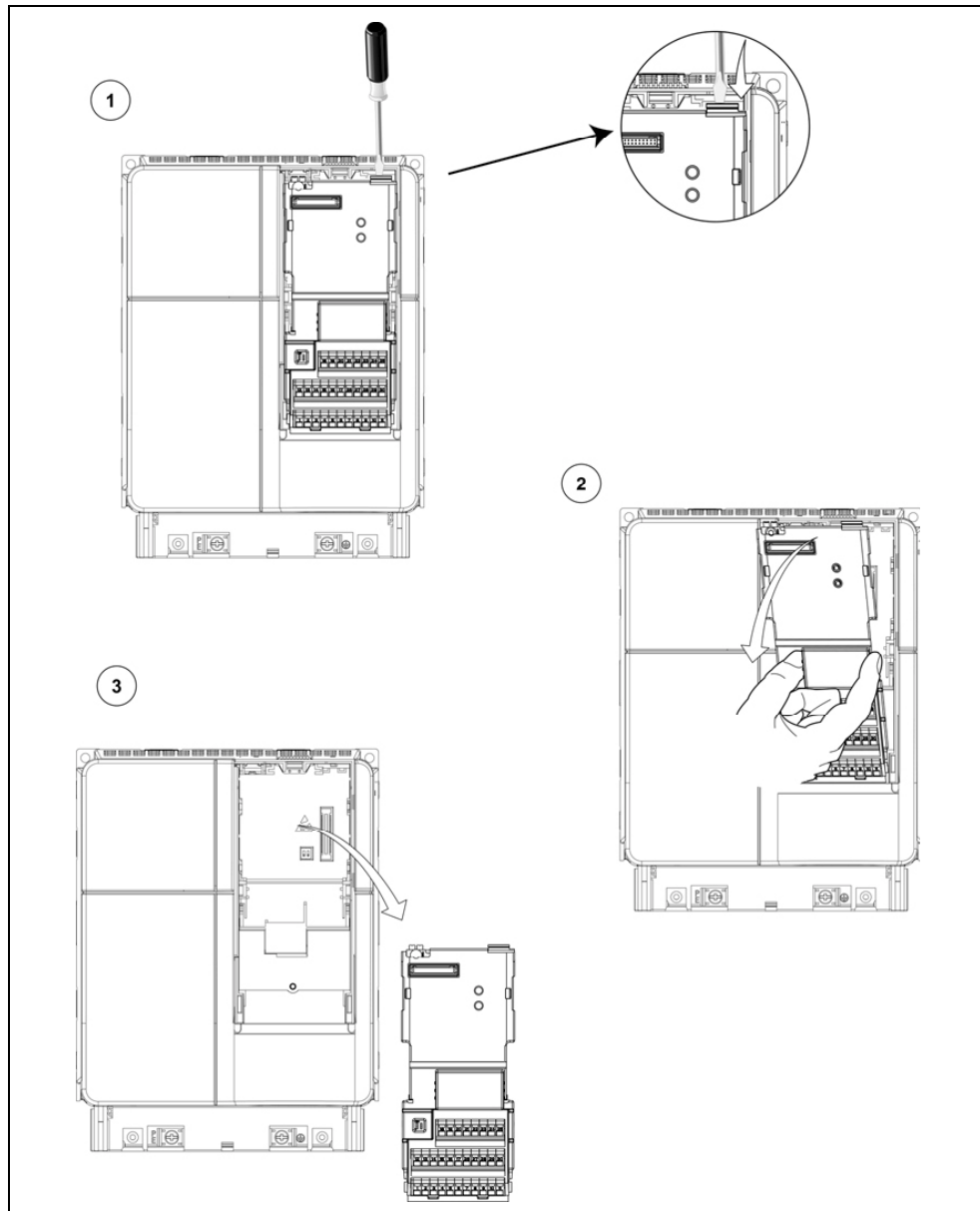

---

**NOTICE**

1. Only a small amount of pressure is required to release the I/O Board catch.
  2. the I/O Board is removed using the same technique regardless of frame size.
-

## D Removing 'Y' Cap

### D.1 Removing 'Y' Cap Frame Size C

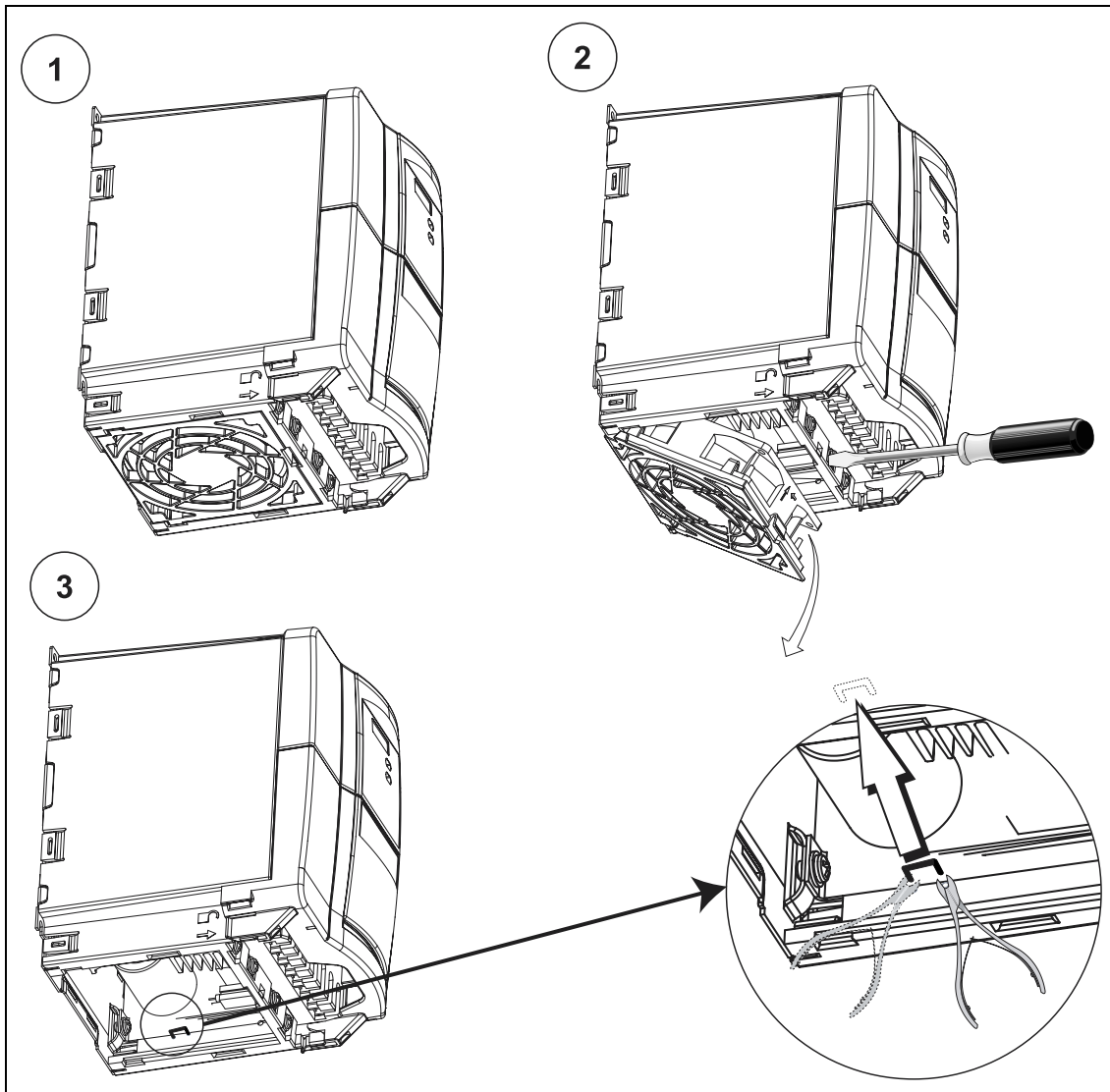

## D.2 Removing 'Y' Cap Frame Sizes D and E

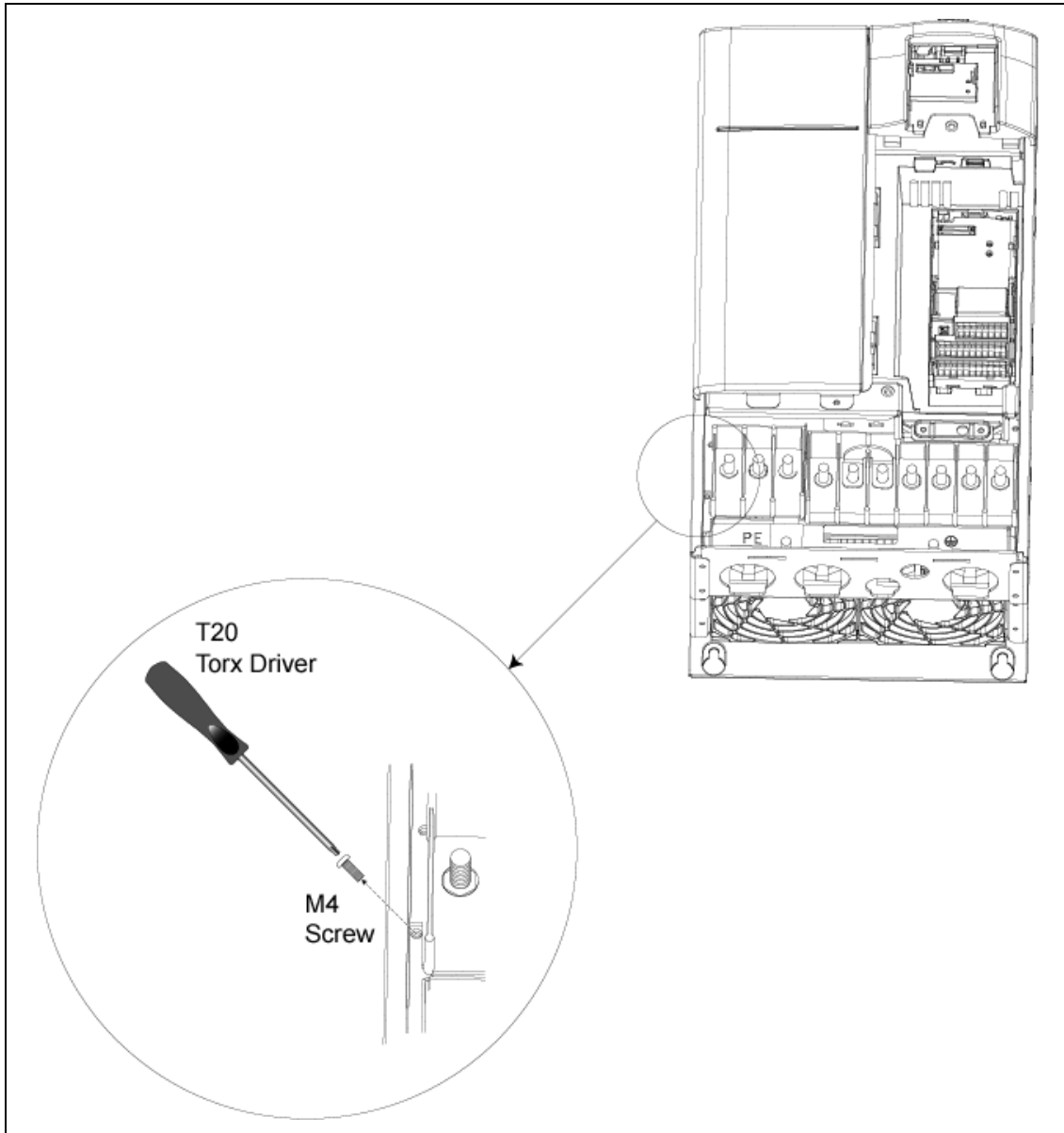

### D.3 Removing 'Y' Cap Frame Sizes F

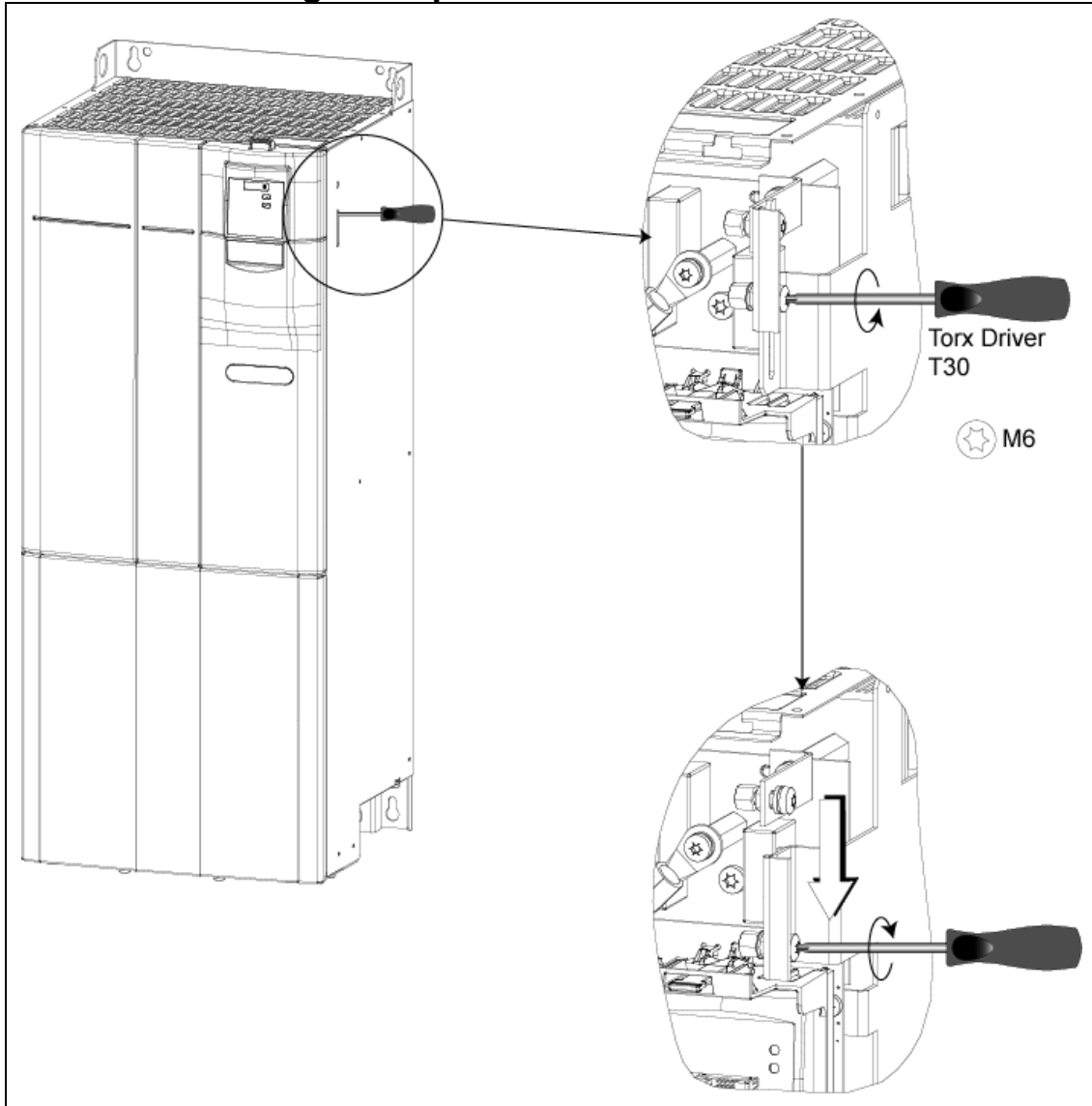

### D.4 Removing 'Y' Cap Frame Sizes FX

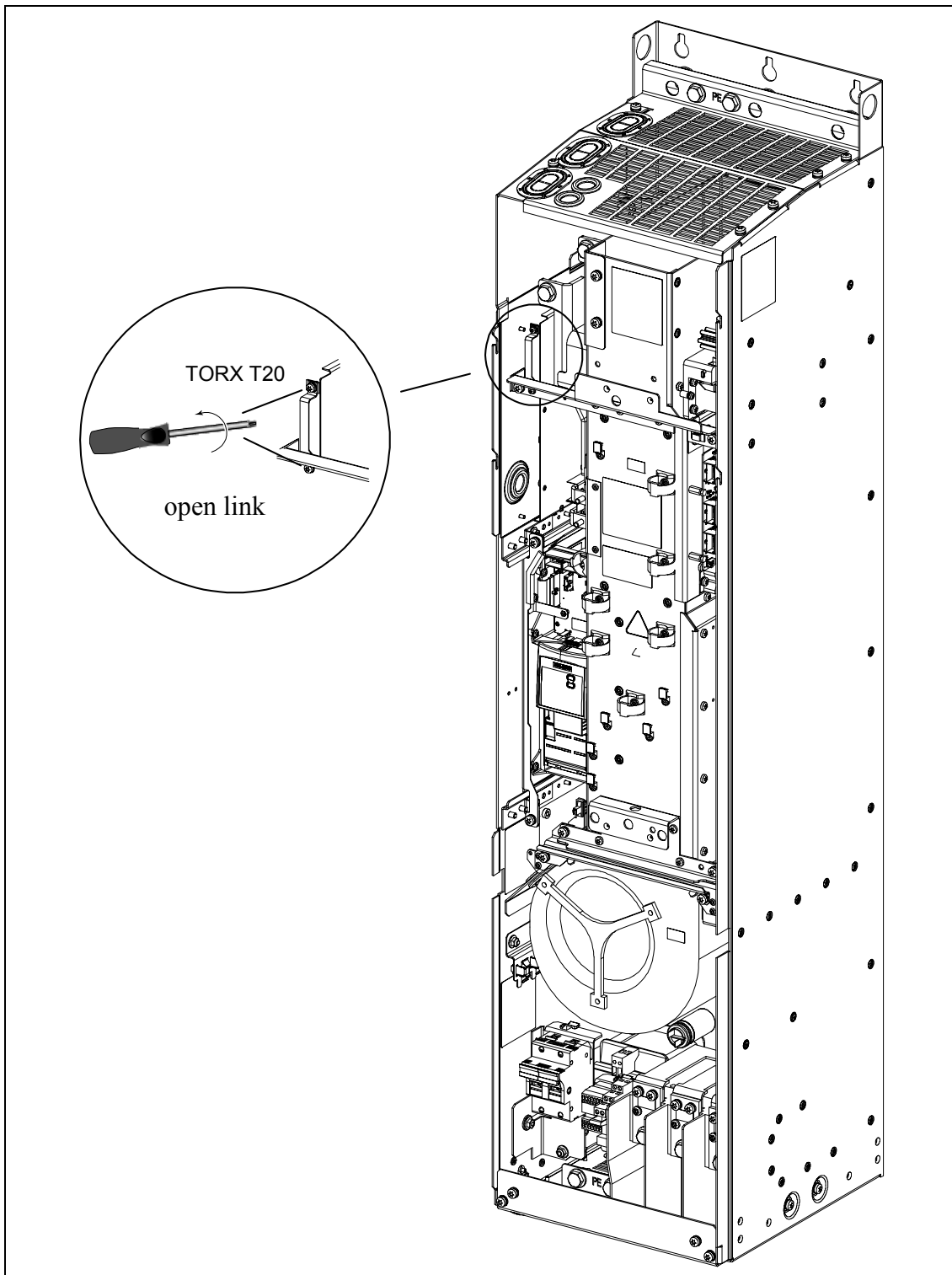



### D.5 Removing 'Y' Cap Frame Sizes GX

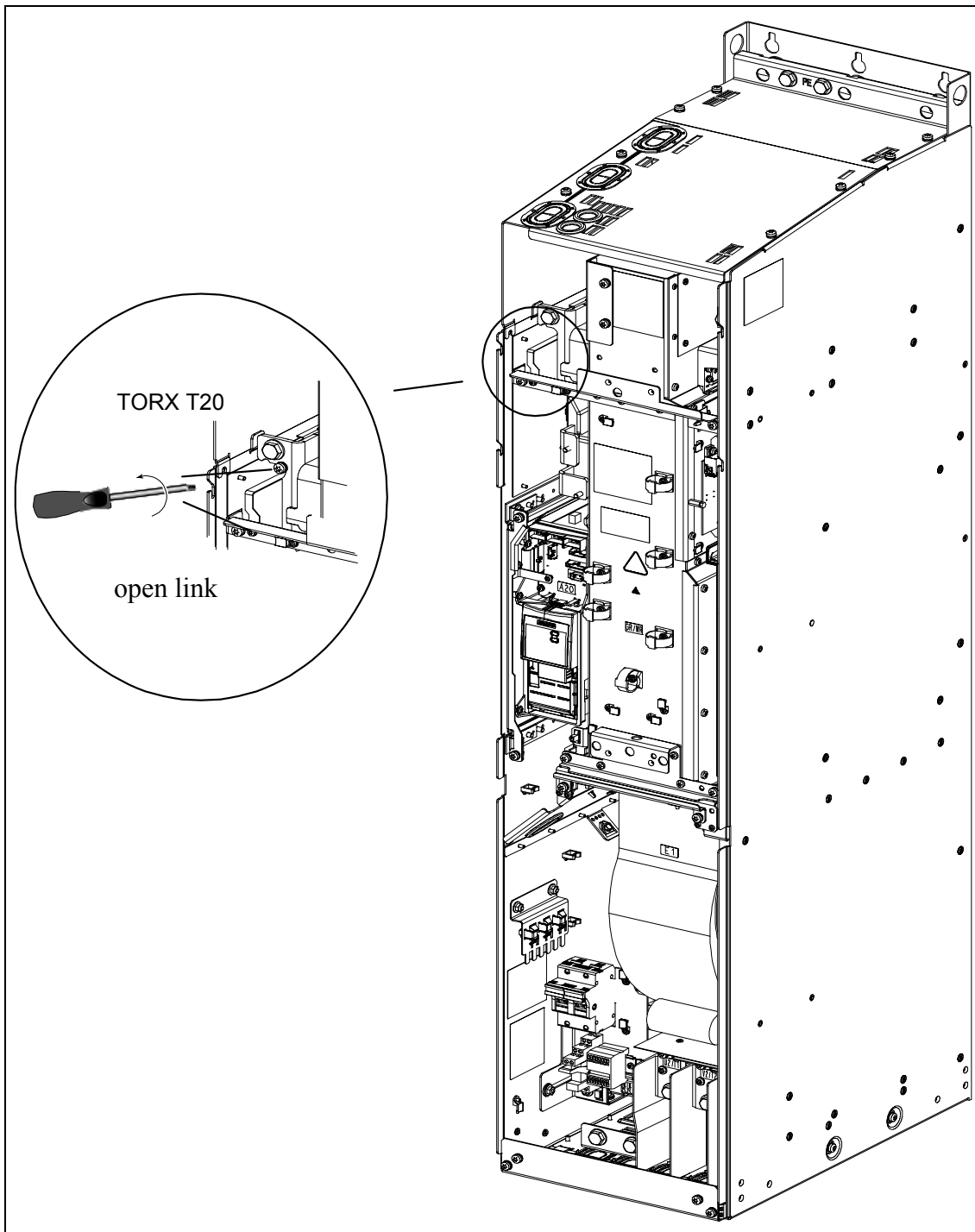

## E Applicable Standards



---

### European Low Voltage Directive

The MICROMASTER product range complies with the requirements of the Low Voltage Directive 73/23/EEC as amended by Directive 98/68/EEC. The units are certified for compliance with the following standards:

EN 60146-1-1 Semiconductor inverters – General requirements and line commutated inverters

EN 60204-1 Safety of machinery - Electrical equipment of machines

---

### European Machinery Directive

The MICROMASTER inverter series does not fall under the scope of the Machinery Directive. However, the products have been fully evaluated for compliance with the essential Health & Safety requirements of the directive when used in a typical machine application. A Declaration of Incorporation is available on request.

---

### European EMC Directive

When installed according to the recommendations described in this manual, the MICROMASTER fulfils all requirements of the EMC Directive as defined by the EMC Product Standard for Power Drive Systems EN 61800-3.

---



---

### Underwriters Laboratories

UL and CUL LISTED POWER CONVERSION EQUIPMENT 5B33 for use in a pollution degree 2.

---

### ISO 9001

Siemens plc operates a quality management system, which complies with the requirements of ISO 9001.

---

## F List of Abbreviations

|          |   |
|----------|---|
| AC       | Alternating current                             |
| AD       | Analog digital converter                        |
| ADC      | Analog digital converter                        |
| ADR      | Address   |
| AFM      | Additional frequency modification               |
| AIN      | Analog input                                    |
| AOP      | Advanced operator panel                         |
| AOUT     | Analog output                                   |
| ASP      | Analog setpoint                                 |
| ASVM     | Asymmetric space vector modulation              |
| BCC      | Block check character                           |
| BCD      | Binary-coded decimal code                       |
| BI       | Binector input                                  |
| BICO     | Binector / connector                            |
| BO       | Binector output                                 |
| BOP      | Basic operator panel                            |
| C        | Commissioning                                   |
| CB       | Communication board                             |
| CCW      | Counter-clockwise                               |
| CDS      | Command data set                                |
| CI       | Connector input                                 |
| CM       | Configuration management                        |
| CMD      | Commando  |
| CMM      | Combimaster                                     |
| CO       | Connector output                                |
| CO/BO    | Connector output / Binector output              |
| COM      | Common (terminal that is connected to NO or NC) |
| COM-Link | Communication link                              |
| CT       | Commissining, read to run                       |
| CT       | Constant torque                                 |
| CUT      | Commissining, run, read to run                  |
| CW       | Clockwise                                       |
| DA       | Digital analog converter                        |
| DAC      | Digital analog converter                        |
| DC       | Direct current                                  |
| DDS      | Drive data set                                  |
| DIN      | Digital input                                   |
| DIP      | DIP switch                                      |

|        |   |
|--------|---|
| DOUT   | Digital output                                      |
| DS     | Drive state   |
| EEC    | European Economic Community                         |
| EEPROM | Electrical erasable programmable read-only          |
| ELCB   | Earth leakage circuit breaker                       |
| EMC    | Electro-magnetic compatibility                      |
| EMF    | Electromotive force                                 |
| EMI    | Electro-magnetic interference                       |
| FAQ    | Frequently asked questions                          |
| FCC    | Flux current control                                |
| FCL    | Fast current limit                                  |
| FF     | Fixed frequency                                     |
| FFB    | Free function block                                 |
| FOC    | Field orientated control                            |
| FSA    | Frame size A  |
| GSG    | Getting started guide                               |
| GUI ID | Global unique identifier                            |
| HIW    | Main actual value                                   |
| HSW    | Main setpoint                                       |
| HTL    | High-threshold logic                                |
| I/O    | Input and output                                    |
| IBN    | Commissioning                                       |
| IGBT   | Insulated gate bipolar transistor                   |
| IND    | Sub-index   |
| JOG    | Jog   |
| KIB    | Kinetic buffering                                   |
| KTY    |   |
| LCD    | Liquid crystal display                              |
| LED    | Light emitting diode                                |
| LGE    | Length  |
| MHB    | Motor holding brake                                 |
| MM4    | MICROMASTER 4th. Generation                         |
| MOP    | Motor potentiometer                                 |
| NC     | Normally closed                                     |
| NO     | Normally open                                       |
| NPN    |   |
| OPI    | Operating instructions                              |
| PDS    | Power drive system                                  |
| PID    | PID controller (proportional, integral, derivative) |
| PKE    | Parameter ID  |
| PKW    | Parameter ID value                                  |
| PLC    | Programmable logic controller                       |
| PLI    | Parameter list                                      |
| PNP    |   |

---

|      |                                  |
|------|----------------------------------|
| PPO  | Parameter process data object    |
| PTC  | Positive temperature coefficient |
| PWE  | Parameter value                  |
| PWM  | Pulse-width modulation           |
| PX   | Power extension                  |
| PZD  | Process data                     |
| QC   | Quick commissioning              |
| RAM  | Random-access memory             |
| RCCB | Residual current circuit breaker |
| RCD  | Residual current device          |
| RFG  | Ramp function generator          |
| RFI  | Radio-frequency interference     |
| RPM  | Revolutions per minute           |
| SCL  | Scaling                          |
| SDP  | Status display panel             |
| SLVC | Sensorless vector control        |
| STW  | Control word                     |
| STX  | Start of text                    |
| SVM  | Space vector modulation          |
| TTL  | Transistor-transistor logic      |
| USS  | Universal serial interface       |
| VC   | Vector control                   |
| VT   | Variable torque                  |
| ZSW  | Status word                      |



# Index

## A

- Access Levels · 74
- Adaptation of fan voltage · 38
- Altitude · 22
- Ambient operating conditions
  - Altitude · 22
  - Atmospheric Pollution · 23
  - Electromagnetic Radiation · 23
  - Humidity Range · 22
  - Installation und Kühlung · 23
  - Shock · 22
  - Temperature · 22
  - Vibration · 22
  - Water hazard · 23
- Ambient operating conditions · 22
- Applicable standards
  - European EMC Directive · 136
  - European Low Voltage Directive · 136
  - European Machinery Directive · 136
  - ISO 9001 · 136
  - Underwriters Laboratories · 136
- Atmospheric pollution · 23

## B

- Basic operation
  - changing parameters with BOP-2 · 53
  - external motor thermal overload protection · 58, 61
  - general · 60
  - with BOP-2 · 60
  - with SDP · 49
- Belt Failure Detection · 69
- BOP-2
  - default settings with BOP-2 · 51
  - operation with BOP-2 · 51
- Bypass Mode · 68

## C

- Commissioning · 43
- Compound braking · 66
- connection drawing – frame size FX · 34
- connection drawing – frame size GX · 36
- Connection Terminals · 33
- Contact address · 5

- Control modes · 67
- Current reduction depending on pulse frequency · 109

## D

- DC braking · 66
- Default settings · 51
- Dimensions and Torques · 28
- Drill pattern for MICROMASTER 440 · 25

## E

- Electrical Installation · 30
- Electro-Magnetic Compatibility
  - EC type-examination certificate · 118
  - general · 117, 118
  - self-certification · 118
  - technical construction file · 118
- Electro-Magnetic Interference · 39
  - avoiding EMI · 39
- Electromagnetic radiation · 23
- EMC · 118
- EMC Directive Compliance · 118
- EMC performance
  - filtered for residential, commercial and light industry · 121
  - filtered industrial class · 120
  - general industrial class · 119
- EMI · 39
- Energy Saving Mode · 71

## F

- Fan fuses · 38
- Fault messages
  - with the BOP-2 fitted · 95
  - with the SDP fitted · 94
- Faults and Alarms
  - with BOP-2 · 72
  - with SDP · 72
- Features · 17
- flux current control (FCC) · 67
- Foreword · 5
- Free Function Blocks · 72
- Frequency set point · 64

**H**

Humidity Range · 22

**I**

Installation · 19

after a period of storage · 19, 21

Installation dimensions for MICROMASTER  
440 Version FX · 26

Installation of options in the electronic box ·  
29

Installation und Kühlung · 23

Internet Home Address · 5

Inverter block diagram · 45

**L**

Linear U/f control · 67

Long cables

operation with · 31

**M**

Main characteristics · 17

Mechanical Installation · 24

MICROMASTER 430

general · 16

main characteristics · 17

performance characteristics · 18

protection characteristics · 18

specifications · 107

Motor connections · 32

Motor data · 58

Motor Staging · 70

Multiple point U/f control · 67

**O**

Operation

OFF and brake function · 65

Operation with

long cables · 31

Residual Current Device · 31

ungrounded IT supplies · 31

Operator panels

BOP-2 · 51

changing the operator panel · 123

SDP · 48

Options

Device-dependent options · 115

Device-independent options · 115

Options for electronic box · 29

Overview · 15

**P**

Parabolic U/f control · 67

Parameter

Systemparameter · 73

Parameters

changing parameters with BOP-2 · 53

Performance characteristics · 18

Performance Ratings · 108

Power and motor connections · 32

single phase · 37

Protection characteristics · 18

**Q**

Qualified personnel · 6

Quick commissioning · 55

**R**

Removing 'Y' Cap Frame Sizes C · 131

Removing 'Y' Cap Frame Sizes D and E ·  
132

Removing 'Y' Cap Frame Sizes F · 133

Removing Covers Frame Size C · 124

Removing Covers Frame Size F · 127

Removing Covers Frame Sizes D and E ·  
125, 128

Removing the I/O Board · 130

Reset to Factory default · 58

Residual Current Device

operation with · 31

**S**

Safety instructions · 7

Screening Methods · 40

SDP

Default settings · 48

operation with SDP · 48

Shock · 22

Specifications · 110

**T**

Technical Support · 5

Troubleshooting · 93

**U**

Ungrounded (IT) supplies

operation with · 31

**W**

Warnings, cautions & notes



commissioning · 8  
definitions · 6  
dismantling & disposal · 9  
general · 7  
operation · 9  
repair · 9

transport & storage · 8  
Water hazard · 23  
Wire Sizes & Terminal Torques · 109  
Wiring Guidelines EMI · 40



**Suggestions and/or Corrections**

|  |   |
|--|---|
| <p>To:<br/>Siemens AG<br/>Automation &amp; Drives Group<br/>SD VM 4<br/>P.O. Box 3269<br/><br/>D-91050 Erlangen<br/>Federal Republic of Germany<br/><br/>Email:<br/><a href="mailto:Technical.documentation@con.siemens.co.uk">Technical.documentation@con.siemens.co.uk</a></p> | <p><b>Suggestions</b></p> <p><b>Corrections</b></p> <p>For Publication/Manual:<br/>MICROMASTER 430</p> <p>User Documentation</p>  |
| <p><b>From</b></p> <p>Name: _____</p> <p>Company/Service Department _____</p> <p>Address: _____</p> <p>_____</p> <p>Telephone: _____ / _____</p> <p>Telefax: _____ / _____</p>   | <p>Operating Instructions</p> <p>Order Number:<br/>6SE6400-5AE00-0BP0</p> <p>Date of Issue: 12/02</p> <p>Should you come across any printing errors when reading this publication, please notify us on this sheet.</p> <p>Suggestions for improvement are also welcome.</p> |





Siemens AG  
Bereich Automation and Drives (A&D)  
Geschäftsgebiet Standard Drives (SD)  
Postfach 3269, D-91050 Erlangen  
Federal Republic of Germany

© Siemens AG, 2002  
Subject to change without prior notice

---

Siemens Aktiengesellschaft

Order No.: 6SE6400-5AE00-0BP0  
Date: 12/02

