

For close integration of IS circuits into process-connected systems

MTL4000 SERIES

isolating IS interface units



- ◆ Compact modular design with 'plug-in' connections
- ◆ High module/channel packing densities
- ◆ System backplanes with bussed power and safe-area connections
- ◆ Custom-designed backplanes for closest integration into process-connected systems
- ◆ Reduced system engineering and installation costs
- ◆ Range of standard enclosures protected to IP65
- ◆ Modules certified internationally for equipment and wiring in all zones and explosive atmospheres
- ◆ Patented hazardous-area connection UK2256326EU EP0516455B1

The MTL4000 Series of 'third-generation' isolating interface units introduces new concepts for integrating intrinsic safety into large or medium sized process-connected systems. Being exceptionally compact, the units give high packing densities. Units plug into system backplanes with safe-area connections made by multiway connectors – an approach which not only simplifies engineering but also reduces installation and maintenance costs.

Modules handle the majority of applications covering on/off or analogue signals between hazardous-area equipment and safe-area systems. Modules incorporate proven intrinsically safe isolation techniques internationally certified for protecting equipment and wiring in all zones and explosive atmospheres.

Key module design features include a multiway connector on the base of each unit which mates with a connector on the backplane to provide both safe-area and power supply connections. Hazardous-area connections are made by a single connector which plugs into the top of the module. These connectors are available with either screw-clamp terminals or crimp connectors. This use of removable connectors greatly simplifies installation and maintenance, so reducing time, cost, and the risk of errors. Status LEDs, configuration switches and ports are located on the tops of individual modules for easy access.

The compact design (modules are only 16mm wide) reduces weight and gives exceptionally high packing densities.

Based on proven IS isolation technology, MTL4000 Series modules do not need a high integrity earth and the associated circuits can be left floating or be earthed at any one point in accordance with good earthing practices. MTL4000 Series provides single channel single loop integrity across the range with the addition of dual channel options mainly for the switch/proximity modules.

Line fault detection (LFD) facilities are provided on the MTL4014/4015/4016/4017/4113X switch/proximity detectors, the MTL4023 solenoid/alarm driver and the MTL4045B/4046 4/20mA isolating drivers. Analogue input units such as the MTL4041B provide line fault detection by repeating o/c or s/c currents to the safe-area control system.

System backplanes are located in safe areas and, since the hazardous-area circuits are connected directly to the modules, do not need to be certified. See MTL series backplanes, enclosures and accessories for full details.



MTL4013 SWITCH/ PROXIMITY DETECTOR INTERFACE

two-channel, solid-state output



The MTL4013 is a two-channel unit enabling safe-area loads to be controlled, through logic compatible solid-state outputs, by switches or proximity detectors located in hazardous areas. It can also be used with positive displacement (PD) flowmeters and some turbine meters. Earth fault detection is available optionally by using the MTL4013 with an MTL4220 earth leakage detector. Power and switch status is indicated by LEDs located on top of the module.

SPECIFICATION

See also common specification, cable parameters and approvals

Number of channels

Two

Location of switches

Zone 0, IIC, T6 hazardous area
Div.1, Group A, hazardous location

Location of proximity detector

Zone 0, IIC, T4-6 if suitably certified
Div.1, Group A, hazardous location

Voltage applied to sensor

7.0V – 9.0V dc from 1k Ω

Input/output characteristics

Output on if $>2.1\text{mA}^*$ ($<2\text{k}\Omega$) in sensor circuit
Output off if $<1.2\text{mA}^*$ ($>10\text{k}\Omega$) in sensor circuit

Hysteresis: 200 μA (650 Ω) nominal

*NAMUR and DIN 19234 standards for proximity detectors

'No-fail' earth fault protection

Enabled by connecting terminals 3 and 6 to an MTL4220 earth leakage detector

Fault on either line proclaimed: unit continues working

Note: if it is required to maintain isolation between the two channels, separate earth leakage detectors are needed

Output characteristics

Operating frequency: dc to 5kHz

Maximum off-state voltage: 35V

Maximum off-state leakage current: 10 μA

Maximum on-state voltage drop: $[1 + (0.1 \times \text{current in mA})]$ V

Maximum on-state current: 50mA

Note: each output is Zener-diode protected against inductive loads

LED indicators

Amber: one provided for each channel, ON when output circuit is closed

Green: one provided for power indication

Power requirement, Vs

47.5mA at 24V dc

45mA at 20V dc

50mA at 35V dc

Power dissipation within unit

1.15W at 24V

1.75W at 35V

Isolation

250V ac between safe and hazardous area circuits

Safety description for each channel

10.5V, 800 Ω , 14mA

FM entity parameters

$V_{OC} = 10.5\text{V}$ dc, $I_{SC} = 14\text{mA}$, $C_a = 2.4\mu\text{F}$, $L_a = 165\text{mH}$

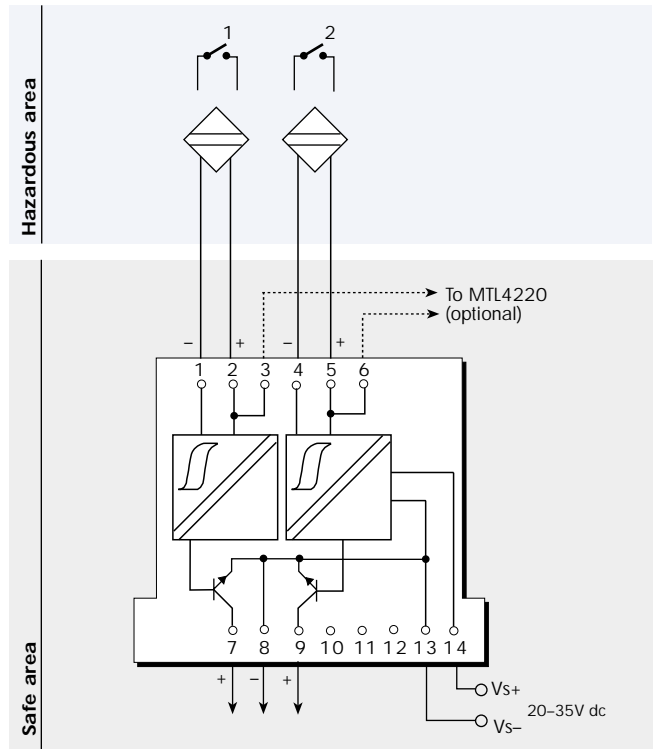

Terminal	Function
1	Input 1 -ve
2	Input 1 +ve
3	Optional link from input 1 to MTL4220
4	Input 2 -ve
5	Input 2 +ve
6	Optional link from input 2 to MTL4220
7	Output 1 +ve
8	Outputs 1/2 -ve
9	Output 2 +ve
13	Supply -ve
14	Supply +ve



EUROPE (EMEA)
AMERICAS
ASIA PACIFIC
E-mail: enquiry@mtl-inst.com

Tel: +44 (0)1582 723633
Tel: +1 603 926 0090
Tel: +65 487 7887

Fax: +44 (0)1582 422283
Fax: +1 603 926 1899
Fax: +65 487 7997

Web site: www.mtl-inst.com

MTL4014 SWITCH/ PROXIMITY DETECTOR INTERFACE

with line fault detection



The MTL4014 enables a safe-area load to be controlled by a proximity detector or switch located in a hazardous area through a reed relay. Line faults are signalled through a separate reed relay. The line fault detection (LFD) function can be used with both proximity detectors and switches, provided that for switches suitable resistors are added as shown in the circuit diagram. 'No-fail' earth fault detection on either line can be provided by connecting an MTL4220 earth leakage detector to terminal 6.

SPECIFICATION

See also common specification, cable parameters and approvals

Number of channels

One

Location of switch

Zone 0, IIC, T6 hazardous area
Div.1, Group A, hazardous location

Location of proximity detector

Zone 0, IIC, T4-6 if suitably certified
Div.1, Group A, hazardous location

Voltage applied to sensor

7.0V – 9.0V dc from 1k Ω nominal

Input/output characteristics

Output closed if input >2.1mA* (<2k Ω)

Output open if input <1.2mA* (>10k Ω)

Hysteresis: 200 μ A (650 Ω) nominal

*NAMUR and DIN 19234 standards for proximity detectors

Line fault detection (LFD)

Line fault relay and channel relay open if input
<50 μ A (broken line)

or <100 Ω (shorted line)

Note: switch-type sensors must be fitted with resistors as shown in the diagram. LFD cannot be disabled.

'No-fail' earth fault protection

Enabled by connecting terminal 6 to an MTL4220 earth leakage detector

Fault on either line proclaimed: unit continues working

Relay output characteristics

Single-pole on/off, open when relay de-energised

Response time: 2ms maximum

Contact rating: 10W, 0.5A, 35V (dc)

Contact life expectancy: 10⁷ operations at maximum load

Note: reactive loads must be adequately suppressed

LED indicators

Amber: one provided for input, ON when output circuit is closed

Red: one provided for LFD, ON when line fault is detected

Green: one provided for power indication

Power requirement, Vs

45mA at 24V dc

50mA at 20V dc

36mA at 35V dc

Power dissipation within unit

1.1W at 24V

1.3W at 35V

Isolation

250V ac between safe and hazardous area circuits

Safety description

10.5V, 800 Ω , 14mA

FM entity parameters

V_{OC} = 10.5V dc, I_{SC} = 14mA, C_a = 2.4 μ F, L_a = 165mH

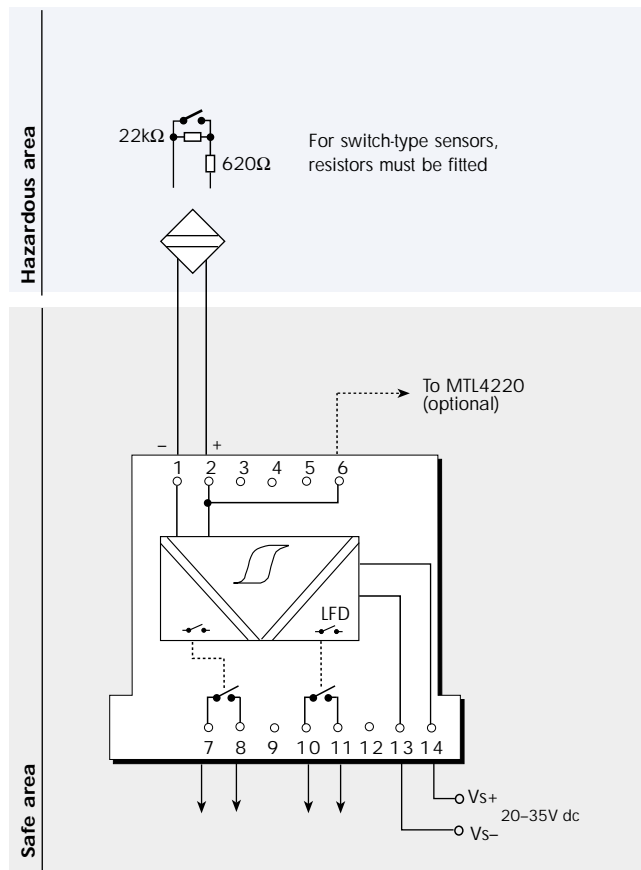

Terminal	Function
1	Input -ve
2	Input +ve
6	Optional link to MTL4220
7,8	Output
10,11	Line fault signal
13	Supply -ve
14	Supply +ve



MTL4015 SWITCH/ PROXIMITY DETECTOR INTERFACE UNIT

dual relay output



With the MTL4015, a switch or proximity detector located in a hazardous area can control two safe-area loads. The two safe-area outputs are made through relays. It is designed for applications where the status of a sensor needs to be fed to two separate systems (eg, control and shutdown). A phase-reversal switch, located on top of the module, allows an alarm signal to be signalled for either state of the sensors. Line fault detection (LFD) for broken or shorted lines is provided as also are facilities for earth fault detection. Power and switch status is indicated by LEDs located on top of the module.

SPECIFICATION

See also common specification, cable parameters and approvals

Number of channels

One

Location of switches

Zone 0, IIC, T6 hazardous area
Div.1, Group A, hazardous location

Location of proximity detector

Zone 0, IIC, T4-6 if suitably certified
Div.1, Group A, hazardous location

Voltage applied to sensor

7.0-9.0V dc from 1k Ω

Input/output characteristics

Outputs closed if $>2.1\text{mA}^*$ ($<2\text{k}\Omega$) in sensor circuit

Outputs open if $<1.2\text{mA}^*$ ($>10\text{k}\Omega$) in sensor circuit

Hysteresis: 200 μA (650 Ω) nominal

*NAMUR and DIN 19234 standards for proximity detectors

Phase reversal

The operation of the output can be reversed by a switch on top of the unit

Line fault detection (LFD)

By built-in line-fault detection (LFD)

Output opens if input current $<100\mu\text{A}$ (broken line) or $>6.5\text{mA}$ (shorted lines)

Note: to prevent false triggering of LFD, switch-type sensors must be fitted with resistors as shown in the diagram or LFD disabled by the switch on top of the unit

'No-fail' earth fault protection

Enabled by connecting terminal 6 to an MTL4220 earth leakage detector

Fault on either line of each channel proclaimed: unit continues working

Relay output characteristics

Double-pole on/off, open when relay de-energised

Response time: 2ms maximum

Contact rating: 10W, 0.5A, 35V (dc)

Contact life expectancy: 10^6 operations at maximum load

Note: reactive loads must be adequately suppressed

LED indicators

Amber: one provided, ON when output circuit is closed

Green: one provided for power indication

Power requirement, Vs

50mA at 24V dc

60mA at 20V dc

45mA at 35V dc

Power dissipation within unit

1.2W at 24V

1.6W at 35V

Isolation

250V ac between safe and hazardous area circuits

Safety description for each channel

10.5V, 800 Ω , 14mA

FM entity parameters

$V_{OC} = 10.5\text{V}$ dc, $I_{SC} = 14\text{mA}$, $C_a = 2.4\mu\text{F}$, $L_a = 165\text{mH}$

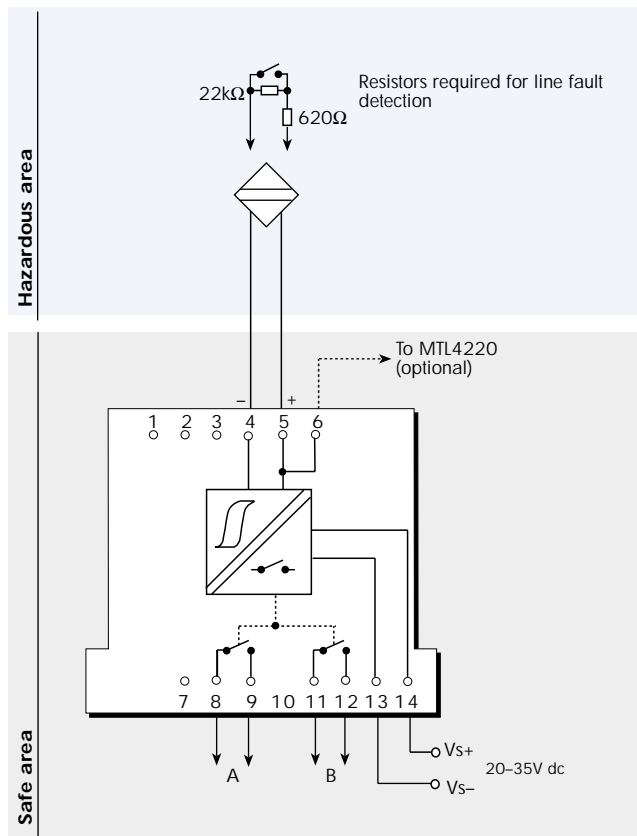

Terminal	Function
4	Input -ve
5	Input +ve
6	Optional link from input to MTL4220
8,9	Output A
11,12	Output B
13	Supply -ve
14	Supply +ve



MTL4016 SWITCH/ PROXIMITY DETECTOR INTERFACE UNIT

two-channel, dual relay output



With the MTL4016, two switches or proximity detectors located in a hazardous area can each control two safe-area loads. The four safe-area outputs are made through reed relays. It is designed for applications where the status of a sensor needs to be fed to two separate systems (eg, control and shutdown). Independent phase-reversal switches for each channel, located on top of the module, allow alarm signals to be signalled for either state of the sensors. Line fault detection (LFD) for broken or shorted lines is provided as also are facilities for earth fault detection. Power and switch status is indicated by LEDs located on top of the module.

SPECIFICATION

See also common specification, cable parameters and approvals

Number of channels

Two

Location of switches

Zone 0, IIC, T6 hazardous area
Div.1, Group A, hazardous location

Location of proximity detector

Zone 0, IIC, T4-6 if suitably certified
Div.1, Group A, hazardous location

Voltage applied to sensor

7.0V – 9.0V dc from 1k Ω

Input/output characteristics

Outputs closed if $>2.1\text{mA}^*$ ($<2\text{k}\Omega$) in sensor circuit
Outputs open if $<1.2\text{mA}^*$ ($>10\text{k}\Omega$) in sensor circuit
Hysteresis: 200 μA (650 Ω) nominal

*NAMUR and DIN 19234 standards for proximity detectors

Phase reversal

The operation of each channel can be reversed by independent switches on top of the unit

Line fault detection (LFD)

By built-in line-fault detection (LFD)
Outputs open if input current $<100\mu\text{A}$ (broken line) or $>6.5\text{mA}$ (shorted lines)

Note: to prevent false triggering of LFD, switch-type sensors must be fitted with resistors as shown in the diagram or LFD disabled by switches on top of the unit

'No-fail' earth fault protection

Enabled by connecting terminals 3 and 6 to an MTL4220 earth leakage detector

Fault on either line of each channel proclaimed: unit continues working

Note: to maintain isolation between the two channels, separate earth leakage detectors are needed

Relay output characteristics

Double-pole on/off, open when relay de-energised

Response time: 2ms maximum

Contact rating: 10W, 0.5A, 35V (dc)

Contact life expectancy: 10^6 operations at maximum load

Note: reactive loads must be adequately suppressed

LED indicators

Amber: one provided for each channel, ON when output circuit is closed

Green: one provided for power indication

Power requirement, V_s

50mA at 24V dc

60mA at 20V dc

45mA at 35V dc

Power dissipation within unit

1.2W at 24V

1.6W at 35V

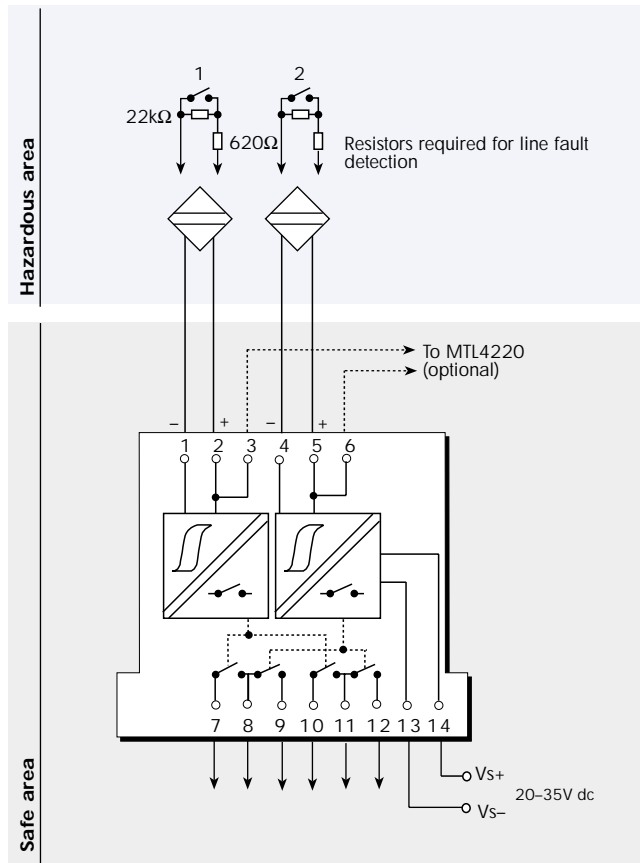

Terminal	Function
1	Input 1 -ve
2	Input 1 +ve
3	Optional link from input 1 to MTL4220
4	Input 2 -ve
5	Input 2 +ve
6	Optional link from input 2 to MTL4220
7,8	Output 1A
8,9	Output 2A
10,11	Output 1B
11,12	Output 2B
13	Supply -ve
14	Supply +ve

Isolation

250V ac between safe and hazardous area circuits

Safety description for each channel

10.5V, 800 Ω , 14mA

FM entity parameters

$V_{OC} = 10.5\text{V}$ dc, $I_{SC} = 14\text{mA}$, $C_a = 2.4\mu\text{F}$, $L_a = 165\text{mH}$



MTL4017 SWITCH/ PROXIMITY DETECTOR INTERFACE

two-channel with line fault detection 

With the MTL4017, two switches or proximity detectors located in a hazardous area can each control a safe-area load through a relay. Line faults are signalled through a separate relay. Line fault detection (LFD) can be used with proximity detectors or switches provided in the latter case suitable resistors are added as shown in the circuit diagram. 'No-fail' earth fault detection on either line of each channel can be provided by connecting an MTL4220 earth leakage detector to terminal 6.

SPECIFICATION

See also common specification, cable parameters and approvals

Number of channels

Two

Location of switch

Zone 0, IIC, T6 hazardous area
Div.1, Group A, hazardous location

Location of proximity detector

Zone 0, IIC, T4-6 if suitably certified
Div.1, Group A, hazardous location

Voltage applied to sensor

7.0V – 9.0V dc from 1k Ω nominal

Input/output characteristics

Output closed if input >2.1mA* (<2k Ω)
Output open if input <1.2mA* (>10k Ω)

Hysteresis: 200 μ A (650 Ω) nominal

*NAMUR and DIN 19234 standards for proximity detectors

Line fault detection (LFD)

Line fault relay and channel relay open if input
<50 μ A (broken line)

or <100 Ω (shorted lines)

Note: switch-type sensors must be fitted with resistors as shown in the diagram. LFD cannot be disabled.

'No-fail' earth fault protection

Enabled by connecting terminal 6 to an MTL4220 earth leakage detector

Fault on either line of each channel proclaimed: unit continues working

Relay output characteristics

Single-pole on/off, open when relay de-energised

Response time: 2ms maximum

Contact rating: 10W, 0.5A, 35V (dc)

Contact life expectancy: 10⁷ operations at maximum load

Note: reactive loads must be adequately suppressed

LED indicators

Amber: one provided for each channel, ON when output circuit is closed

Red: one provided for each channel, ON when line fault is detected

Green: one provided for power indication

Power requirement, Vs

52mA at 24V dc

62mA at 20V dc

42mA at 35V dc

Power dissipation within unit

1.25W at 24V

1.5W at 35V

Isolation

250V ac between safe and hazardous area circuits

Safety description for each channel

10.5V, 800 Ω , 14mA

FM entity parameters

Each channel without line fault detection:

$V_{OC} = 10.5$ V dc, $I_{SC} = 14$ mA, $C_a = 2.4$ μ F, $L_a = 165$ mH

Each channel with earth leakage detection:

$V_t = 17.4$ V dc, $I_t = 14$ mA, $C_a = 0.36$ μ F, $L_a = 165$ mH

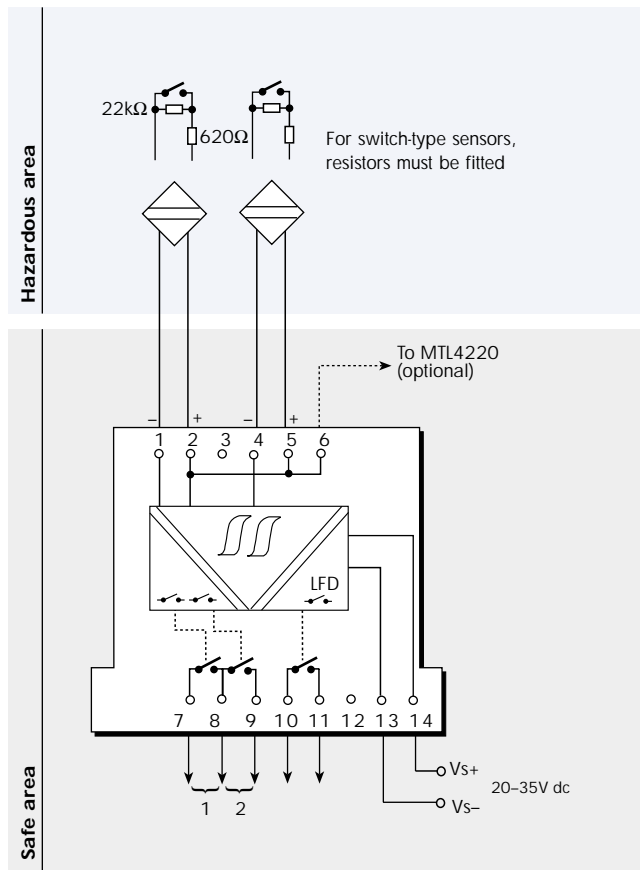

Terminal	Function
1	Input 1 -ve
2	Input 1 +ve
4	Input 2 -ve
5	Input 2 +ve
6	Optional link to MTL4220
7,8	Output 1
8,9	Output 2
10,11	Line fault signal
13	Supply -ve
14	Supply +ve



EUROPE (EMEA)
AMERICAS
ASIA PACIFIC
E-mail: enquiry@mtl-inst.com

Tel: +44 (0)1582 723633
Tel: +1 603 926 0090
Tel: +65 487 7887
Web site: www.mtl-inst.com

Fax: +44 (0)1582 422283
Fax: +1 603 926 1899
Fax: +65 487 7997

MTL4021 SOLENOID/ ALARM DRIVER



The MTL4021 enables an on/off device in a hazardous area to be controlled by a volt-free contact or logic signal in the safe area. It can drive loads such as solenoids, alarms, LEDs and other low power devices that are certified as intrinsically safe or are classified as non-energy storing simple apparatus. By connecting a second safe-area switch or logic signal, the output can be disabled to enable, for example, a safety system to override a control signal. Earth fault detection can be provided by connecting an MTL4220 earth leakage detector to terminal 6.

SPECIFICATION

See also common specification, cable parameters and approvals

Number of channels

One

Location of load

Zone 0, IIC, T4-6 hazardous area if suitably certified
Div.1, Group A, hazardous location

Minimum output voltage

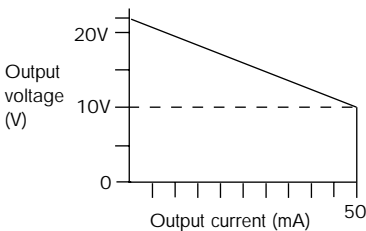

Equivalent output circuit

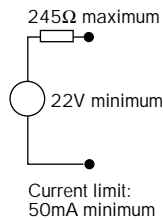

Maximum output voltage

25.5V from 232Ω

Output ripple

<0.5% of maximum output, peak-to-peak

Control input

Suitable for switch contacts, an open collector transistor or logic drive

0 = input switch closed, transistor on or <1.4V applied across terminals 10 & 11

1 = input switch open, transistor off or >4.5V applied across terminals 10 & 11

Override input

An open collector transistor or a switch connected across terminals 8 and 9 can be used to turn the output off whatever the state of the control input

0 = transistor on or switch closed

1 = transistor off or switch open

Control and override inputs

Control input	Override input	Output state
0	0	off
0	1	on
1	0	off
1	1	off

Response time

Output within 10% of final value within 100ms

No-fail earth fault protection

Enabled by connecting terminal 6 to an MTL4220 earth leakage detector

Fault on either line proclaimed: unit continues working

LED indicators

Amber: one provided for status, ON when output circuit is active

Green: one provided for power indication

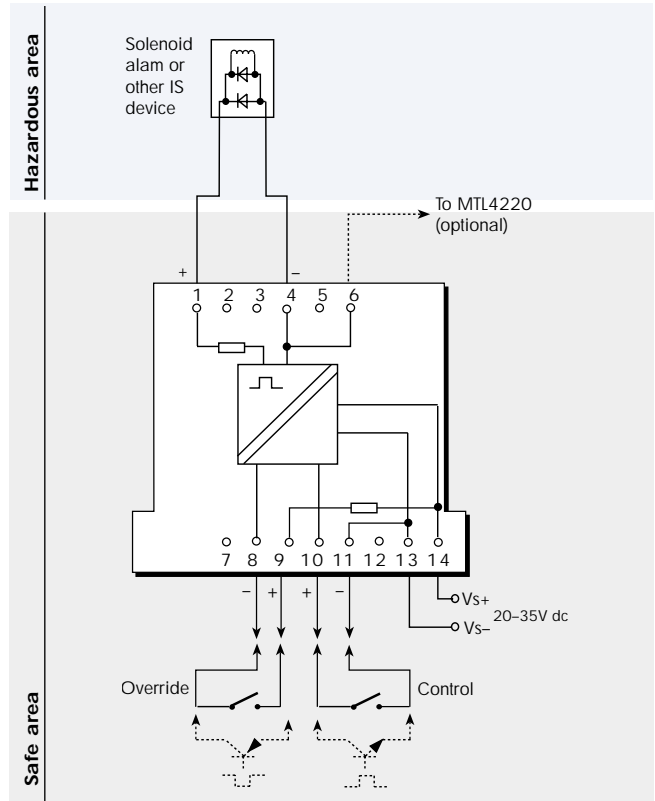

Terminal	Function
1	Output +ve
4	Output -ve
6	Optional link to MTL4220
8	Override -ve
9	Override +ve
10	Control +ve
11	Control -ve
13	Supply -ve
14	Supply +ve

Power requirement, Vs

100mA at 24V dc

120mA at 20V dc

75mA at 35V dc

Power dissipation within unit

1.3W with typical solenoid valve, output on

1.9W worst case

Isolation

250V ac between safe- and hazardous-area circuits

Safety description

25.5V, 232Ω, 110mA

FM entity parameters

$V_{OC} = 25.5V$ dc, $I_{SC} = 110mA$, $C_a = 0.17\mu F$, $L_a = 3mH$



EUROPE (EMEA)
AMERICAS
ASIA PACIFIC
E-mail: enquiry@mtl-inst.com

Tel: +44 (0)1582 723633
Tel: +1 603 926 0090
Tel: +65 487 7887
Web site: www.mtl-inst.com

Fax: +44 (0)1582 422283
Fax: +1 603 926 1899
Fax: +65 487 7997

MTL4021S

SOLENOID/ALARM DRIVER

with 24V logic override facility



The MTL4021S enables an on/off device in a hazardous area to be controlled by a volt-free contact or logic signal in the safe area. It can drive loads such as solenoids, alarms, LEDs and other low power devices that are certified as intrinsically safe or are classified as non-energy storing simple apparatus. Provided that 24V dc is applied to the override input, the solenoid/alarm can be operated by the control input. However, if the 24V dc signal is removed, the solenoid/alarm is turned off. Earth fault detection can be provided by connecting an MTL4220 earth leakage detector to terminal 6.

SPECIFICATION

See also common specification, cable parameters and approvals

Number of channels

One

Location of load

Zone 0, IIC, T4-6 hazardous area if suitably certified
Div.1, Group A, hazardous location

Minimum output voltage

Equivalent output circuit

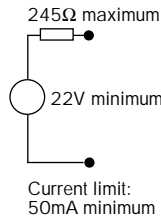
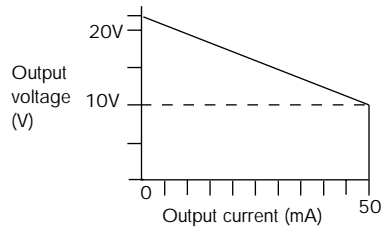

Maximum output voltage

25.5V from 232Ω

Output ripple

<0.5% of maximum output, peak-to-peak

Control input

Suitable for switch contacts, an open collector transistor or logic drive

0 = input switch closed, transistor on or <1.4V applied across terminals 10 & 11

1 = input switch open, transistor off or >4.5V applied across terminals 10 & 11

Override input

A 24V logic signal applied across terminals 8 and 9 allows the solenoid/alarm to be operated by the control input. If it is disconnected, the solenoid/alarm is off.

0 = <2.0V applied across terminals 8 & 9

1 = >9.0V applied across terminals 8 & 9
(nominal switching point 4.5V)

Control and override inputs

Control input	Override input	Output state
0	0	off
0	1	on
1	0	off
1	1	off

Response time

Output within 10% of final value within 100ms

No-fail earth fault protection

Enabled by connecting terminal 6 to an MTL4220 earth leakage detector

Fault on either line proclaimed: unit continues working

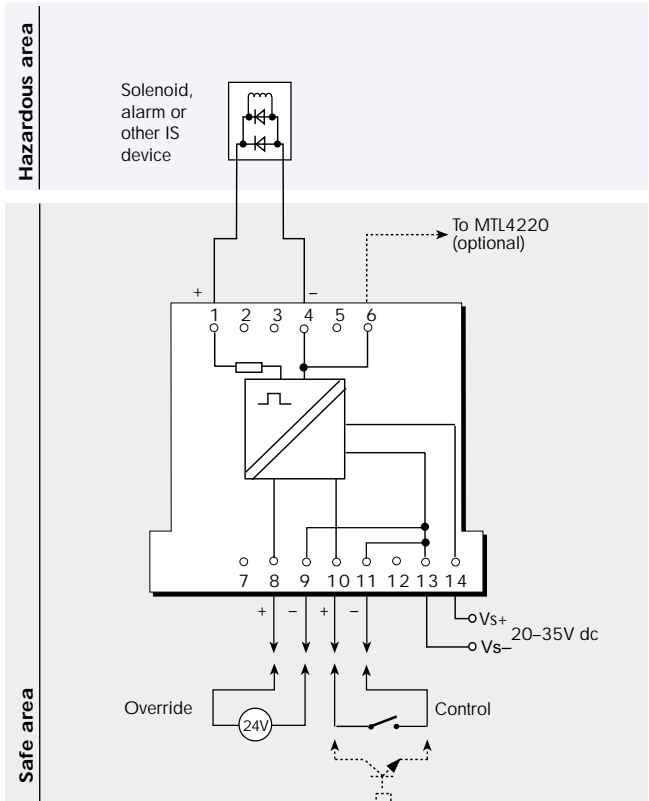

Terminal	Function
1	Output +ve
4	Output -ve
6	Optional link to MTL4220
8	Override +ve
9	Override -ve
10	Control +ve
11	Control -ve
13	Supply -ve
14	Supply +ve

LED indicators

Amber: one provided for status, ON when output circuit is active
Green: one provided for power indication

Power requirement, Vs

100mA at 24V dc

120mA at 20V dc

75mA at 35V dc

Power dissipation within unit

1.3W with typical solenoid valve, output on

1.9W worst case

Isolation

250V ac between safe- and hazardous-area circuits

Safety description

25.5V, 232Ω, 110mA

FM entity parameters

$V_{OC} = 25.5V$ dc, $I_{SC} = 110mA$, $C_a = 0.17\mu F$, $L_a = 3mH$



MTL4023 SOLENOID ALARM DRIVER

with line fault detection



With the MTL4023 interface, an on/off device in a hazardous area can be controlled by a volt-free contact or logic signal in the safe area. It is suitable for driving loads such as solenoids. Line fault detection (LFD), which operates irrespective of the output state, is signalled by a safe-area solid-state switch which de-energises if a field line is open or short-circuited. Earth fault detection can be provided by connecting an MTL4220 earth leakage detector to terminal 6.

SPECIFICATION

See also common specification, cable parameters and approvals

Number of channels

One

Location of load

Zone 0, IIC, T4–6 hazardous area if suitably certified
Div. 1, Group A, hazardous location

Minimum output voltage

Equivalent output circuit

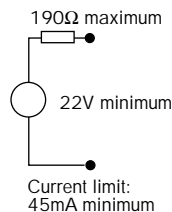
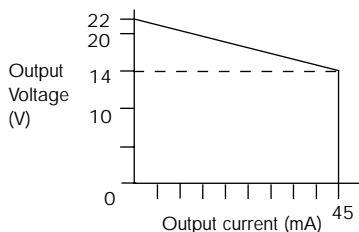

Maximum output voltage

25V from 170Ω

Output ripple

< 0.5% of maximum output, peak to peak

Control input

Suitable for switch contacts, an open collector transistor or logic drive

Output turns on if input switch closed, transistor on or <1.4V applied across terminals 10 & 11

Output turns off if input switch open, transistor off or >4.5V applied across terminals 10 & 11

Response time

Output within 10% of final value within 100ms

Line fault detection (LFD)*

Open or short circuit in field cabling de-energises solid state line fault signal (MTL4023R transistor is energised when line fault is detected)

LFD is operational irrespective of output state provided that the field circuit impedance is normally >50Ω and <7kΩ. Output off-state LFD current normally <5mA.

Line fault signal characteristics

Maximum off-state voltage: 35V
Maximum off-state leakage current: 10μA
Maximum on-state voltage drop: 2V
Maximum on-state current: 50mA

Note: LFD signal is Zener-diode protected against inductive loads

'No-fail' earth fault protection

Enabled by connecting terminal 6 to an MTL4220 earth leakage detector

Fault on either line proclaimed: unit continues working

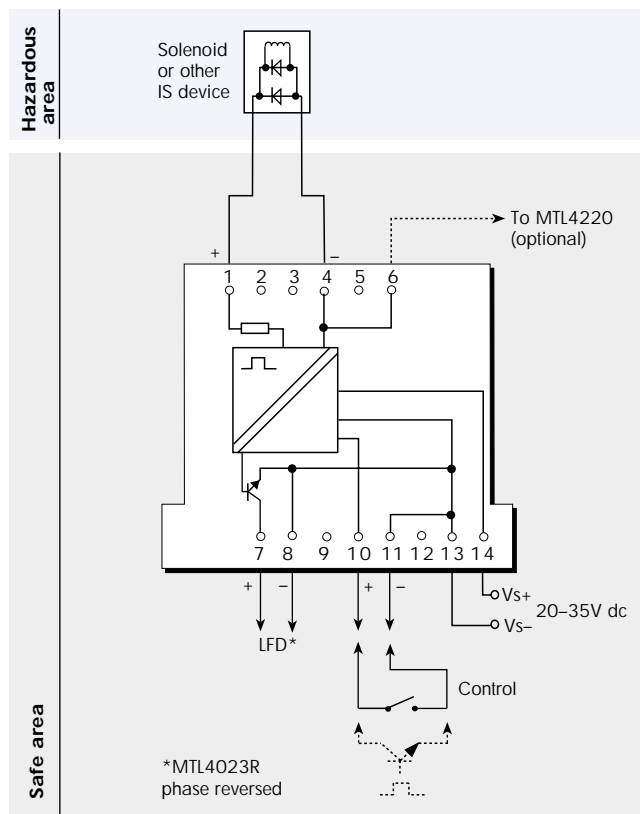

Terminal	Function
1	Output +ve
4	Output -ve
6	Optional link to MTL4220
7	Line fault signal +ve
8	Line fault signal -ve
10	Control +ve
11	Control -ve
13	Supply -ve
14	Supply +ve

LED indicators

Amber: one provided for status, ON when output circuit is active
Red: one provided for line fault detection, ON when line fault is detected

Green: one provided for power indication

Power requirements, Vs

100mA at 24V dc
130mA max at 20V dc
90mA at 35V dc

Power dissipation within unit

1.2W with typical solenoid valve, output on
2.0W worst case

Isolation

250V ac between safe- and hazardous-area circuits

Safety description

25V, 170Ω, 147mA, $U_m=250V$ rms or dc

FM entity parameters

Without earth leakage detection:
 $V_{OC} = 25V$ dc, $I_{SC} = 147mA$, $C_a = 0.17\mu F$, $L_a = 1.6mH$
With earth leakage detection:
 $V_t = 31.9V$ dc, $I_t = 147mA$, $C_a = 0.09\mu F$, $L_a = 1.6mH$



MTL4024

SOLENOID/ALARM DRIVER

loop powered, for 24V systems



The MTL4024 enables an on/off device in a hazardous area to be controlled by a 24V signal in the safe area. It can drive loads such as solenoids, alarms, LEDs and other low-power devices that are certified as intrinsically safe or are classified as non-energy-storing simple apparatus. Provided that 24V dc is applied to the override input, the solenoid/alarm can be operated by a voltage change in the safe area. However, if the 24V dc override signal is removed, the solenoid/alarm is turned off. Earth fault detection can be provided by connecting an MTL4220 earth leakage detector to terminal 6. The MTL4024R is functionally identical to the MTL4024, but has pin 11 connected internally to pin 13.

SPECIFICATION

See also common specification, cable parameters and approvals

Number of channels

One

Location of signal load

Zone 0, IIC, T4-6 hazardous area if suitably certified
Div. 1, Group A, hazardous location

Minimum output voltage

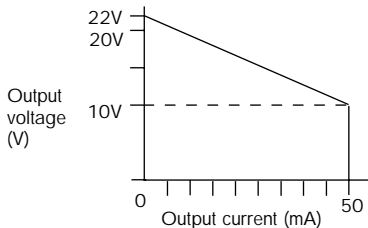

Equivalent output circuit

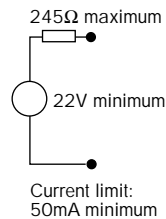

Maximum output voltage

25.5V from 232Ω

Output ripple

<0.5% of maximum output, peak-to-peak

Override input

A 24V signal applied across terminals 8 and 9 allows the solenoid/alarm to be operated by the supply across terminals 10 and 11. If the 24V signal is disconnected, the solenoid/alarm is off.

Voltage across terminals 8 and 9	State of solenoid/alarm
<2.0V	Off
>9.0V	Controlled by supply across terminals 10 and 11
>2.0V but <9.0V	Undetermined

Input impedance at terminal 8

Typically 10kΩ

Response time

Output within 10% of final value within 100ms

'No-fail' earth fault protection

Enabled by connecting terminal 6 to an MTL4220 earth leakage detector

Fault on either line proclaimed: unit continues working

LED indicators

Amber: one provided for status, ON when output circuit is active
Green: one provided for drive status ON when supply is connected

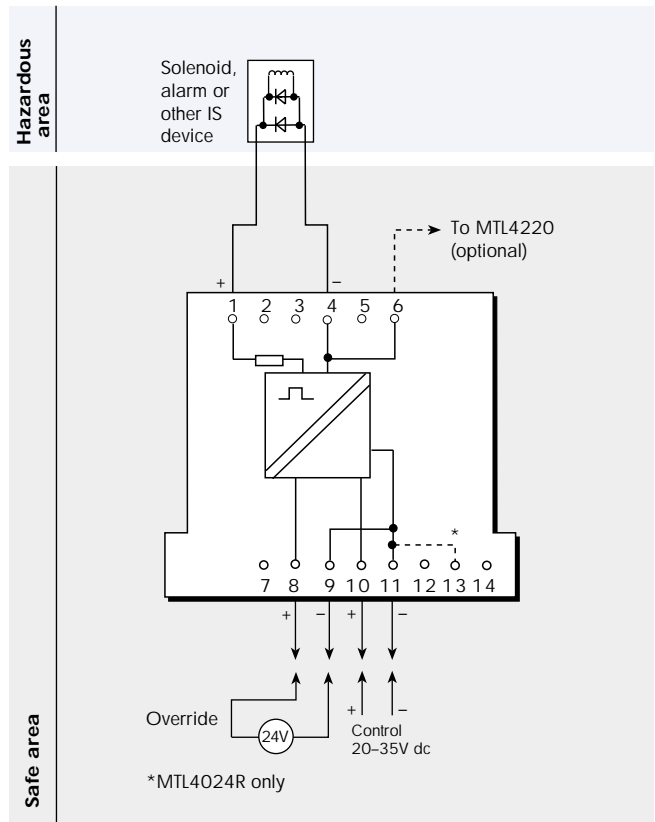

Terminal	Function
1	Output +ve
4	Output -ve
6	Optional link to MTL4220
8	Override +ve
9	Override -ve
10	Supply +ve
11	Supply -ve

Power requirement (control)

100mA at 24V dc

120mA at 20V dc

75mA at 35V dc

Power dissipation within unit

1.3W at 24V with typical solenoid valve, output on

1.9W worst case

Isolation

250V ac between safe- and hazardous-area circuits

Safety description

25.5V, 232Ω, 110mA

FM entity parameters

$V_{OC} = 25.5V$ dc, $I_{SC} = 110mA$, $C_a = 0.17\mu F$, $L_a = 3mH$



MTL4025

SOLENOID/ALARM DRIVER

low current output



The MTL4025 enables an on/off device in a hazardous area to be controlled by a volt-free contact or logic signal in the safe area. It can drive any loads such as solenoids, alarms, and LEDs that are certified as intrinsically safe or are classified as non-energy-storing simple apparatus. It also acts as a power supply for PLMS GD4001 and GD4002 gas detectors. For full configuration details please refer to the PLMS installation instructions. Earth fault detection can be provided by connecting an MTL4220 earth leakage detector to terminal 6.

SPECIFICATION

See also common specification, cable parameters and approvals

Number of channels

One

Location of load

Zone 0, IIC, T4-6 hazardous area if suitably certified
Div.1, Group A, hazardous location

Minimum output voltage Equivalent output circuit

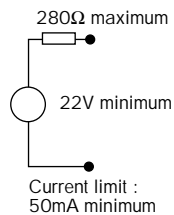
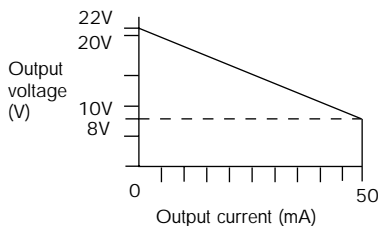

Maximum output voltage

25V from 269Ω

Output ripple

<0.5% of maximum output, peak-to-peak

Control input

Suitable for switch contacts, an open collector transistor or logic drive

0 = input switch closed, transistor on or <1.4V applied across terminals 10 & 11

1 = input switch open, transistor off or >4.5V applied across terminals 10 & 11

Override input

An open collector transistor or a switch connected across terminals 8 and 9 can be used to turn the output off whatever the state of the control input

0 = transistor on or switch closed

1 = transistor off or switch open

Control and override inputs

Control input	Override input	Output state
0	0	off
0	1	on
1	0	off
1	1	off

Response time

Output within 10% of final value within 100ms

'No-fail' earth fault protection

Enabled by connecting terminal 6 to an MTL4220 earth leakage detector

Fault on either line proclaimed: unit continues working

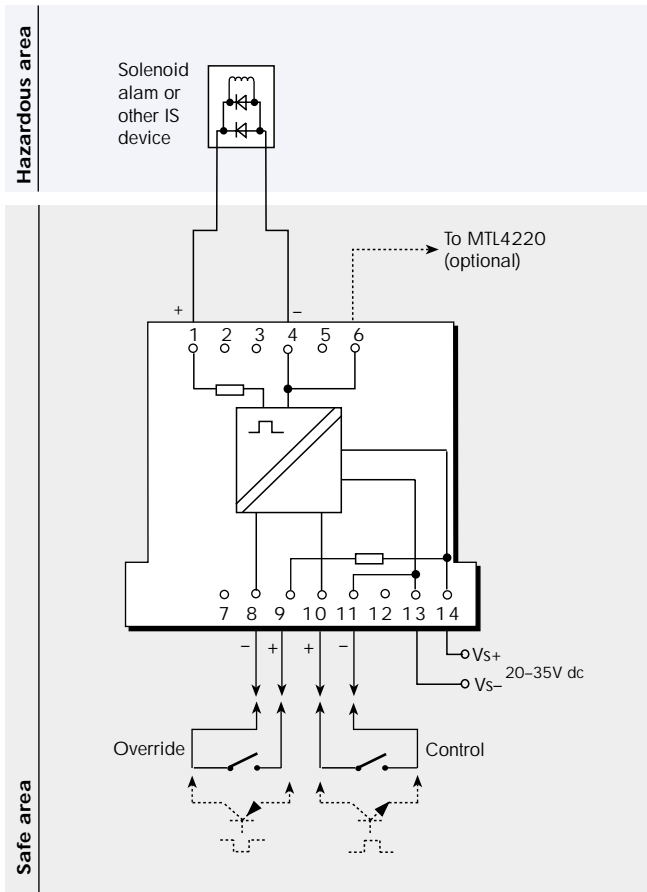

Terminal	Function
1	Output +ve
4	Output -ve
6	Optional link to MTL4220
8	Override -ve
9	Override +ve
10	Control +ve
11	Control -ve
13	Supply -ve
14	Supply +ve

LED indicators

Amber: one provided for status, ON when output circuit is active
Green: one provided for power indication

Power requirement, Vs

100mA at 24V dc

120mA at 20V dc

75mA at 35V dc

Power dissipation within unit

1.1W with typical solenoid valve, output on

1.9W worst case

Isolation

250V ac between safe- and hazardous-area circuits

Safety description

25V, 269Ω, 93mA

FM entity parameters

$V_{OC} = 25V$ dc, $I_{SC} = 93mA$, $C_A = 0.17\mu F$, $L_A = 4.2mH$



MTL4031 VIBRATION TRANSDUCER INTERFACE



The MTL4031 is for use with vibration sensors mounted in a hazardous area and connected into monitoring equipment for use with rotating machinery. The interface is compatible with both 3-wire eddy probes and high frequency accelerometers.

SPECIFICATION

See also common specification, cable parameters and approvals

Number of channels

One

Location of signal source

Zone 0, IIC, T4-6 hazardous area if suitably certified
Div. 1, Group A, hazardous location

Transducer supply voltage (terminals 2 and 6)

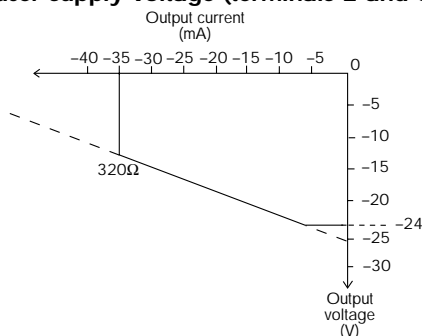

Signal range (terminals 5 and 6, 7 and 8)

Minimum: -20V
Maximum: -0.5V
for dc transfer error < ±100mV

Signal input impedance (terminals 5 and 6)

10kΩ -1%, +2%

Signal output impedance (terminals 7 and 8)

<20Ω

DC transfer accuracy at 20°C

< ±100mV

AC transfer accuracy at 20°C

0Hz to 1kHz: ±1%
1kHz to 10kHz: -5% to +1%
10kHz to 20kHz: -10% to +1%

Temperature coefficient

50ppm/°C (10 to 65°C)
100ppm/°C (-20 to 10°C)

Voltage bandwidth

-3dB at 43kHz (typical)

Phase delay

Less than 14μs, equivalent to:

-1° at 200Hz
-3° at 600Hz
-5° at 1kHz
-50° at 10kHz
-100° at 20kHz

LED indicator

Green: one provided for power indication

Power requirement, Vs, with 22mA transducer load

80mA at 24V dc
88mA at 20V dc
63mA at 35V dc

Power dissipation within unit

<1.7W

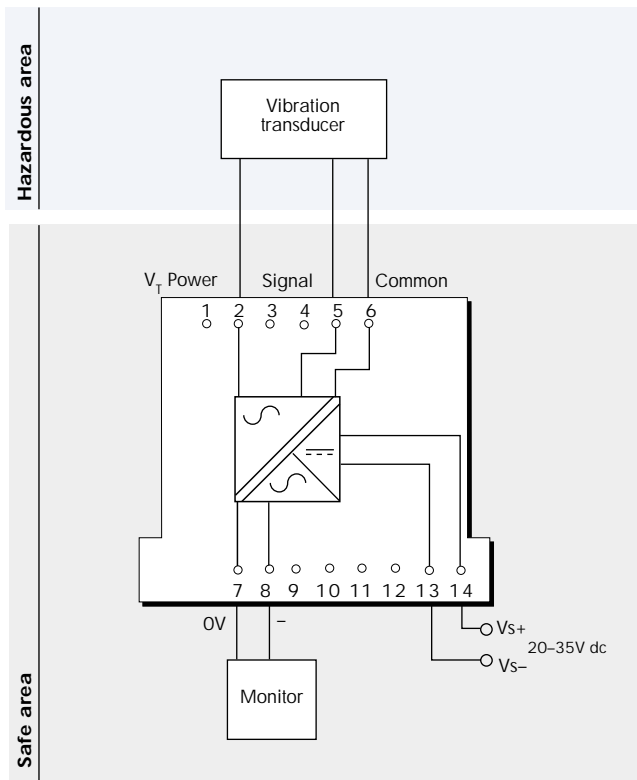

Terminal	Function
2	Supply to hazardous area
5	Signal input
6	Common (0V)
7	Signal (0V)
8	Signal output -ve
13	Supply -ve
14	Supply +ve

Isolation

250V ac between input, power and output circuits

Safety description

Terminals 2 to 6
26.6V, 94mA, 0.66Ω

Terminals 5 to 6
Non-energy-storing apparatus ≤1.2V, ≤0.1A, ≤20μJ, and ≤25mW



MTL4032 PULSE ISOLATOR



The MTL4032 isolates pulses from a switch, proximity detector, current pulse transmitter or voltage pulse transmitter located in a hazardous area. It is ideal for applications involving high pulse rates and fast response times.

SPECIFICATION

See also common specification, cable parameters and approvals

Number of channels

One, fully floating

Sensor type

Switch or proximity detector (NAMUR/DIN 19234)
2- or 3-wire voltage or pulse transmitter

Location of switch

Zone 0, IIC, T6 hazardous area
Div. 1, Group A, hazardous location

Location of proximity detector or transmitter

Zone 0, IIC, T4–T6 if suitably certified
Div.1, Group A, hazardous location

Input

Switch input:

Output ON if switch is closed
Output OFF if switch is open

Proximity detector input:

Excitation: 7.0 to 9.0V dc from 1k Ω nominal
Output ON if input >2.1mA* (<2k Ω)
Output OFF if input <1.2mA* (>10k Ω)
Switching hysteresis: 0.2mA (650 Ω) nominal
*NAMUR and DIN19234 standards for proximity detectors

Current pulse input:

Transmitter supply: 16.5V dc at 20mA
Short circuit current: 24mA
Output ON if input >9.0mA
Output OFF if input <7.0mA
Switching hysteresis: 0.5mA

Voltage pulse input

Input impedance: >10k Ω
Switching point voltage (V_{sp}): 3, 6, or 12V nominal (selectable by switch on top of unit)
Output ON if input >V_{sp}
Output OFF if input <V_{sp}
Switching hysteresis: 100mV + (0.1 x V_{sp}) typical

Pulse width

High: 10 μ s min
Low: 10 μ s min

Frequency range

0–50kHz

Output characteristics

Maximum off-state voltage: 35V
Maximum off-state leakage current: 10 μ A
Maximum on-state voltage drop: 1 + (0.1x current in mA) V
Maximum on-state current: 50mA
Output OFF if supply fails
Note: the output is zener diode protected against inductive loads

LED indicators

Amber: one provided for input, ON when output circuit is ON
Green: one provided for power indication

Power requirement

65mA at 24V dc
70mA at 20V dc
55mA at 35V dc

Power dissipation within unit

1.35W maximum at 24V
1.75W maximum at 35V

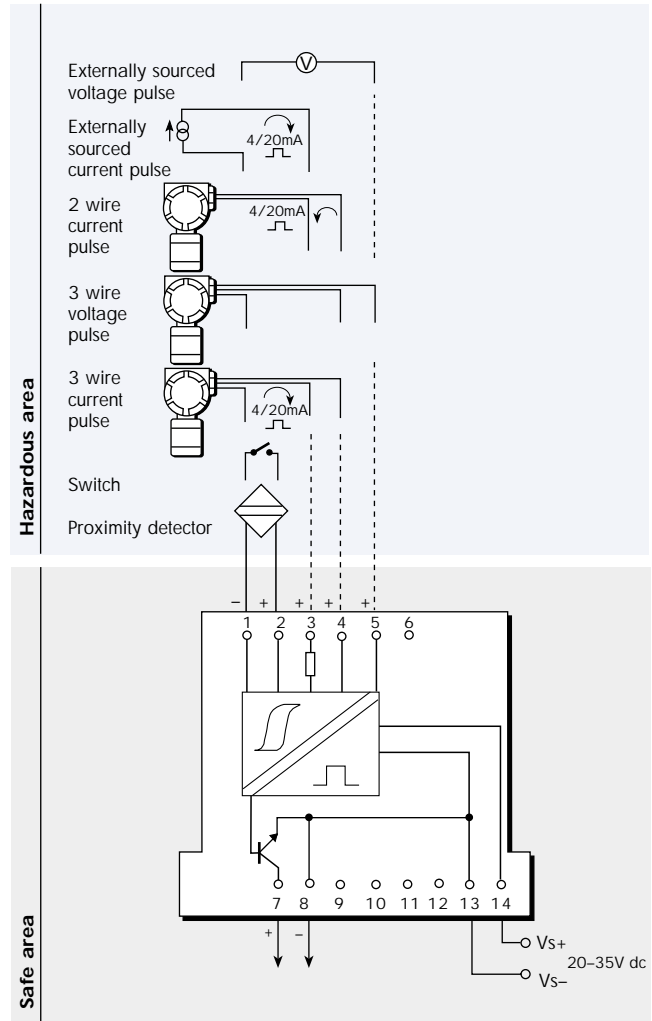

Terminal	Function
1	Common input -ve
2	Switch/proximity input +ve
3	Current pulse input +ve
4	Tx supply +ve
5	Voltage pulse input +ve
7	Pulse output +ve
8	Pulse output -ve
13	Supply -ve
14	Supply +ve

Isolation

250V ac between safe- and hazardous-area circuits

Safety description

Terminals 2 to 1

10.5V, 800 Ω , 14mA

Terminals 4 to 3 and 1

28V, 300 Ω , 93mA

Terminals 3 to 1

Non-energy storing apparatus $\leq 1.2V$, $\leq 0.1A$, $\leq 20\mu J$ and $\leq 25mW$; can be connected without further certification into any IS loop with open-circuit voltage not more than 28V

Terminals 5 to 4 and 1

V_{max} $\leq 28V$, I_{max} $\leq 94mA$, P_{max} $\leq 0.66W$

FM entity parameters

Terminals 1, 4 and 5

V_t = 27.6V, I_t = 94mA, C_a = 0.12 μ F, L_a = 4.2mH

Terminals 1, 2

V_{OC} = 10.5V, I_{SC} = 13mA, C_a = 2.4 μ F, L_a = 200mH

Terminals 1, 3, 4

V_t = 27.6V, I_t = 155mA, C_a = 0.12 μ F, L_a = 1.57mH

Terminals 1, 3

V_{OC} = 1.1V, I_{SC} = 51mA, C_a = 1000 μ F, L_a = 13.8mH



MTL4041A CURRENT REPEATER

4/20mA passive input for smart transmitters



The MTL4041A provides an input for separately powered 4/20mA transmitters and also allows bi-directional transmission of digital communication signals superimposed on the 4/20mA loop current, so that the transmitter can be interrogated either from the operator station or by a hand-held communicator (HHC).

SPECIFICATION

See also common specification, cable parameters and approvals

Number of channels

One

Location of transmitter

Zone 0, IIC, T4-6 hazardous area if suitably certified
Div.1, Group A, hazardous location

Input impedance for HART® signals

at terminals 5, 6: >230Ω

Maximum input volt drop

at terminals 5, 6: <6.2V

i.e. a transmitter load of 310Ω at 20mA

Input and output signal range

4 to 20mA

Over-/under-range

1.0mA to 21.5mA

Digital signal bandwidth

50Hz to 8kHz

Safe-area circuit load resistance

Conventional transmitters: 0 to 600Ω

Smart transmitters: 250Ω ±10%

Safe-area circuit output resistance

>1MΩ

Safe-area circuit ripple

< 50µA peak-to-peak up to 80kHz

Transfer accuracy at 20°C

Better than 20µA

Temperature drift

<1µA/°C

Response time

Settles within 200µA of final value after 20ms

LED indicator

Green: one provided for power indication

Power requirement, at 20mA

70mA at 24V

85mA at 20V

50mA at 35V

Power dissipation within unit, at 20mA

1.6W at 24V

1.7W at 35V

Isolation

250V ac between safe- and hazardous-area circuits

Safety description

Terminals 3 to 4 and 5 to 6

8.6V (diode). This voltage must be considered when calculating the load capacitance.

Simple apparatus

Terminals 3 to 4 and 5 to 6 meet clause 5.4 of EN50020 : 1994 and have the following parameters: $U \leq 1.5V$, $I \leq 0.1A$, $P \leq 25mW$. They can be connected without further certification into an IS loop with open circuit voltage of not more than 28V. See certificate for further details.

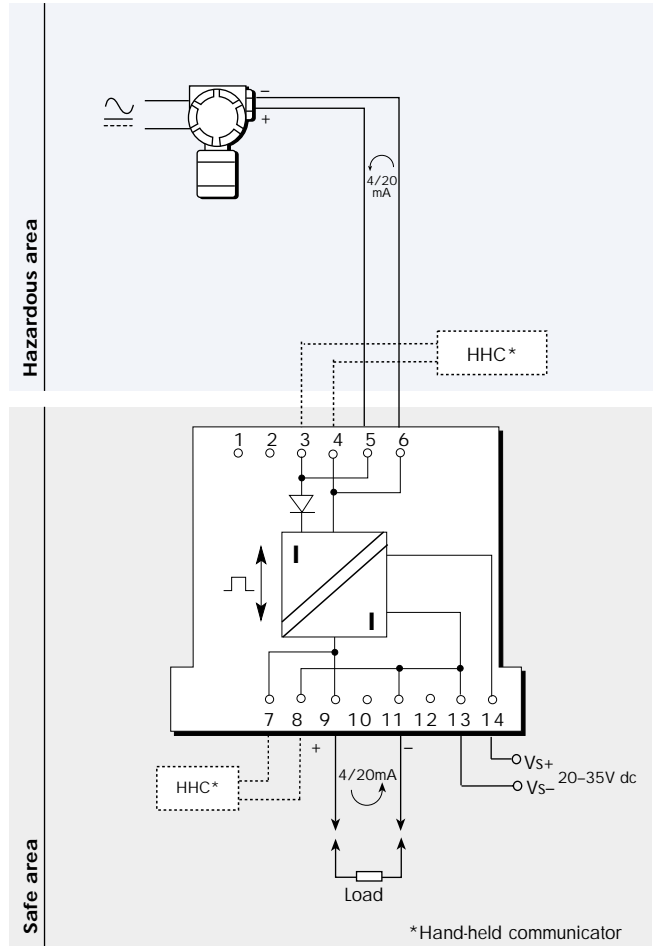

Terminal	Function
3	Optional HHC connection +ve
4	Optional HHC connection -ve
5	Tx signal +ve
6	Tx signal -ve
7	Optional HHC connection +ve
8	Optional HHC connection -ve
9	Output +ve
11	Output -ve
13	Supply -ve
14	Supply +ve

HART® is a registered trademark of HART Communication Foundation



EUROPE (EMEA) Tel: +44 (0)1582 723633 Fax: +44 (0)1582 422283
 AMERICAS Tel: +1 603 926 0090 Fax: +1 603 926 1899
 ASIA PACIFIC Tel: +65 487 7887 Fax: +65 487 7997
 E-mail: enquiry@mtl-inst.com Web site: www.mtl-inst.com

Sept 2002

MTL4041B REPEATER POWER SUPPLY

4/20mA, smart, for 2- or 3-wire transmitters



The MTL4041B provides a fully floating dc supply for energising a conventional 2- or 3-wire 4/20mA transmitter or a 'smart' transmitter located in a hazardous area, and repeats the current in another circuit to drive a safe-area load. For smart transmitters, the unit allows bi-directional transmission of digital communication signals superimposed on the 4/20mA signal so that the transmitter can be interrogated either from the operator station or by a hand-held communicator (HHC). The module can also be used with hazardous-area current sources and some vortex and turbine meters.

SPECIFICATION

See also common specification, cable parameters and approvals

Number of channels

One

Location of transmitter

Zone 0, IIC, T4-6 hazardous area if suitably certified
Div.1, Group A, hazardous location

Voltage available for transmitter and lines

15V minimum at 20mA

Note: maximum open-circuit voltage is 28V

Input and output signal range

4 to 20mA

Over-/under-range

1.0mA to 21.5mA

Digital signal bandwidth

10Hz to 8kHz

Safe-area circuit load resistance

Conventional transmitters: 0 to 650Ω

Smart transmitters: 250Ω ±10%

Safe-area circuit output resistance

>1MΩ

Safe-area circuit ripple

<50μA peak-to-peak up to 80kHz

Transfer accuracy at 20°C

Better than 20μA

Temperature drift

<1μA/°C

Response time

Settles within 200μA of final value within 20ms

LED indicator

Green: one provided for power indication

Power requirement, Vs

65mA at 24V dc

75mA at 20V dc

50mA at 35V dc with 20mA signal

Power dissipation within unit

1.2W at 24V with 20mA signal

1.4W at 35V

Isolation

250V ac between safe- and hazardous-area circuits

Safety description

Terminals 2 to 5 and 6

28V, 300Ω, 93mA

Terminals 5 to 6

Non-energy storing apparatus ≤1.2V, ≤0.1A, ≤20μJ and ≤25mW; can be connected without further certification into any IS loop with open-circuit voltage not more than 28V

Note: Terminals 5 and 6 only support HART® communications in one direction from field device to safe-area connections 9 and 11.

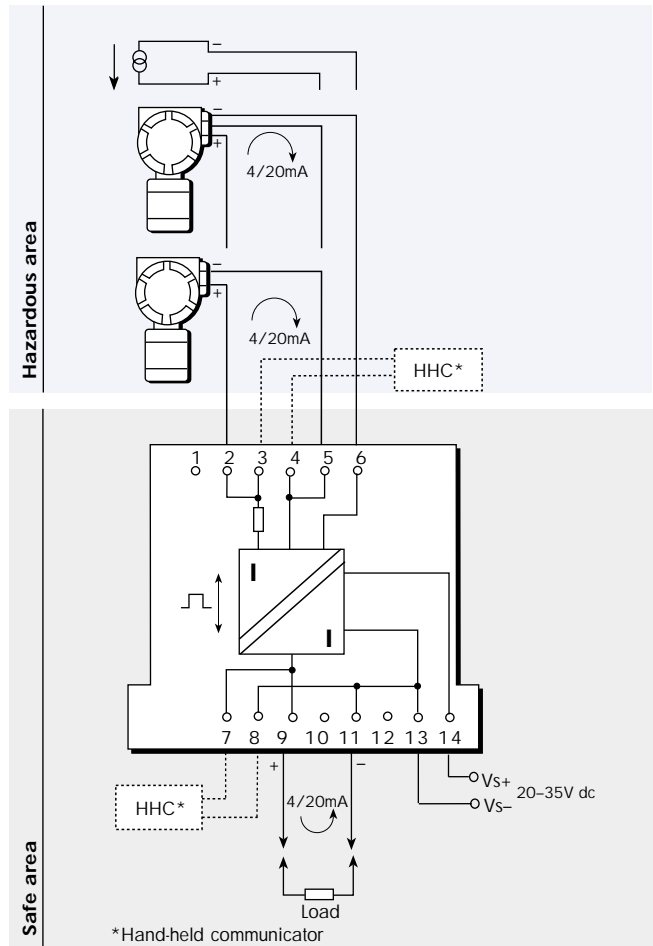

Terminal	Function
2	Tx supply +ve
3	Optional HHC connection +ve
4	Optional HHC connection -ve
5	Current input -ve
6	Common
7	Optional HHC connection +ve
8	Optional HHC connection -ve
9	Output +ve
11	Output -ve
13	Supply -ve
14	Supply +ve

FM entity parameters

Terminals 2, 5, 6

$V_t = 28V$, $I_t = 141mA$, $C_a = 0.13\mu F$, $L_a = 1.94mH$

Terminals 2, 4, 5

$V_t = 28V$, $I_t = 93mA$, $C_a = 0.13\mu F$, $L_a = 4.2mH$

HART® is a registered trademark of HART Communication Foundation



EUROPE (EMEA) Tel: +44 (0)1582 723633 Fax: +44 (0)1582 422283
 AMERICAS Tel: +1 603 926 0090 Fax: +1 603 926 1899
 ASIA PACIFIC Tel: +65 487 7887 Fax: +65 487 7997
 E-mail: enquiry@mtl-inst.com Web site: www.mtl-inst.com

MTL4041P HIGH-POWER REPEATER POWER SUPPLY

4/20mA, smart, for 2- or 3-wire transmitters



The MTL4041P provides a fully floating dc supply for energising a conventional 2- or 3-wire 4/20mA transmitter or a 'smart' transmitter located in a hazardous area, and repeats the current in another circuit to drive a safe-area load. For smart transmitters, the unit allows bi-directional transmission of digital communication signals superimposed on the 4/20mA signal so that the transmitter can be interrogated either from the operator station or by a hand-held communicator (HHC). The module can also be used with hazardous-area current sources. The MTL4041P is a high-power version of the MTL4041B, suitable for all gas groups provided that the field equipment is suitably certified.

SPECIFICATION

See also common specification, cable parameters and approvals

Number of channels

One

Location of transmitter

Zone 0, IIC, T4-6 hazardous area if suitably certified
Div.1, Group A, hazardous location

Voltage available for transmitter and lines

16.3V minimum at 20mA

Note: maximum open-circuit voltage is 28V

Input and output signal range

4 to 20mA

Over-/under-range

1.0mA to 21.5mA

Digital signal bandwidth

10Hz to 8kHz

Safe-area circuit load resistance

Conventional transmitters: 0 to 650Ω

Smart transmitters: 250Ω ±10%

Safe-area circuit output resistance

>1MΩ

Safe-area circuit ripple

<50μA peak-to-peak up to 80kHz

Transfer accuracy at 20°C

Better than 20μA

Temperature drift

<1μA/°C

Response time

Settles within 200μA of final value within 20ms

LED indicator

Green: one provided for power indication

Power requirement, V_s

65mA at 24V dc with 20mA signal

75mA at 20V dc

50mA at 35V dc

Power dissipation within unit

1.2W at 24V with 20mA signal

1.4W at 35V

Isolation

250V ac between safe- and hazardous-area circuits

Safety description

Terminals 2 to 5 and 6

28V, 240Ω, 116.6mA

Terminals 5 to 6

Non-energy storing apparatus ≤1.2V, ≤0.1A, ≤20μJ and ≤25mW; can be connected without further certification into any IS loop with open-circuit voltage not more than 28V

Note: Terminals 5 and 6 only support HART® communications in one direction from field device to safe-area connections 9 and 11.

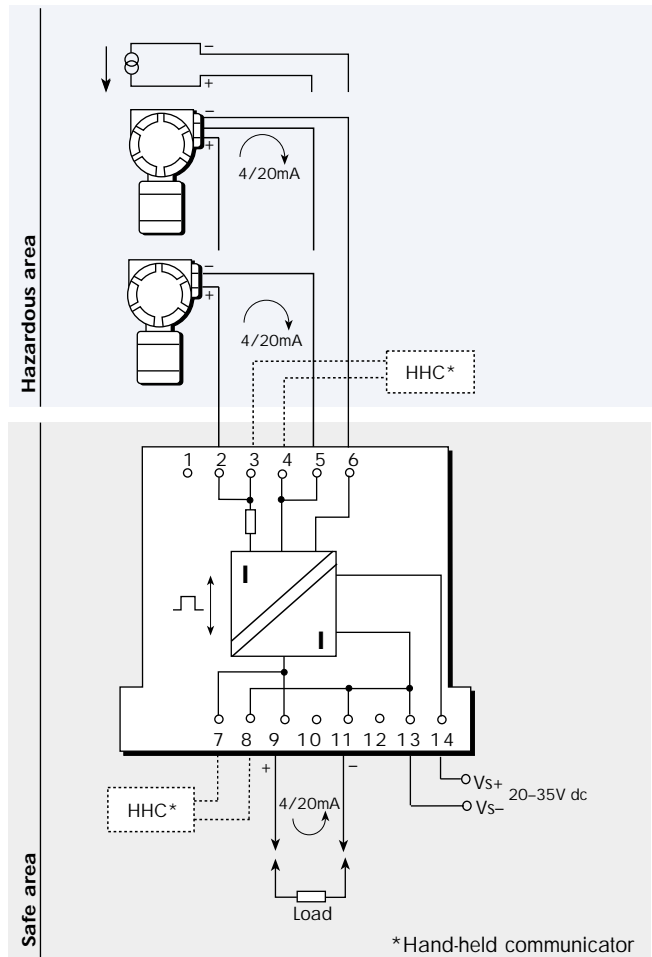

Terminal	Function
2	Tx supply +ve
3	Optional HHC connection +ve
4	Optional HHC connection -ve
5	Current input
6	Common
7	Optional HHC connection +ve
8	Optional HHC connection -ve
9	Output +ve
11	Output -ve
13	Supply -ve
14	Supply +ve

FM entity parameters

Terminals 2 and 5

V_{OC} = 28V dc, I_{SC} = 118mA, C_A = 0.14μF, L_A = 2.76mH

Terminals 2, 3, 4, 5 and 6

V_t = 28V dc, I_t = 166mA, C_A = 0.14μF, L_A = 1.41mH

HART® is a registered trademark of HART Communication Foundation



EUROPE (EMEA) Tel: +44 (0)1582 723633 Fax: +44 (0)1582 422283
AMERICAS Tel: +1 603 926 0090 Fax: +1 603 926 1899
ASIA PACIFIC Tel: +65 487 7887 Fax: +65 487 7997
E-mail: enquiry@mtl-inst.com Web site: www.mtl-inst.com

Sept 2002

MTL4041T REPEATER POWER SUPPLY

**4/20mA for 2- or 3-wire transmitters
using long field lines**



The MTL4041T provides a fully floating dc supply for energising a conventional 2- or 3-wire 4/20mA transmitter located in a hazardous area, and repeats the current in another circuit to drive a safe-area load. The reduced maximum open-circuit voltage permits the use of longer field lines compared to MTL4041B.

SPECIFICATION

See also common specification, cable parameters and approvals

Number of channels

One

Location of transmitter

Zone 0, IIC, T4-6 hazardous area if suitably certified
Div.1, Group A, hazardous location

Voltage available for transmitter and lines

16V minimum at 20mA

Note: maximum open-circuit voltage is 22V

Input and output signal range

4 to 20mA

Over-/under-range

1.0mA to 21.5mA

Safe-area circuit load resistance

0 to 650Ω

Safe-area circuit output resistance

>1MΩ

Safe-area circuit ripple

<50μA peak-to-peak up to 80kHz

Transfer accuracy at 20°C

Better than 20μA

Temperature drift

<1μA/°C

Response time

Settles within 200μA of final value within 20ms

LED indicator

Green: one provided for power indication

Power requirement, Vs

65mA at 24V dc

75mA at 20V dc

50mA at 35V dc with 20mA signal

Power dissipation within unit

1.2W at 24V with 20mA signal

1.4W at 35V

Isolation

250V ac between safe- and hazardous-area circuits

Safety description

Terminals 2 & 3 to 4 & 5

22V, 134Ω, 165mA

Terminals 4 & 5 to 6

Non-energy storing apparatus $\leq 1.2V$, $\leq 0.1A$, $\leq 20\mu J$ and $\leq 25mW$; can be connected without further certification into any IS loop with parameters $U_o = 30V$, $I_o = 121mA$, source resistance U_o/I_o

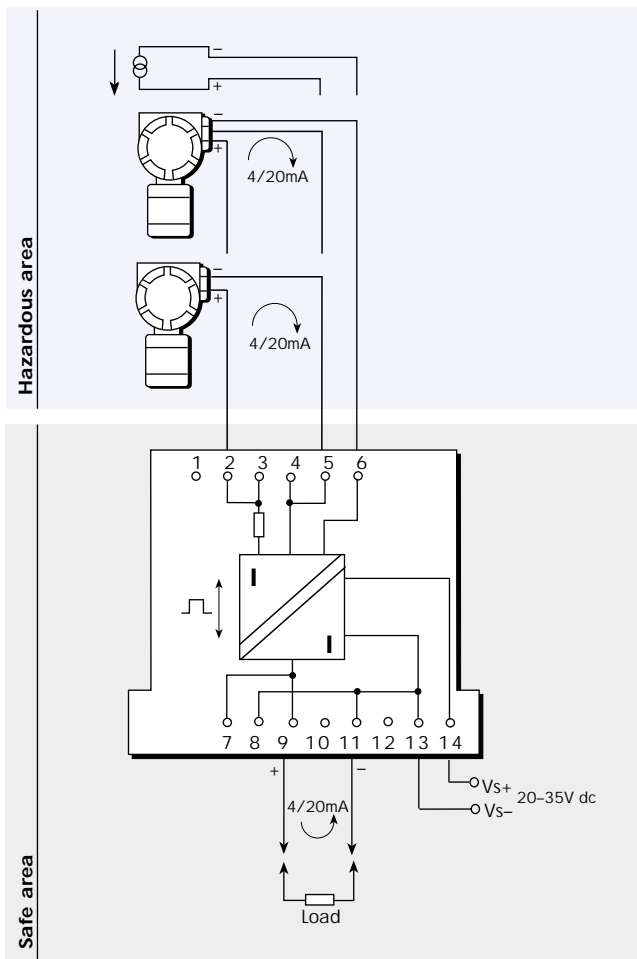

Terminal	Function
2, 3	Tx supply +ve
4, 5	Current input
6	Common
7, 9	Output +ve
8, 11	Output -ve
13	Supply -ve
14	Supply +ve



EUROPE (EMEA)
AMERICAS
ASIA PACIFIC
E-mail: enquiry@mtl-inst.com

Tel: +44 (0)1582 723633
Tel: +1 603 926 0090
Tel: +65 487 7887
Web site: www.mtl-inst.com

Fax: +44 (0)1582 422283
Fax: +1 603 926 1899
Fax: +65 487 7997

MTL4042 REPEATER POWER SUPPLY IIB

4/20mA, for 2-wire transmitters



The MTL4042 provides a fully-floating dc supply for energising a conventional 2-wire 4/20mA transmitter located in a hazardous area, and repeats the current in another circuit to drive a safe-area load.

SPECIFICATION

See also common specification, cable parameters and approvals

Number of channels

One

Location of transmitter

Zone 0, IIB, T4-6 hazardous area if suitably certified
Div. 1, Group C, hazardous location

Voltage available for transmitter and lines

18.0V minimum at 20mA

Note: maximum open-circuit voltage is 28V

Input and output signal range

4 to 20mA

Over-/under-range

1.0mA to 21.5mA

Safe-area circuit load resistance

Conventional transmitters: 0 to 650Ω

Safe-area circuit output resistance

>1MΩ

Safe-area circuit ripple

<50μA peak-to-peak up to 80kHz

Transfer accuracy at 20°C

Better than 20μA

Temperature drift

<1μA/°C

Response time

Settles within 200μA of final value within 20ms

LED indicator

Green: one provided for power indication

Power requirement, Vs

65mA at 24V dc

75mA at 20V dc

50mA at 35V dc

Power dissipation within unit

1.2W at 24V with 20mA signal

1.4W at 35V

Isolation

250V ac between safe- and hazardous-area circuits

Safety description

Terminals 2 to 5

28V, 150Ω, 187mA, $U_m = 250V$ rms or dc

FM entity parameters

$V_{OC} = 28V$ dc, $I_{SC} = 185.5mA$, $C_a = 0.39\mu F$, $L_a = 4.5mH$

Hazardous area

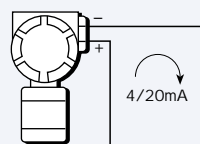

Safe area

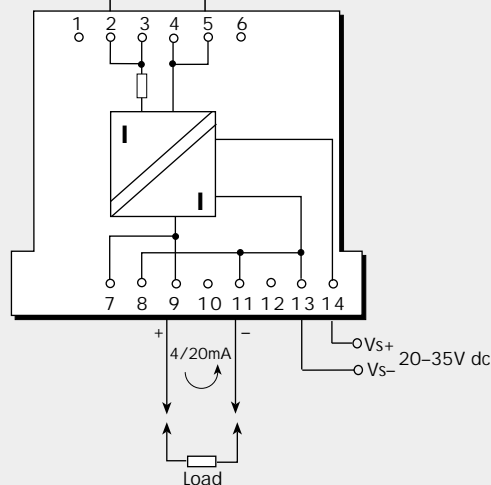

Terminal	Function
2	Tx supply +ve
3	Optional connection +ve
4	Optional connection -ve
5	Current input -ve
7	Optional connection +ve
8	Optional connection -ve
9	Output +ve
11	Output -ve
13	Supply -ve
14	Supply +ve



EUROPE (EMEA)

Tel: +44 (0)1582 723633

Fax: +44 (0)1582 422283

AMERICAS

Tel: +1 603 926 0090

Fax: +1 603 926 1899

ASIA PACIFIC

Tel: +65 487 7887

Fax: +65 487 7997

E-mail: enquiry@mtl-inst.com Web site: www.mtl-inst.com

MTL4043 REPEATER POWER SUPPLY

4/20mA, HART, current sinking



The MTL4043 provides a fully floating dc supply for energising a conventional 2- or 3-wire 4/20mA transmitter or a 'HART' transmitter located in a hazardous area, and controls the current in another safe area circuit. For HART® transmitters, the unit allows bi-directional transmission of digital communication signals superimposed on the 4/20mA signal so that the transmitter can be interrogated either from the operator station or by a hand-held communicator (HHC). The safe-area connections (terminals 9 and 11) are 'current sinking' making the MTL4043 suitable for use with analogue inputs which act as the current source.

SPECIFICATION

See also common specification, cable parameters and approvals

Number of channels

One

Location of transmitter

Zone 0, IIC, T4-6 hazardous area if suitably certified
Div.1, Group A, hazardous location

Voltage available for transmitter and lines

15V minimum at 20mA

Note: maximum open-circuit voltage is 28V

Input and output signal range

4 to 20mA

Over-/under-range

1.0mA to 21.5mA

Digital signal bandwidth

50Hz to 8kHz

Safe-area load

Source voltage: 30V max

Minimum load resistance: 0Ω at up to 20V source voltage

200Ω at up to 24V source voltage

500Ω at up to 30V source voltage

Load resistance for HART operation: 250Ω ±10%

Safe-area circuit output resistance

>1MΩ

Safe-area circuit ripple

<50μA peak-to-peak up to 80kHz

Transfer accuracy at 20°C

Better than 20μA

Temperature drift

<1μA/°C

Response time

Settles within 200μA of final value within 20ms

LED indicator

Green: one provided for power indication

Power requirement, Vs, with 20mA signal

49mA at 24V dc

57mA at 20V dc

36mA at 35V dc

Power dissipation within unit, with 20mA signal

1.2W at 24V

1.4W at 35V

Isolation

250V ac between safe- and hazardous-area circuits

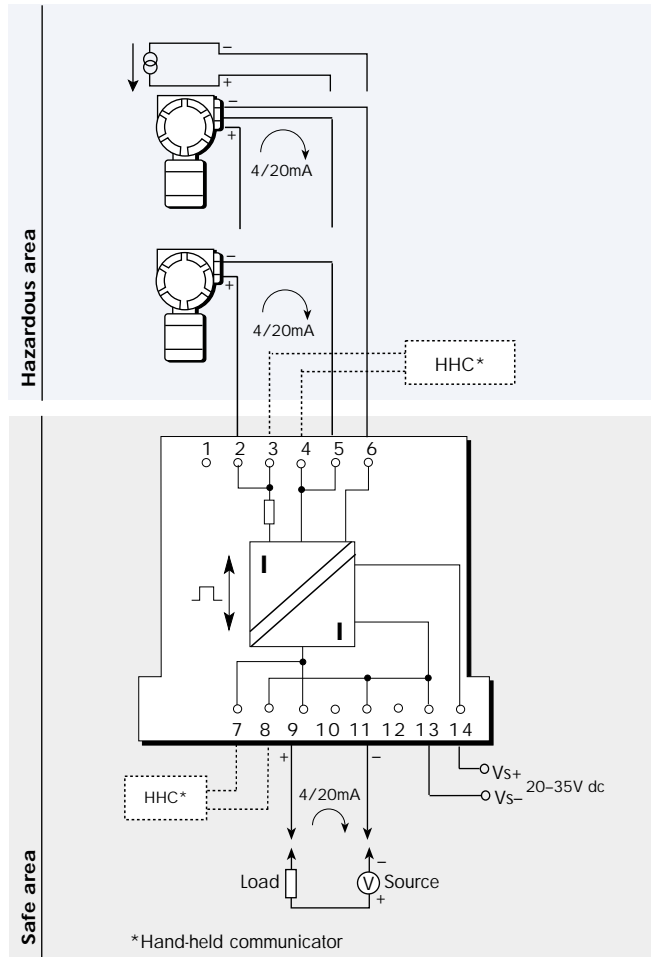

Terminal	Function
2	Tx supply +ve
3	Optional HHC connection +ve
4	Optional HHC connection -ve
5	Current input -ve
6	Common
7	Optional HHC connection +ve
8	Optional HHC connection -ve
9	Output +ve
11	Output -ve
13	Supply -ve
14	Supply +ve

Safety description

Terminals 2 to 5 and 6

28V, 300Ω, 93mA

Terminals 5 to 6

Non-energy storing apparatus ≤1.2V, ≤0.1A, ≤20μJ and ≤25mW; can be connected without further certification into any IS loop with open-circuit voltage not more than 28V

Note: terminals 5 to 6 only support HART communications in one direction from field device to safe-area connections 9 and 11.

FM entity parameters

Terminals 2, 5 and 6

$V_t = 28V$ dc, $I_t = 141mA$, $C_a = 0.13\mu F$, $L_a = 1.9mH$

Terminals 2, 4 and 5

$V_t = 28V$ dc, $I_t = 93mA$, $C_a = 0.13\mu F$, $L_a = 4.2mH$

HART® is a registered trademark of HART Communication Foundation



EUROPE (EMEA)
AMERICAS
ASIA PACIFIC
E-mail: enquiry@mtl-inst.com

Tel: +44 (0)1582 723633
Tel: +1 603 926 0090
Tel: +65 487 7887
Web site: www.mtl-inst.com

Fax: +44 (0)1582 422283
Fax: +1 603 926 1899
Fax: +65 487 7997

Sept 2002

MTL4044 REPEATER POWER SUPPLY

two channel, 4/20mA, smart,
for 2-wire transmitters



The MTL4044 provides fully floating dc supplies for energising two conventional 2-wire 4/20mA or 'smart' transmitters located in a hazardous area, and repeats the current in other circuits to drive two safe-area loads. For smart transmitters, the unit allows bi-directional transmission of digital communication signals superimposed on the 4/20mA signal so that the transmitter can be interrogated either from the operator station or by a hand-held communicator (HHC).

SPECIFICATION

See also common specification, cable parameters and approvals

Number of channels

Two

Location of transmitter

Zone 0, IIC, T4-6, hazardous area if suitably certified
Div 1, Group A, hazardous location

Voltage available for transmitter and lines

15V minimum at 20mA

Note: maximum open-circuit voltage is 28V

Input and output signal range

2.0mA to 22mA

Digital signal bandwidth

Hazardous-to-safe: dc to 10kHz

Safe-to-hazardous: 2Hz to 10kHz

Safe-area circuit load resistance

Conventional transmitters: 0 to 300Ω

Smart transmitters: 250Ω ±10%

Safe-area circuit output resistance

>1MΩ

Safe-area circuit ripple

<50μA peak-to-peak up to 80kHz

Transfer accuracy at 20°C

Better than 20μA

Temperature drift

<1μA/°C

Response time

Settles within 200μA of final value within 20ms

LED indicator

Green: one provided for power indication

Power requirement, Vs

(with both channels carrying 20mA signal)

90mA at 24V dc

105mA at 20V dc

65mA at 35V dc

Power dissipation within unit

(with both channels carrying 20mA signal)

1.2W at 24V dc

1.3W at 35V dc

Isolation

250V ac between safe- and hazardous-area circuits

Safety description

Terminals 2 to 3 and 5 to 6

28V, 300Ω, 93mA

FM entity parameters

$V_{oc} = 28V$ dc, $I_{sc} = 93mA$, $C_a = 0.13\mu F$, $L_a = 4.2mH$

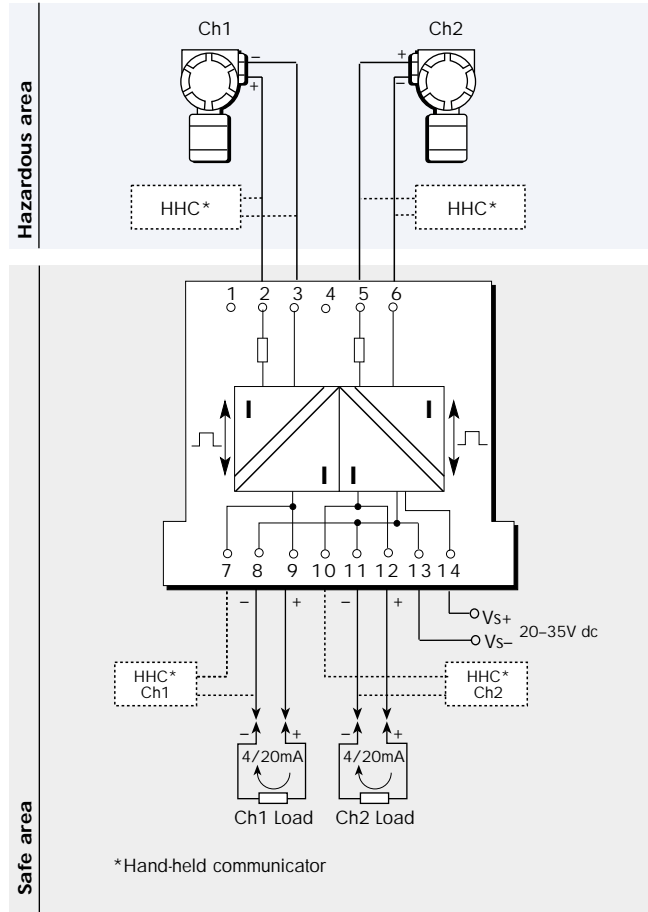

Terminal	Function
2	Ch1 tx supply +ve
3	Ch1 tx supply -ve
5	Ch2 tx supply +ve
6	Ch2 tx supply -ve
7	Ch1 optional HHC connection +ve
8	Ch1 output -ve/HHC -ve
9	Ch1 output +ve
10	Ch2 optional HHC connection +ve
11	Ch2 output -ve/HHC -ve
12	Ch2 output +ve
13	Supply -ve
14	Supply +ve



MTL4044D REPEATER POWER SUPPLY

one channel, two outputs
for 2-wire transmitters



The MTL4044D provide sa fully floating dc supply for energising a conventional 2-wire 4/20mA or 'smart' transmitter located in a hazardous area, and repeats the current in other circuits to drive two safe-area loads. Bi-directional transmission of 'smart' data and 4/20mA is available using output 1 whilst output 2 repeats only the 4/20mA.

SPECIFICATION

See also common specification, cable parameters and approvals

Number of channels

One

Location of transmitter

Zone 0, IIC, T4-6, hazardous area if suitably certified
Div 1, Group A, hazardous location

Voltage available for transmitter and lines

15V minimum at 20mA

Note: maximum open-circuit voltage is 28V

Input and output signal range

0.5mA to 22mA

Digital signal bandwidth

Hazardous-to-safe: dc to 10kHz

Safe-to-hazardous: 2Hz to 10kHz

Safe-area circuit load resistance

Conventional transmitters: 0 to 300Ω

Smart transmitters: 250Ω ±10%

Safe-area circuit output resistance

>1MΩ

Safe-area circuit ripple

<50μA peak-to-peak up to 80kHz

Transfer accuracy at 20°C

Better than 20μA

Temperature drift

<1μA/°C

Response time

Settles within 200μA of final value within 20ms

LED indicator

Green: one provided for power indication

Power requirement, Vs

95mA at 24V dc

Power dissipation within unit

1.2W at 24V dc

Isolation

250V ac between safe- and hazardous-area circuits

Safety description

Terminals 2 to 3

28V, 300Ω, 93mA

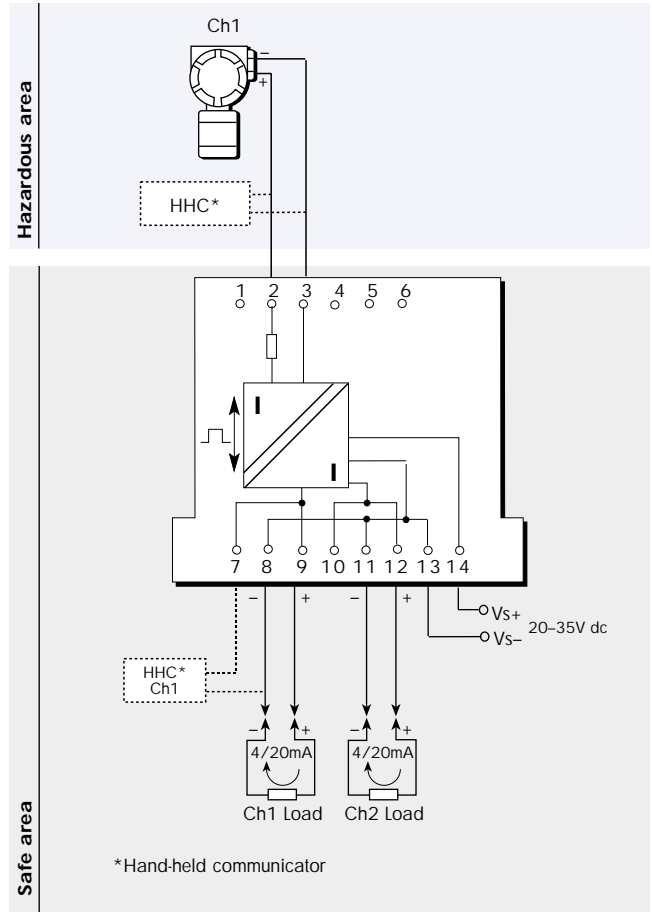

Terminal	Function
2	Ch1 tx supply +ve
3	Ch1 tx supply -ve
7	Ch1 optional HHC connection +ve
8	Ch1 output -ve/HHC connection -ve
9	Ch1 output +ve
10	Ch2 output +ve
11	Ch2 output -ve
12	Ch2 output +ve
13	Supply -ve (internally connected to terminals 8 and 11)
14	Supply +ve



EUROPE (EMEA)
AMERICAS
ASIA PACIFIC
E-mail: enquiry@mtl-inst.com

Tel: +44 (0)1582 723633
Tel: +1 603 926 0090
Tel: +65 487 7887

Fax: +44 (0)1582 422283
Fax: +1 603 926 1899
Fax: +65 487 7997

Web site: www.mtl-inst.com

MTL4045B/4045C

ISOLATING DRIVERS

4/20mA, with line fault detection



The MTL4045B accepts a 4/20mA signal from a safe-area controller and repeats it to drive a current/pressure (I/P) converter or any other load up to 800Ω in a hazardous area. The output capability is 16V at 20mA and the drop across the input terminals is low (4V). The input and output circuits float independently. Process controllers with a readback facility can detect an open or short circuit in the field wiring since, if this occurs, the resistance across the input terminals will change to a preset high value.

The MTL4045C is identical to the MTL4045B except that it provides open circuit detection only (no short circuit detection). The MTL4045B short circuit detection feature may not be compatible with some I/P positioners which have a high self-inductance. Consult your MTL representative for advice.

SPECIFICATION

See also common specification, cable parameters and approvals

Number of channels

One

Location of I/P converter

Zone 0, IIC, T4-6 hazardous area if suitably certified
Div.1, Group A, hazardous location

Working range

4 to 20mA

Maximum load resistance

800Ω (16V at 20mA)

Minimum load resistance (MTL4045B only)

90Ω (short circuit detection at <50Ω)

Output resistance

>1MΩ

Under/over range capability

1.0 to 21.4mA

Input and output circuit ripple

<40μA peak-to-peak

Input parameters

≤200Ω with the field wiring intact
>47kΩ with the field wiring open-circuit
<0.75mA with the field wiring short-circuit (MTL4045B only)

Transfer accuracy at 20°C

Better than 20μA

Temperature drift

<1.0μA/°C

Response time

Settles within 200μA of final value within 100ms

LED indicator

Green: one provided for power indication

Power requirement, Vs

50mA at 24V dc with 20mA signal
55mA at 20V dc
40mA at 35V dc

Power dissipation within unit

1.0W maximum at 24V with 20mA signal
1.2W at 35V

Isolation

250V ac between safe- and hazardous-area circuits.
Input circuit is floating; clamped to less than 10V above supply -ve permitting the use of a 250 current sense resistor in the return path.

Safety description

28V, 300Ω, 93mA; $U_m = 250V$ rms or dc

FM entity parameters

$V_{OC} = 28V$ dc, $I_{SC} = 93mA$, $C_a = 0.12\mu F$, $L_a = 4.2mH$

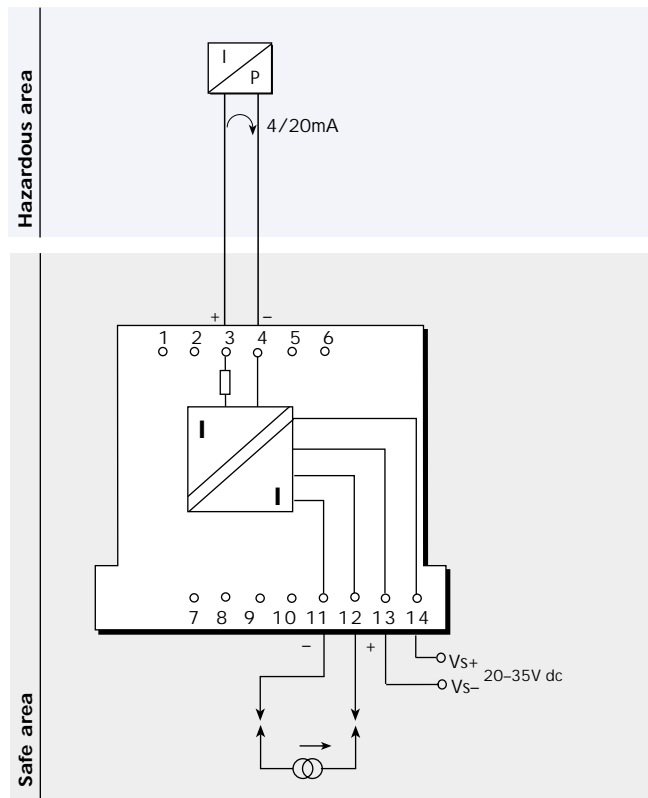

Terminal	Function
3	Output +ve
4	Output -ve
11	Input -ve
12	Input +ve
13	Supply -ve
14	Supply +ve



MTL4046/4046C ISOLATING DRIVER

for 4–20mA HART® valve positioners
with line fault detection



The MTL4046 accepts a 4/20mA floating signal from a safe-area controller to drive a current/pressure converter (or any other load up to 800Ω) in a hazardous area. For HART valve positioners, the module also permits bi-directional transmission of digital communication signals so that the device can be interrogated either from the operator station or by a hand-held communicator (HHC). Process controllers with a readback facility can detect open or short circuits in the field wiring: if these occur, the current taken into the terminals drops to a preset level. The MTL4046C is identical to the MTL4046 except that it provides open circuit detection only (no short-circuit detection).

SPECIFICATION

See also common specification, cable parameters and approvals

Number of channels

One

Location of I/P converter

Zone 0, IIC, T4–6 hazardous area if suitably certified
Div. 1, Group A, hazardous location

Working range

4 to 20mA

Digital signal bandwidth

500Hz to 10kHz

Maximum load resistance

800Ω (16V at 20mA)

Minimum load resistance

90Ω (short-circuit detection at <50Ω)

Output resistance

>1MΩ

Under/over range capability

Under range = 1.0mA
Over range = 26.0mA (load ≤520Ω)

Input and output circuit ripple

<40μA peak-to-peak

Transfer accuracy at 20°C

Better than 20μA

Input characteristics

<4.0V with the field wiring intact
<0.9mA with the field wiring open-circuit (and short-circuit on the MTL4046)

Response time

Settles within 200μA of final value within 100ms

Temperature drift

<1.0μA/°C

LED indicator

Green: one provided for power indication

Power requirement, Vs

58mA at 24V dc
70mA at 20V dc
40mA at 35V dc

Power dissipation within unit

1.2W typical at 24V with 20mA loop current
1.4W worst case

Isolation

250V ac between safe- and hazardous-area circuits
Input circuit is floating

Safety description

28V, 300Ω, 93mA, $U_m = 250V$ rms or dc

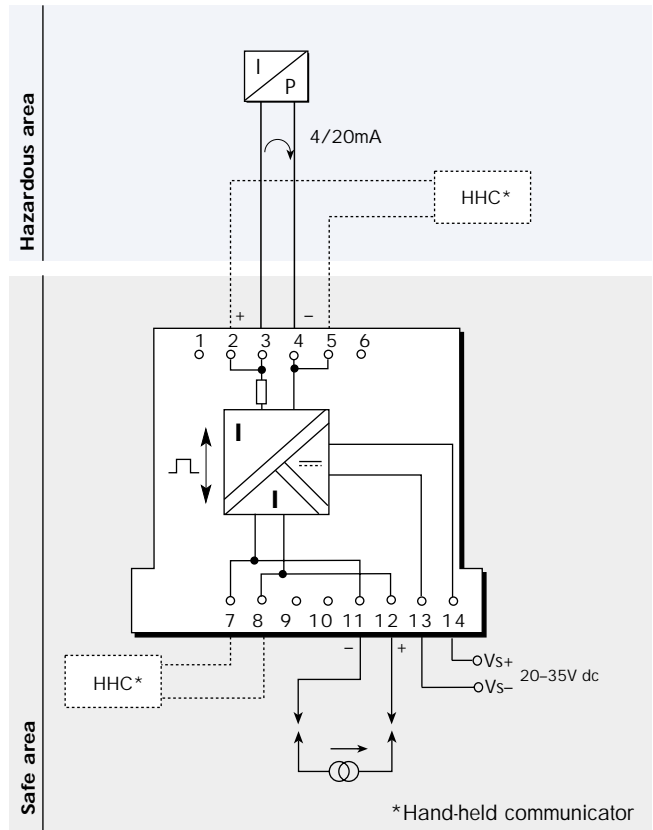

Terminal	Function
2	Optional HHC connection +ve
3	Output +ve
4	Output -ve
5	Optional HHC connection -ve
7	Optional HHC connection -ve
8	Optional HHC connection +ve
11	Input -ve
12	Input +ve
13	Supply -ve
14	Supply +ve

HART® is a registered trademark of HART Communication Foundation



EUROPE (EMEA) Tel: +44 (0)1582 723633 Fax: +44 (0)1582 422283
AMERICAS Tel: +1 603 926 0090 Fax: +1 603 926 1899
ASIA PACIFIC Tel: +65 487 7887 Fax: +65 487 7997
E-mail: enquiry@mtl-inst.com Web site: www.mtl-inst.com

Sept 2002

MTL4046P HIGH POWER ISOLATING DRIVER

4–20mA with line fault detection for HART® valve positioners



The MTL4046P accepts a 4/20mA floating signal from a safe-area controller to drive a current/pressure converter (or any other floating load up to 870Ω) in a hazardous area. For HART valve positioners, the module also permits bi-directional transmission of digital communication signals so that the device can be interrogated either from the operator station or by a hand-held communicator (HHC). Process controllers with a readback facility can detect open or short circuits in the field wiring: if these occur, the current taken into the terminals drops to a preset level.

SPECIFICATION

See also common specification, cable parameters and approvals

Number of channels

One

Location of I/P converter

Zone 0, IIC, T4–6 hazardous area if suitably certified
Div. 1, Group A, hazardous location

Working range

4 to 20mA

Digital signal bandwidth

500Hz to 10kHz

Maximum load resistance

870Ω (17.4V at 20mA)

Minimum load resistance

90Ω (short circuit detection at <50Ω)

Output resistance

>1MΩ

Under/over range capability

Under range = 1.0mA
Over range = 26.0mA (load ≤600Ω)

Input and output circuit ripple

<40μA peak-to-peak

Transfer accuracy at 20°C

Better than 20μA

Input characteristics

<4.0V with the field wiring intact
<0.9mA with the field wiring open- or short-circuit

Response time

Settles within 200μA of final value within 100ms

Temperature drift

<1.0μA/°C

LED indicator

Green: one provided for power indication

Power requirement, Vs

58mA at 24V dc
70mA at 20V dc
40mA at 35V dc

Power dissipation within unit

1.2W typical at 24V with 20mA loop current
1.4W worst case

Isolation

250V ac between safe- and hazardous-area circuits
Input circuit is floating

Safety description

28V, 240Ω, 116mA, $U_m = 250V$ rms or dc

FM entity parameters

$V_t = 28V$ dc, $I_{sc} = 117mA$, $C_a = 0.14\mu F$, $L_a = 2.6mH$

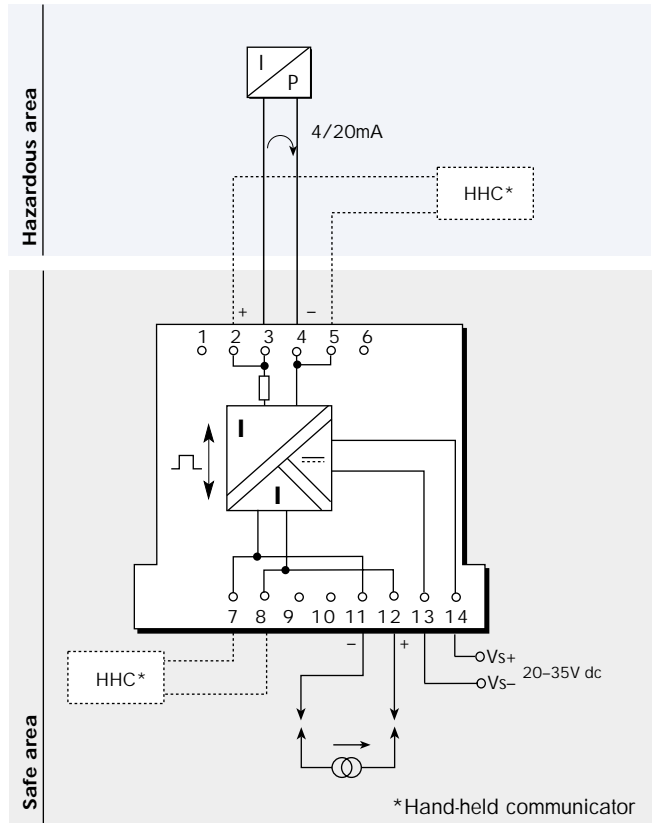

*Hand-held communicator

Terminal	Function
2	Optional HHC connection +ve
3	Output +ve
4	Output -ve
5	Optional HHC connection -ve
7	Optional HHC connection -ve
8	Optional HHC connection +ve
11	Input -ve
12	Input +ve
13	Supply -ve
14	Supply +ve

HART® is a registered trademark of HART Communication Foundation



EUROPE (EMEA) Tel: +44 (0)1582 723633 Fax: +44 (0)1582 422283
AMERICAS Tel: +1 603 926 0090 Fax: +1 603 926 1899
ASIA PACIFIC Tel: +65 487 7887 Fax: +65 487 7997
E-mail: enquiry@mtl-inst.com Web site: www.mtl-inst.com

Sept 2002

MTL4046S ISOLATING DRIVER

for HART[®] valve positioners
with open-circuit detection



The MTL4046S accepts a 4/20mA floating signal from a safe-area controller to drive a current/pressure converter (or any other load up to 710Ω) in a hazardous area. For HART valve positioners, the module also permits bi-directional transmission of digital communication signals so that the device can be interrogated either from the operator station or by a hand-held communicator (HHC). Process controllers with a readback facility can detect open circuits in the field wiring: if these occur, the current taken into the terminals drops to a preset level. The reduced maximum open-circuit voltage permits the use of longer field lines compared to MTL4046C.

SPECIFICATION

See also common specification, cable parameters and approvals

Number of channels

One

Location of I/P converter

Zone 0, IIC, T4–6 hazardous area if suitably certified
Div. 1, Group A, hazardous location

Working range

4 to 20mA

Digital signal bandwidth

500Hz to 10kHz

Maximum load resistance

710Ω (17.4V at 20mA)

Output resistance

>1MΩ

Under/over range capability

Under range = 1.0mA
Over range = 26.0mA (load ≤460Ω)

Input and output circuit ripple

<40μA peak-to-peak

Transfer accuracy at 20°C

Better than 20μA

Input characteristics

<4.0V with the field wiring intact
<0.9mA with the field wiring open- or short-circuit

Response time

Settles within 200μA of final value within 100ms

Temperature drift

<1.0μA/°C

LED indicator

Green: one provided for power indication

Power requirement, V_s

58mA at 24V dc
70mA at 20V dc
40mA at 35V dc

Power dissipation within unit

1.2W typical at 24V with 20mA loop current
1.4W worst case

Isolation

250V ac between safe- and hazardous-area circuits
Input circuit is floating

Safety description

22V, 220Ω, 100mA, U_m = 250V rms or dc

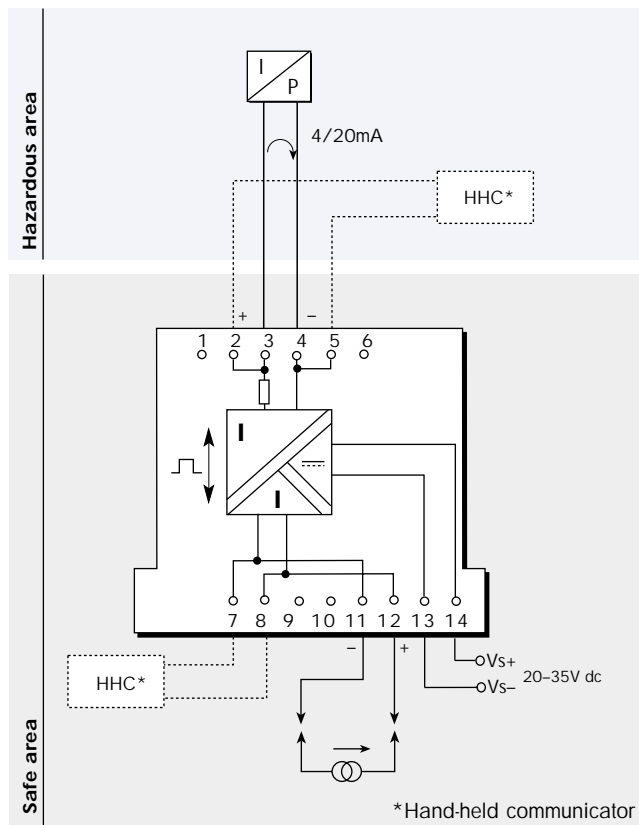

*Hand-held communicator

Terminal	Function
2	Optional HHC connection +ve
3	Output +ve
4	Output -ve
5	Optional HHC connection -ve
7	Optional HHC connection -ve
8	Optional HHC connection +ve
11	Input -ve
12	Input +ve
13	Supply -ve
14	Supply +ve

HART[®] is a registered trademark of HART Communication Foundation



EUROPE (EMEA) Tel: +44 (0)1582 723633 Fax: +44 (0)1582 422283
AMERICAS Tel: +1 603 926 0090 Fax: +1 603 926 1899
ASIA PACIFIC Tel: +65 487 7887 Fax: +65 487 7997
E-mail: enquiry@mtl-inst.com Web site: www.mtl-inst.com

Sept 2002

MTL4048 LOOP-POWERED ISOLATOR

4/20mA, for Foxboro 'intelligent' transmitters



The MTL4048 is designed primarily for use with Foxboro 'intelligent' transmitters operating in the digital mode. It acts like a direct-current transformer. Being powered from the safe-area side, the same current flows in both hazardous and safe-area circuits and can be controlled from either. It provides bi-directional transmission of digital communication signals so that the transmitter can be interrogated either from the operator station or by a hand-held communicator (HHC).

SPECIFICATION

See also common specification, cable parameters and approvals

Number of channels

One, fully floating

Location of transmitter

Zone 0, IIC, T4-6 hazardous area if suitably certified
Div.1, Group A, hazardous location

Input and output signal range

4 to 20mA

Input voltage, V_s

9 to 35V dc

Minimum output voltage

Input voltage V_{in}	Minimum output voltage V_{out}
<24V	$V_{in} - (0.4 \times \text{current in mA}) - 1V$
>24V	$23V - (0.4 \times \text{current in mA})$

Input and output ripple

<100µA peak-to-peak

Transfer accuracy at 20°C

Better than 400µA

Temperature drift

<5µA/°C (0 to 60°C)

<8.5µA/°C (-20 to 0°C)

Response time

Settles within 10% of final value within 100ms

Digital signal bandwidth

3kHz to 15kHz

Power dissipation within unit

0.4W typical at 24V with 20mA signal

0.6W typical at 35V

Safety description

28V, 300Ω, 93mA, $U_m = 250V$ rms or dc

FM entity parameters

Not yet available

Isolation

250V ac between safe- and hazardous-area circuits

Hazardous area

Safe area

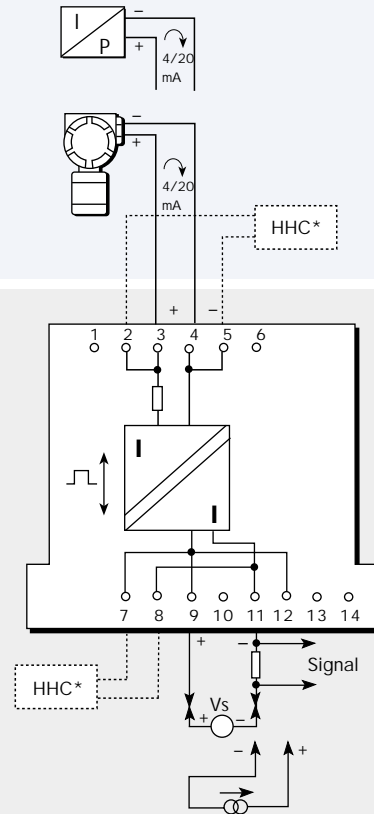

*Hand-held communicator

Terminal	Function
2	Optional HHC connection +ve
3	Tx or I/P connection +ve
4	Tx or I/P connection -ve
5	Optional HHC connection -ve
7	Optional HHC connection +ve
8	Optional HHC connection -ve
9	Load connection +ve
11	Controller or load connection -ve
12	Controller connection +ve



MTL4061 FIRE AND SMOKE DETECTOR INTERFACE

two-channel



The MTL4061 is a loop-powered 2-channel interface for use with conventional fire and smoke detectors located in hazardous areas. In operation, the triggering of a detector causes a corresponding change in the safe-area current. The unit features reverse input polarity protection, while 'no-fail' earth fault detection on either line can be provided by connecting an MTL4220 earth leakage detector to terminal 1 or 4.

SPECIFICATION

See also common specification, cable parameters and approvals

Number of channels

Two, fully floating, loop powered

Location of fire and smoke detectors

Zone 0, IIC, T4-6 hazardous area if suitably certified
Div. 1, Group A, hazardous area

Input voltage

6 to 35V dc

Current range

1 to 40mA, nominal

Quiescent safe-area current at 20°C

(hazardous-area terminals open circuit)
<400µA at $V_{in} = 24V$ per channel

Integral input polarity protection

Input circuit protected against reverse polarity

'No-fail' earth fault protection

Enabled by connecting terminals 1 and 4 to an MTL4220 earth leakage detector
Fault on either line of each channel proclaimed: unit continues working

Note: 1. To maintain isolation between the two channels, separate earth leakage detectors are needed
2. The earth leakage detectors introduce a 100µA, 1Hz ripple to the field circuit

Minimum output voltage V_{out} at 20°C

$V_{in} - (0.38 \times \text{current in mA}) - 2V$
21V - (0.35 x current in mA)
whichever is lower

Maximum output voltage

28V from 300Ω

Transfer accuracy at 20°C

Better than 400µA

Temperature drift

<10µA/°C (-20 to 60°C)

Response time to step input

Settles to within 500µA of final value within 30ms

Power dissipation within unit

0.7W maximum at 24V with 40mA signal (each channel)
1.2W maximum at 35V with 40mA signal (each channel)

Isolation

250Vac between safe- and hazardous-area circuits

Safety description for each channel

28V, 300Ω, 93mA.

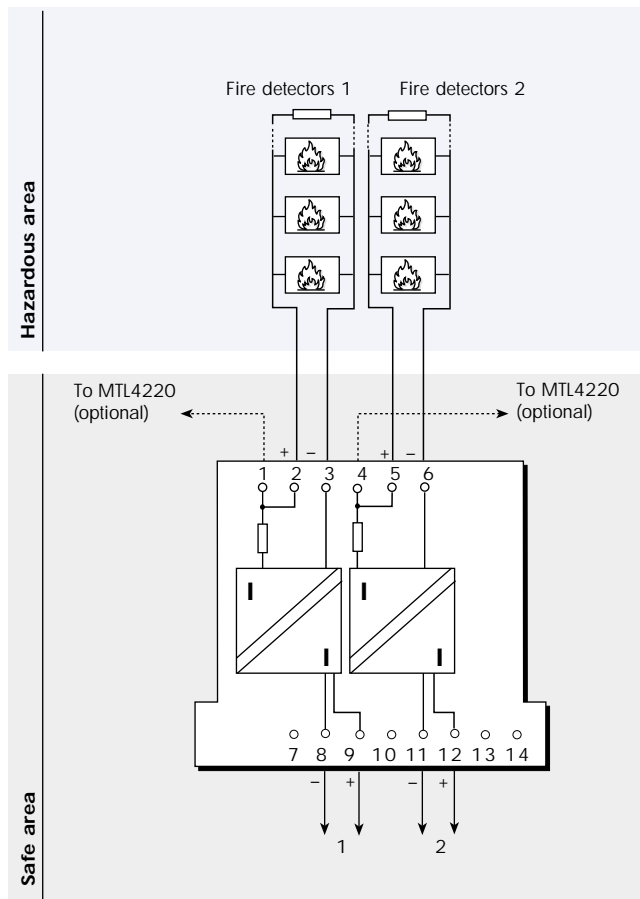

Terminal	Function
1	Optional link from input 1 to MTL4220
2	Output 1 +ve
3	Output 1 -ve
4	Optional link from input 2 to MTL4220
5	Output 2 +ve
6	Output 2 -ve
8	Input 1 -ve
9	Input 1 +ve
11	Input 2 -ve
12	Input 2 +ve



MTL4073 TEMPERATURE CONVERTER

THC or RTD input



The MTL4073 converts a low level dc signal from a temperature sensor mounted in a hazardous area into a 4/20mA current for driving a safe-area load. Software selectable features include linearisation, ranging, monitoring, testing and tagging for eight thermocouple types and 2-, 3-, and 4-wire RTDs. For THC inputs requiring cold-junction compensation, an SCJ01 hazardous-area connector (which is provided with an integral CJC sensor) should be used. Configuration is carried out using a personal computer.

SPECIFICATION

See also common specification, cable parameters and approvals and details of SCJ01 hazardous-area connector, with integral CJC sensor, for thermocouple inputs requiring cold junction compensation, in 'MTL4000 Series Accessories'

Number of channels

One

Signal source

Types J, K, T, E, R, S, B or N THCs to BS 4937

EMF input

2/3/4-wire platinum RTDs to BS 1904/DIN 43760 (100Ω at 0°C)

Location of signal source

Zone 0, IIC, T4 hazardous area

Div.1, Group A, hazardous location

Input signal range

-75 to +75mV, or 0 to 400Ω

Input signal span

3 to 150mV, or 10 to 400Ω

RTD excitation current

200μA nominal

Cold junction compensation

Automatic or selectable

Cold junction compensation error

≤1.0°C

Common mode rejection

120dB for 240V at 50Hz or 60Hz

Series mode rejection

40dB for 50Hz or 60Hz

Calibration accuracy (at 20°C)

(includes hysteresis, non-linearity and repeatability)

Inputs:

mV/THC: ±15μV or ±0.05% of input value (whichever is greater)

RTD: ±80mΩ

Output: ±11μA

Temperature drift (typical)

Inputs:

mV/THC: ±0.003% of input value/°C

RTD: ±7mΩ/°C

Output: ±0.6μA/°C

Example of calibration accuracy and temperature drift (RTD input)

Span: 250Ω

Accuracy: ±(0.08/250 + 11/16000) x 100% = 0.1% of span

Temperature drift: ±(0.007/250 x 16000 + 0.6) μA/°C = ±1.0μA/°C

Safety drive on sensor burnout

Upscale, downscale, or off

Output range

4 to 20mA nominal (direct or reverse)

Maximum load resistance

600Ω

LED indicator

Green: one provided for power and status indication

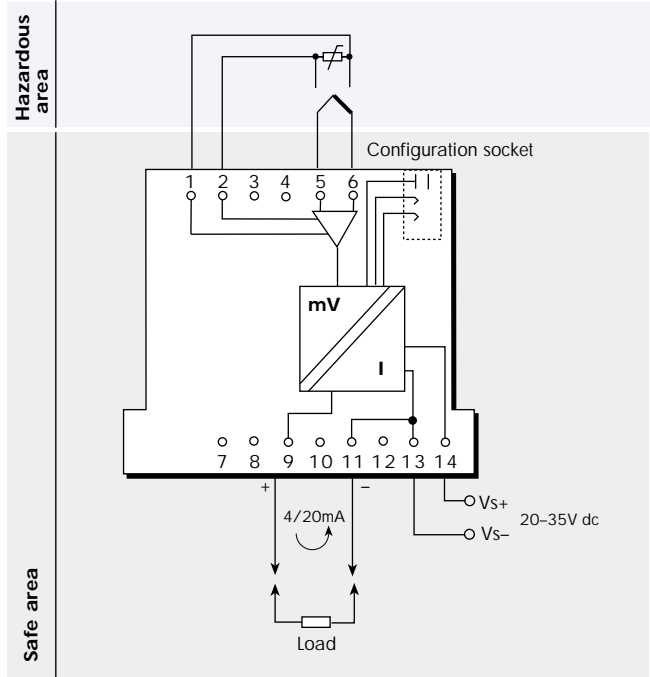

Terminal	Function
1	3-wire RTD input -ve
2	4-wire RTD input +ve
5	THC/EMF/RTD input +ve
6	THC/EMF/RTD input -ve
9	Output +ve
11	Output -ve
13	Supply -ve
14	Supply +ve

Power requirement, Vs

57mA at 24V

55mA at 20V

60mA at 35V with 20mA signal

Power dissipation within unit

1.2W at 24V with 20mA signal

2.0W at 35V

Isolation

250V ac between safe- and hazardous-area circuits

Safety description

Terminals 5 and 6

Non-energy-storing apparatus ≤1.2V, ≤0.1A, ≤20μJ, and ≤25mW. Can be connected without further certification into any IS loop with open-circuit voltage not more than 10V.

Terminals 1 and 2

7.2V, 950Ω, 8mA

Configuration socket

U_{max}: in = 11.2V, I_{max}: in = 12mA, W_{max}: in = 280mW

U_{max}: out = 7.2V, I_{max}: out = 8mA, W_{max}: out = 15mW

FM entity parameters

Terminals 1, 2, 5 and 6

V_t ≤ 7.2V, I_t ≤ 11.5mA, C_a ≤ 11.0μF, L_a ≤ 245mH

Terminals 5 and 6 only

V_t ≤ 1.2V, I_t ≤ 3.8mA, C_a ≤ 1000μF, L_a ≤ 3.6mH

Standard configuration

Input type	Type K thermocouple
Linearisation/CJ Compensation	enabled/enabled
Units	°C
Damping/Smoothing value	0 seconds/0 seconds
Output zero	0°C
Output span	250°C
Tag and description fields	blank
Open circuit alarm	set high (upscale)
Transmitter failure alarm	set low (downscale)
CJ failure alarm	set low (downscale)
Line frequency	50Hz

Configurator

A personal computer running MTL PCS45 software with a PCL45 interface.



MTL4081 MILLIVOLT/ THERMOCOUPLE ISOLATOR

for low-level signals



The MTL4081 takes a low-level dc signal from a voltage source in a hazardous area, isolates it, and passes it to a receiving instrument located in the safe area. The module is intended for use with strain-gauge bridges or thermocouples utilising external cold-junction compensation. A switch located on top of the module enables or disables the safety drive in the event of thermocouple burnout or cable breakage; a second switch permits the selection of upscale or downscale operation as appropriate.

SPECIFICATION

See also common specification, cable parameters and approvals

Number of channels

One

Signal source

Any dc millivolt source

Location of millivolt source

Zone 0, IIC, T4–T6 hazardous area if suitably certified
Div. 1, Group A, hazardous location

Input and output signal range

0 to $\pm 50\text{mV}$, overrange to $\pm 55\text{mV}$

Output resistance

60Ω nominal

Transfer accuracy

Linearity and repeatability $<0.05\%$ of reading or $\pm 5\mu\text{V}$, whichever is the greater

Temperature drift

$<2\mu\text{V}/^\circ\text{C}$, maximum

Response time

Settles to within 10% of final value within 150 μs

Frequency response

DC to 4kHz nominal

Safety drive on THC burnout

Two switches on top of the module enable or disable the safety drive and select upscale or downscale operation

LED indicator

Green: one provided for power indication

Power requirement, V_s

26mA max, 20V dc to 35V dc

Power dissipation within unit

0.6W typical at 24V

0.9W at 35V

Isolation

250V ac between safe- and hazardous-area circuits

Safety description

Terminals 5 and 6

$U_{\text{max out}}$ 1.0V

$I_{\text{max out}}$ 47.8mA

$P_{\text{max out}}$ 0.012W

Non-energy-storing apparatus $\leq 1.2\text{V}$, $\leq 0.1\text{A}$, $\leq 20\mu\text{J}$ and $\leq 25\text{mW}$.

Can be connected without further certification into any IS loop with open-circuit voltage not more than 28V.

* Note: output negative (terminal 11) is clamped to supply negative (terminal 13) through two series diodes

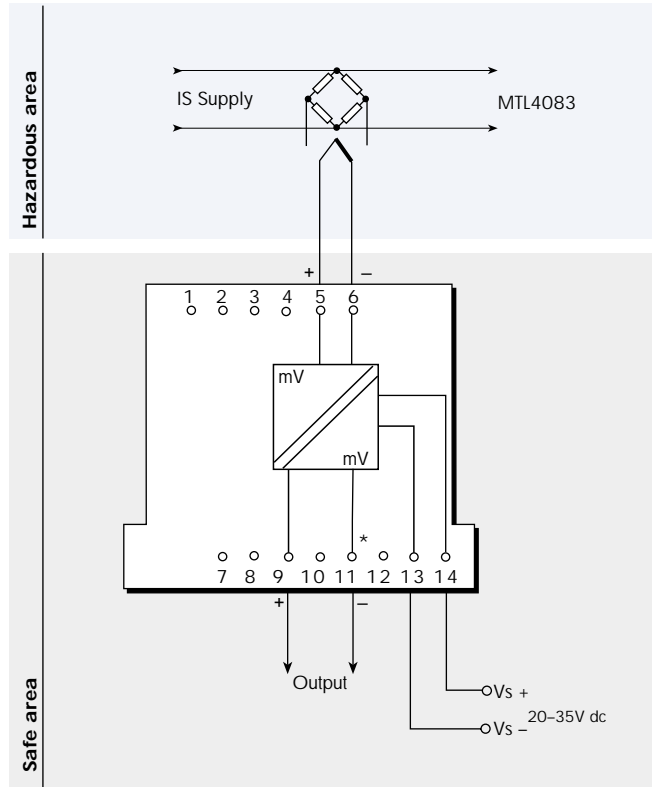

Terminal	Function
5	THC/EMF input +ve
6	THC/EMF input -ve
9	Output +ve
11	Output -ve
13	Supply -ve
14	Supply +ve



MTL4083 VOLTAGE ISOLATOR



The MTL4083 takes a dc signal from a voltage source in a hazardous area, isolates it, and passes it to a receiving instrument located in the safe area. It is intended for use with strain-gauge bridges, slide-wire transducers and various voltage sources.

SPECIFICATION

See also common specification, cable parameters and approvals

Number of channels

One

Location of source

Zone 0, IIC, T4 hazardous area if suitably certified
Div. 1, Group A, hazardous location

Input and output signal range

0 to 12V, over range to +12.5V

Signal input resistance

>10M Ω

Output resistance

<50 Ω (recommended load resistance \geq 10k Ω)

Transfer accuracy

Linearity and repeatability <0.05% of reading (input \geq 1V)

Temperature drift

<600 μ V/ $^{\circ}$ C

Response time

Settles to within 10% of final value typically within 200 μ s

Frequency response

DC to 4kHz nominal

LED indicator

Green: one provided for power indication

Power requirement, Vs

31mA max, 20 to 35V dc

Power dissipation within unit

0.7W typical at 24V

1.1W at 35V

Isolation

250V ac between safe- and hazardous-area circuits

Safety description

16V, 950 Ω , 17mA

*Note: output negative (terminal 11) is clamped to supply negative (terminal 13) through two series diodes

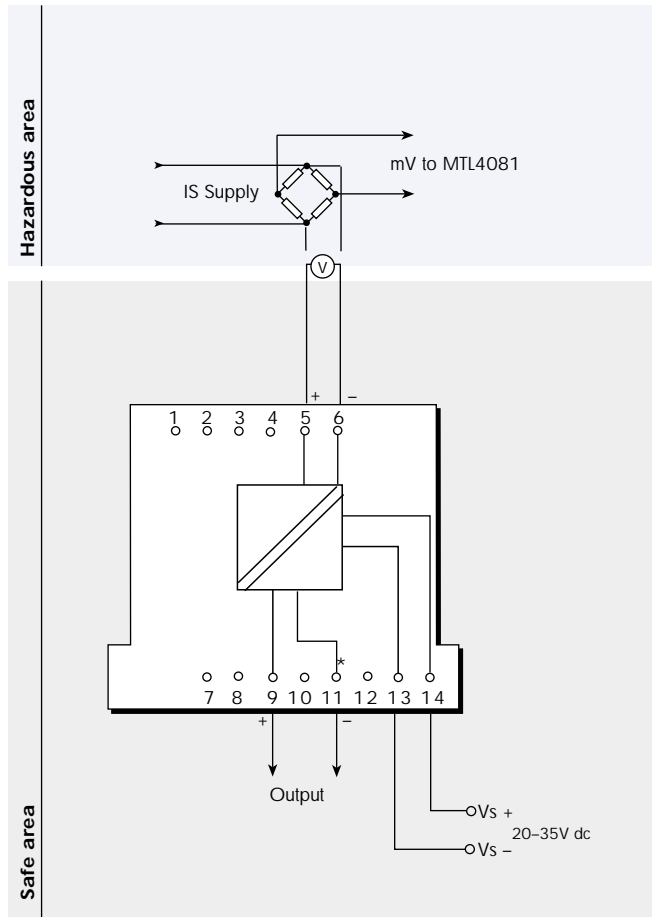

Terminal	Function
5	Voltage input +ve
6	Voltage input -ve
9	Voltage output +ve
11	Voltage output -ve
13	Supply -ve
14	Supply +ve



MTL4113P AND 4114P FAILSAFE SWITCH/PROXIMITY DETECTOR INTERFACE

LFD option



With the MTL4113P/4114P, a fail-safe switch/proximity detector located in the hazardous area can control an isolated fail-safe electronic output. The MTL4113P units provide line fault detection alarm contacts. The MTL4113P and MTL4114P are for use with P + F TÜV approved fail-safe sensors.

SPECIFICATION

(For both MTL4113P and MTL4114P unless otherwise indicated)
See also common specification, cable parameters and approvals

Number of channels

One

Location of switches

Zone 0, IIC, T6 hazardous area
Div. 1, Group A hazardous location

Location of proximity detector

Zone 0, IIC, T4-6, hazardous location
Div 1, Group A, hazardous location

Voltage applied to sensor

9.7V dc max from 1k Ω

Input/output characteristics

Input value in sensor circuit	Fail-safe output	Operation	LFD contacts (MTL4113P only)
MTL4113P, MTL4114P 2.9mA < I_s < 3.9mA	ON	Normal	CLOSED
MTL4113P, MTL4114P I_s < 1.9mA & I_s > 5.1mA	OFF	Normal	CLOSED
MTL4113P I_s < 50 μ A	OFF	Broken line	OPEN
MTL4113P I_s > 6.6mA	OFF	Shorted line	OPEN

Note: I_s = sensor current

Fail-safe electronic output

Output on: 24V nominal
Output off: 0V dc, max <5V dc
Load: 2.4k Ω to 10k Ω
Maximum on-state current: 11mA
Short-circuit current: 25mA

Line fault detection (LFD), MTL4113P only

Relay output for line fault (contacts open when line fault detected)
Switch characteristics: 35V ac/dc, 1A

LED indicators

Amber: one provided for output status, ON when fail-safe output is energised
Green: one provided for power indication
Red: one provided for LFD, ON when line fault is detected (MTL4113P only)

Power requirements, V_s

MTL4113P	MTL4114P	
80mA	70mA	at 20V dc
70mA	60mA	at 24V dc
65mA	45mA	at 35V dc

Power dissipation within unit

MTL4113P	MTL4114P	
1.4W	1.2W	at 20V dc
1.5W	1.3W	at 24V dc
2.0W	1.4W	at 35V dc

Isolation

253V ac between safe- and hazardous-area circuits

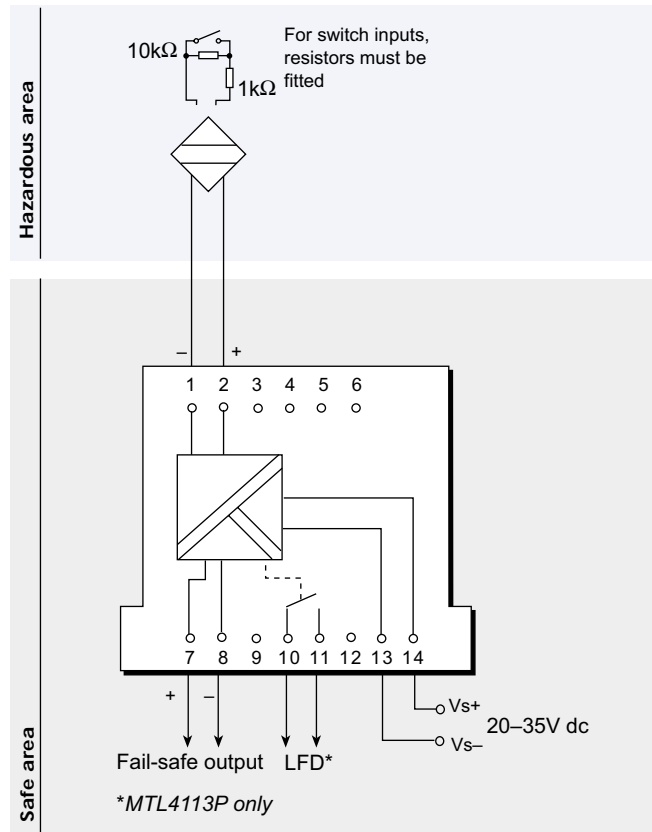

Terminal	Function
1	Input -ve
2	Input +ve
7	Output +ve
8	Output -ve
10	LFD (MTL4113P only)
11	LFD (MTL4113P only)
13	Supply -ve
14	Supply +ve

Safety description

$U_o = 9.7V$, $I_o = 30mA$, $P_o = 0.07W$, $U_m = 253V$

Note: switch-type sensors must be fitted with resistors as shown



MTL4215 SWITCH OPERATED RELAY

IS-output



The MTL4215 enables either one or two separate IS circuits in a hazardous area to be relay-contact controlled by a single on/off switch or logic signal in a safe area. Applications include the calibration of strain-gauge bridges, changing the polarity (and thereby the tone) of an IS sounder, the testing of IS fire alarms, and the transfer of safe-area signals into an annunciator with IS input terminals not segregated from each other. The output-relay contacts are certified as non-energy storing apparatus, and can be connected to any IS circuit without further certification, provided that separate IS circuits are such that they would still remain safe if connected together.

SPECIFICATION

See also common specification, cable parameters and approvals

Number of channels

One, fully floating

Location of control circuit

Safe area

Input/output characteristics

Input suitable for switch contacts, an open-collector transistor or logic drive.

Relay energised if $<27k\Omega$ or $<1V$ applied

Relay de-energised if $>54k\Omega$ or $>2V$ applied (50V maximum)

Hysteresis, nominal $15k\Omega$ or 0.5V

Power supply failure protection

Relay de-energised if supply fails

Response time

25ms nominal

Contacts (suitable for connection to IS circuits)

2-pole changeover

Contact rating

100V dc, limited to 30V dc for IS applications, 250mA

5VA (reactive loads must be suppressed)

$<150m\Omega$ contact resistance

Contact life expectancy

2×10^5 operations at maximum load

LED indicators

Amber: one provided for relay status, ON when relay energised

Green: one provided for power indication

Power requirement, V_s

25mA at 24V dc

20mA at 20V dc

40mA at 35V dc

Power dissipation within unit

0.6W maximum at 24V dc

1.4W maximum at 35V dc

Isolation

250V ac between safe- and hazardous-area circuits

Safety description (each channel)

Non-energy storing apparatus: relay contacts may be connected to any IS circuit without further consideration

FM entity parameters

$V_{oc} = 0V$, $I_{sc} = 0mA$, $C_a = 10,000\mu F$, $L_a = 1.0mH$

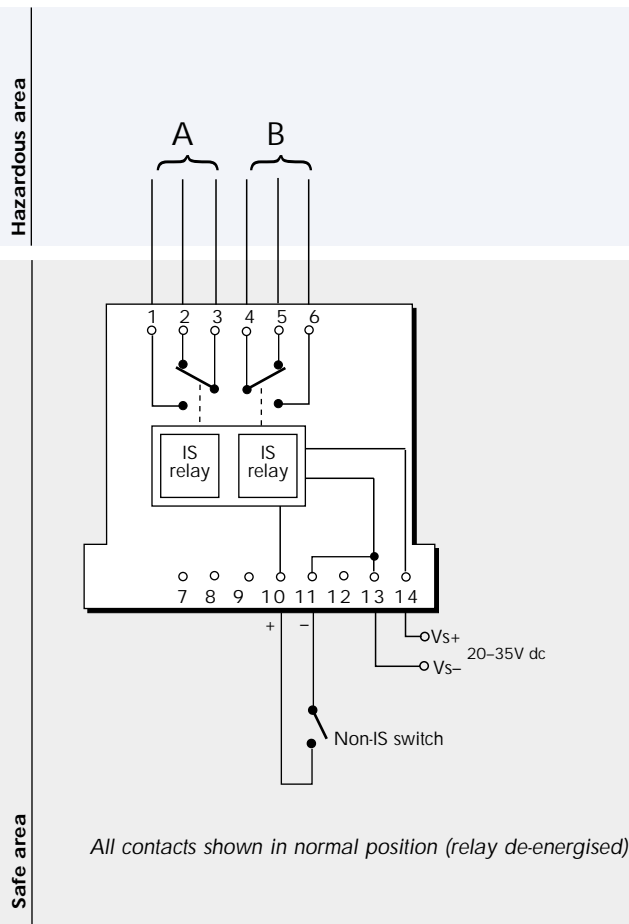

Terminal	Function
1	IS relay output A (normally open)
2	IS relay output A (normally closed)
3	IS relay output A (common)
4	IS relay output B (common)
5	IS relay output B (normally closed)
6	IS relay output B (normally open)
10	Relay control +ve
11	Relay control -ve
13	Supply -ve
14	Supply +ve



MTL4216 SWITCH OPERATED RELAY

two-channel IS-output



The MTL4216 enables two separate IS circuits in a hazardous area to be relay-contact controlled by two on-off switches or logic signals in a safe area. Applications include the calibration of strain-gauge bridges; changing the polarity (and thereby the tone) of an IS sounder; the testing of IS fire alarms; and the transfer of safe-area signals into an annunciator with IS input terminals not segregated from each other. The output-relay contacts are certified as non-energy-storing apparatus, and can be connected to any IS circuit without further certification, provided that separate IS circuits are such that they would remain safe if connected together.

SPECIFICATION

See also common specification, cable parameters and approvals

Number of channels

Two, fully floating

Location of control circuit

Safe area

Input/output characteristics

Inputs suitable for switch contacts, an open-collector transistor or logic drive

Relay energised if $<27k\Omega$ or $<1V$ applied

Relay de-energised if $>54k\Omega$ or $>2V$ applied (50V maximum)

Hysteresis, nominal $15k\Omega$ or $0.5V$

Power supply failure protection

Relays de-energised if supply fails

Response time

25ms nominal

Contacts (suitable for connection to IS circuits)

1-pole changeover per channel

Contact rating

100V dc, limited to 30V dc for IS applications, 250mA

5VA (reactive loads must be suppressed)

$<150m\Omega$ contact resistance

Contact life expectancy

2×10^5 operations at maximum load

LED indicators

Amber: one provided for each channel, ON when relay is energised

Green: one provided for power indication

Power requirement, V_s

25mA at 24V dc

20mA at 20V dc

40mA at 35V dc

Power dissipation within unit

0.6W maximum at 24V

1.4W worst case

Isolation

250V ac between safe- and hazardous-area circuits

Safety description (each channel)

Non-energy-storing apparatus: relay contacts may be connected to any IS circuit without further consideration

FM entity parameters

$V_{oc} = 0V$, $I_{sc} = 0mA$, $C_a = 10,000\mu F$, $L_a = 1.0H$

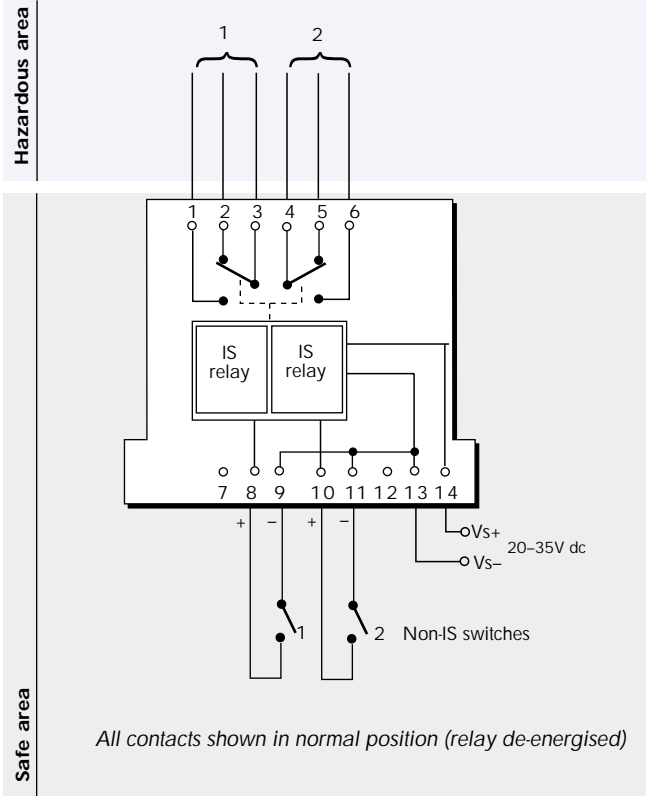

Terminal	Function
1	IS relay output 1 (normally open)
2	IS relay output 1 (normally closed)
3	IS relay output 1 (common)
4	IS relay output 2 (common)
5	IS relay output 2 (normally closed)
6	IS relay output 2 (normally open)
8	Relay 1 control +ve
9	Relay 1 control -ve
10	Relay 2 control +ve
11	Relay 2 control -ve
13	Supply -ve
14	Supply +ve



MTL4220 EARTH LEAKAGE DETECTOR



The MTL4220 scans up to eight floating electrical circuits, hazardous or safe area, and warns if the resistance to earth on any input falls below 10kΩ. It enables other MTL4000 Series units to be used in the 'no-fail' mode, whereby earth faults on field lines can be detected and rectified without upsetting control or needing emergency action. Eight LED indicators enable faults to be easily located to any input. A self-test facility enables the unit to be checked automatically or manually to ensure the integrity of the whole system. During test the relay is de-energised and the eight LED indicators are illuminated if the unit is healthy. This has no effect on the monitored circuits.

SPECIFICATION

See also common specification, cable parameters and approvals

Number of inputs

Eight independent inputs

Signal source

MTL4000 Series modules with provision for earth leakage detection

Note: inputs are not isolated from each other

Monitoring signal

5V, 0.1mA, 1Hz, intrinsically safe

Earth fault resistance to de-energise relay (7-8 closed)

<10kΩ, on any input

Earth fault resistance that will not de-energise relay (8-9 closed)

>50kΩ, on all inputs

Response time

<50s for 8 input scan

Series mode rejection

60V dc, 10V rms 50Hz

Relay output characteristics

Single pole changeover

Contact rating: 35V dc, 250mA, 5VA

Contact life expectancy: 10⁵ operations at maximum load

Note: reactive loads must be adequately suppressed

LED indicators

Red: one provided for each of eight inputs, ON when earth fault detected on the corresponding input

Green: one provided for power indication

Test facility

Terminals 10 and 11 are suitable for switch contacts, an open-collector transistor or logic drive:

TEST = input switch closed, transistor on or <1.4V applied across terminals 10 and 11; relay will de-energise within 1s and all red LED indicators light

OPERATE = input switch open, transistor off or >4.5V applied across terminals 10 and 11; relay will return to normal operating mode within 50s

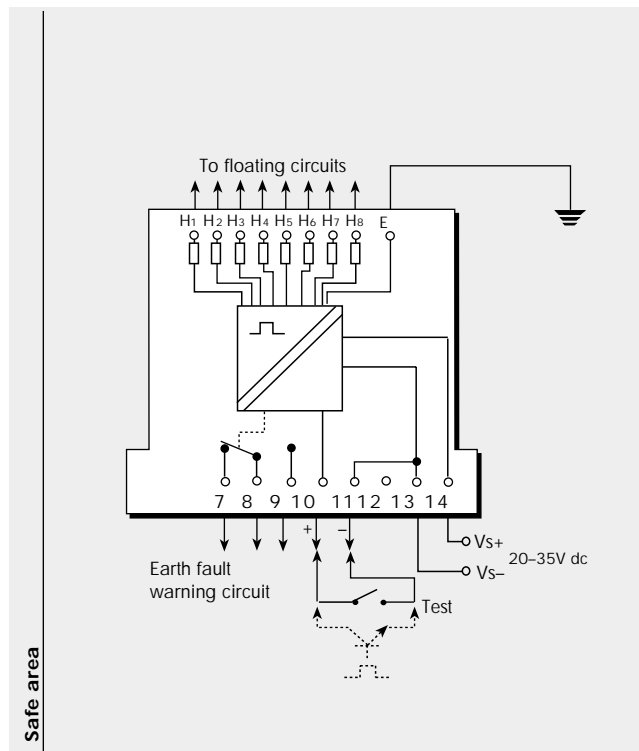

Terminal	Function
H ₁ - H ₈	Connections to MTL4000 Series modules
E	Earth
7	Earth fault signal (normally closed)
8	Earth fault signal (common)
9	Earth fault signal (normally open)
10	Test +ve
11	Test -ve
13	Supply -ve
14	Supply +ve

Power requirement, V_s

35mA max at 20 to 35V

18mA typical at 20 to 35V

Power dissipation within unit

0.9W max. at 24V

1.3W max. at 35V

0.45W typical at 24V

Isolation

250V ac between safe- and hazardous-area circuits

Safety description

9V, 65kΩ, 0.14mA, U_m=250Vrms or dc

Note: Three 3-way connectors are supplied with this unit as standard.

Please note that in addition to typical switch/proximity detector applications, the MTL4220 can also be used with switched outputs (eg, solenoids, alarms and LEDs), and with most analogue signals. For more information, call your local MTL representative.

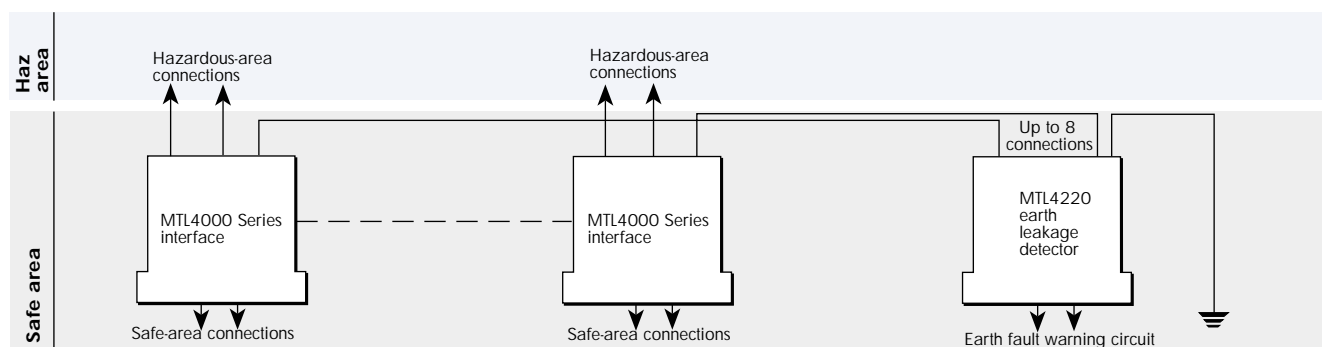

Note: some MTL4000 Series modules are multichannel and could require one connection for each channel.



EUROPE (EMEA) Tel: +44 (0)1582 723633 Fax: +44 (0)1582 422283
 AMERICAS Tel: +1 603 926 0090 Fax: +1 603 926 1899
 ASIA PACIFIC Tel: +65 487 7887 Fax: +65 487 7997
 E-mail: enquiry@mtl-inst.com Web site: www.mtl-inst.com

MTL4401 DE TRIP AMPLIFIER

SSI 3000



The MTL4401 SSI 3000 operates in a similar manner to that of conventional analogue trip amplifiers by monitoring a critical variable and providing controlled failure handling in case of failures in the primary monitoring control system. The SSI 3000 monitors the digital signal across a safe-area load and switches a relay if the digitally represented value crosses a threshold set by the user.

SPECIFICATION

See also common specification

Number of channels

One

Input signal

1–5V DE data

Input impedance >1MΩ

(Honeywell standard SW-927020-1010)

Power supply failure protection

Relay de-energises if supply fails

Response time

100ms

Relay contacts

Single-pole change-over

Response time: 10ms

Contact rating: 3VA, 30V, 100mA

Contact life expectancy: 10⁵ operations at maximum load.

Note: reactive loads must be adequately suppressed.

Switch functions

Test: Sets output to trip status

HI/LO: Selects high or low alarm action

Rotary number switches (3 off):

Set alarm level 00.0 to 99.9%

LED indicators

Green: 'POWER' Power on

Amber: 'RELAY' Relay status

Red: 'FAULT' Fault

Power requirements, Vs

35mA max at 20 to 35V dc

Power dissipation within unit

0.54W at 20V

1.10W at 35V

Long term drift

No recalibration necessary

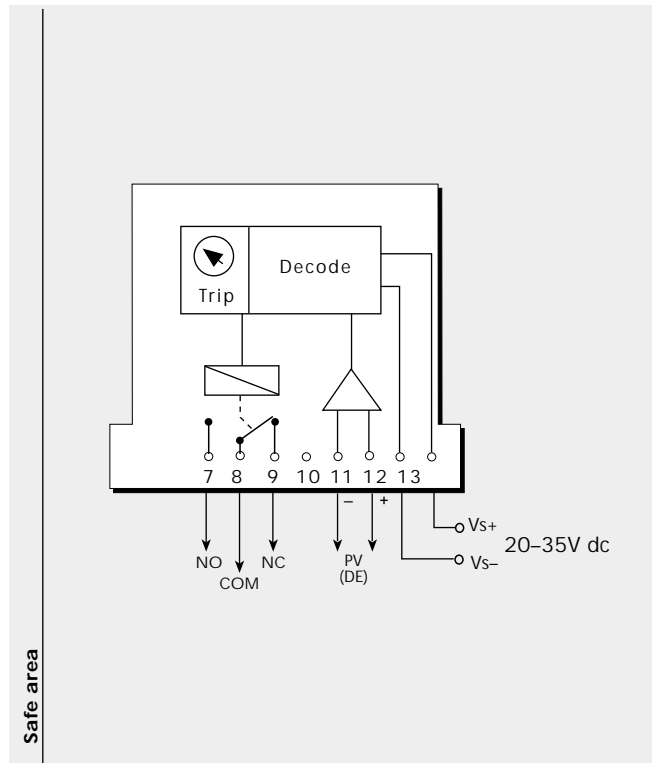

Terminal	Function
7	Relay (normally open)
8	Relay (common)
9	Relay (normally closed)
11	Input - (DE)
12	Input + (DE)
13	Supply -ve
14	Supply +ve

Switch functions

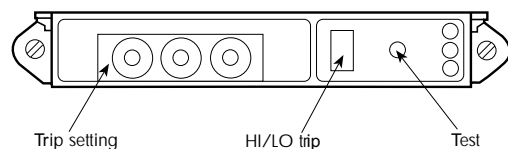

EUROPE (EMEA)
AMERICAS
ASIA PACIFIC
E-mail: enquiry@mtl-inst.com

Tel: +44 (0)1582 723633
Tel: +1 603 926 0090
Tel: +65 487 7887
Web site: www.mtl-inst.com

Fax: +44 (0)1582 422283
Fax: +1 603 926 1899
Fax: +65 487 7997

MTL4403 HIGH-LEVEL TRIP AMPLIFIER



This single-channel non-IS unit derives its input from the safe-area output of the MTL4041B or MTL4073 and compares the loop current with a trip level in the range 4 to 20mA. Two trip points are provided and may be set by multiturn potentiometers accessible on the top of the unit. Each trip can be set to indicate a high or low alarm. Test points are provided so that the approximate trip value (1 to 5V) may be measured using a portable voltmeter. A normally-open relay contact and amber LEDs indicate the trip condition.

SPECIFICATION

See also common specification

Number of channels

One

Location of signal source

Safe area only. Interface to hazardous area via suitable barrier/isolator.

Input range

4 to 20mA into 25Ω

Common-mode input voltage: 8V max

Hysteresis: 1% nominal of input range

Trip-point adjustment

Within 0.1% of input range over whole range

Supply voltage effect on trip point

<0.1% for supply voltage change 20 to 35V dc

Temperature effect on trip point

<0.02% of input range per °C

Response time

20ms nominal

Alarm functions

High alarm: relay energised when input less than trip point

Low alarm: relay energised when input greater than trip point

Power supply failure protection

Relay de-energises if supply fails

Alarm relay contacts

Single pole, normally open

Contact rating

3A at 35V dc (on standard MTL backplanes)

Note that reactive loads must be adequately suppressed.

LED indicators

Amber: one provided for each relay, ON when relay energised (not tripped)

Green: one provided for power indication

Power requirements

37mA at 24V dc

40mA at 20V dc

30mA at 35V dc

Power dissipation within unit

0.8W at 24V

0.9W at 35V

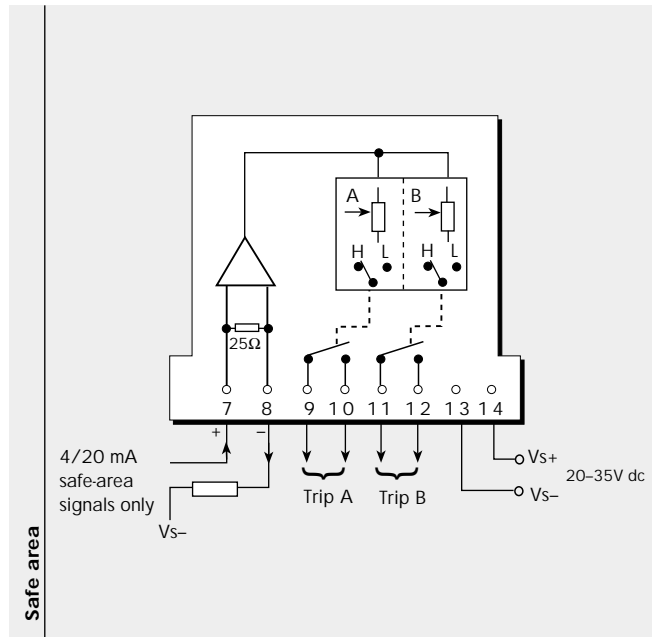

Terminal	Function
7	Input +ve
8	Input -ve
9	Output trip A (normally open)
10	Output trip A (common)
11	Output trip B (normally open)
12	Output trip B (common)
13	Supply -ve
14	Supply +ve



MTL4421RS GENERAL PURPOSE SWITCH OPERATED RELAY

with 24V logic override facility



The MTL4421RS enables an on/off device in a non-hazardous area to be controlled by a voltage signal from the control unit. It can drive loads such as solenoids, alarms, LEDs and other devices. Provided that 24V dc is applied to the override input, the solenoid/alarm can be operated by the control input. However, if the 24V dc signal is removed, the solenoid/alarm is turned off.

SPECIFICATION

See also common specification

Number of channels

One

Location of the load

Safe-area

Control input

Suitable for open collector or switch input logic drive or with external pull up.

0 = <4V applied across terminals 10 & 11

1 = >15V applied across terminals 10 & 11

Override input

A 24V logic signal must be applied across terminal 8 and 9 to allow the solenoid/alarm to be operated by the control input. If it is disconnected, the solenoid/alarm is off.

Control and override inputs

Control input state	Override input	Output relay
0	0V	open
1	0V	open
0	24V	closed
1	24V	open

Relay output characteristic

Normally open contacts

Contact rating: 60W, 125VA

Contact life expectancy: 0.5A, 15W /2A, 60W

1.8 x 10⁷ / 10⁶ operations at maximum load

Response time

set-/release-/ reset time

3ms/ 5ms/ 2ms

LED indicators

Green: one provided for power indication

Amber: one provided for status, ON when relay is closed

one provided for status, ON when output circuit is active

Power requirements

28mA at 24V dc

24mA at 20V dc

37mA at 35V dc

Power dissipation within unit

0.7W typical

Mounting

This module must not be placed next to intrinsic safety modules. Mounting on an alternative backplane is recommended. If mounted on the same backplane, 3 module positions must be left blank between IS and non-IS circuits. IS and non-IS wiring must be routed to maintain 50mm segregation.

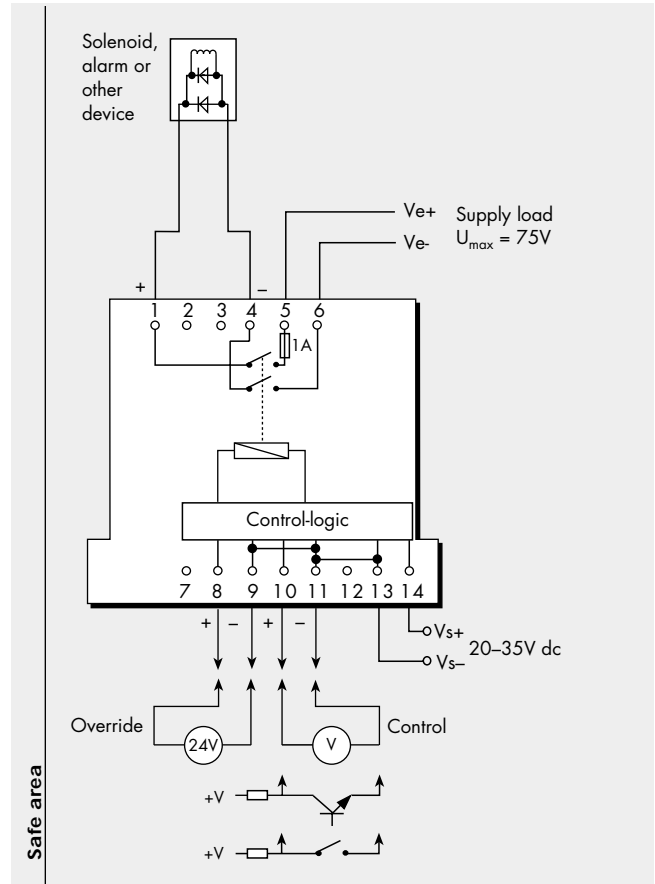

Terminal	Function
1	Output +ve
4	Output -ve
5	Supply load +ve (Fused 1A)
6	Supply load -ve
8	Override +ve
9	Override -ve
10	Control +ve
11	Control -ve
13	Supply -ve
14	Supply +ve



EUROPE (EMEA)
AMERICAS
ASIA PACIFIC
E-mail: enquiry@mtl-inst.com

Tel: +44 (0)1582 723633
Tel: +1 603 926 0090
Tel: +65 487 7887
Web site: www.mtl-inst.com

Fax: +44 (0)1582 422283
Fax: +1 603 926 1899
Fax: +65 487 7997

MTL4099 DUMMY ISOLATOR

The primary function of the MTL4099, which can be used with all other MTL4000 Series units, is to provide termination and earthing facilities for unused cable cores from hazardous areas.

SPECIFICATION

See also common specification

Weight
60g

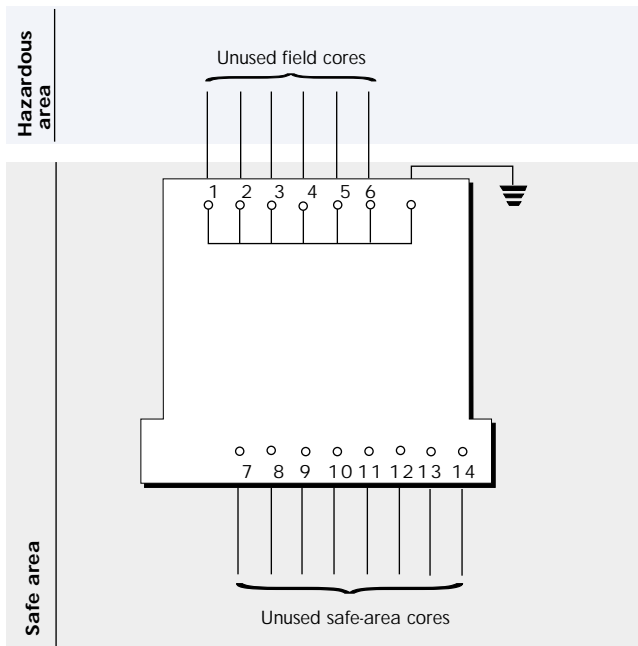

MTL4099N GENERAL PURPOSE FEED THROUGH MODULE

The feed-through termination module allows non-IS connections to the MTL4000 backplanes. The wires from the field are connected using screw terminals. Six terminals are provided for each contact of the multiway connector on the backplane. The terminals and cables conform to IS regulations so that non-IS and IS signals can be mixed on the same backplane.

Note: Must not be used with signals >50V or >0.25A

SPECIFICATION

Weight
30g

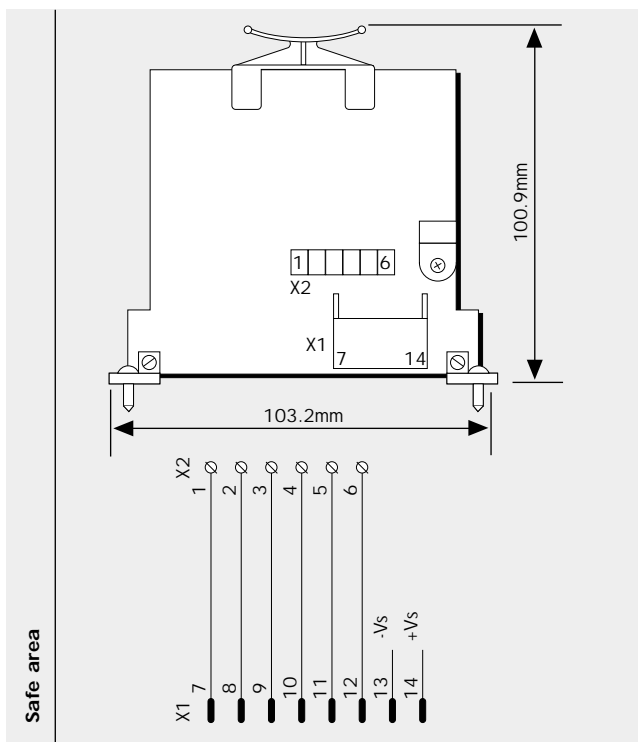

MTL4000 SERIES COMMON SPECIFICATION

DIMENSIONS (mm)

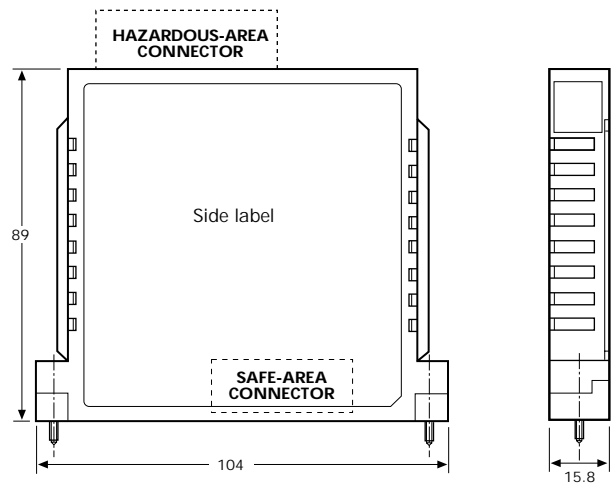
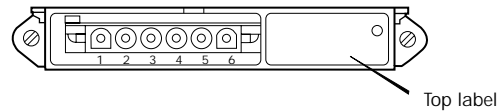

Location of units

Safe area

Isolation

250V rms between safe-area and hazardous-area terminals tested at 1500V rms min between safe and hazardous terminals

Long term drift

No recalibration necessary

Maximum safe-area voltage

$U_m = 250V$ rms or dc

Hazardous-area connectors

SCC01: Screw-clamp connector accommodates conductors of 14AWG max.

CCH01: Crimp-contact header accommodates: CRC01 crimps for conductors of 14–20AWG, or CRC02 crimps for conductors of 18–24AWG

Ambient temperature limits

–20 to +60°C (–4 to 140°F) continuous working

–40 to +80°C (–40 to 176°F) storage

Humidity

5 to 95% RH

Mounting

On MTL or user-supplied backplanes which in turn can be surface, DIN-rail or 19-inch rack mounted

Weight

100g approximately

CONDITIONS OF USE

The conditions governing the use of MTL4000 Series interface units are given in the relevant certificates and schedules, copies of which are available from MTL.

TO ORDER

See MTL4000 series ordering information



MAXIMUM CABLE PARAMETERS

Module	Group	BASEEFA				FM		
		μF	mH	or	$\mu\text{H}/\Omega$	Group	μF	mH
MTL4013/ 4014/4015/ 4016/4017	IIC	2.41	175		983	A+B	2.4	165
	IIB	16.8	680		1333	C	7.2	495
	IIA	75.0	1000		1333	D	19.2	1320
MTL4021/ 4021S/4024/ 4024R	IIC	0.104	1.82		52	A+B	0.17	3
	IIB	0.800	5.46		201	C	0.51	9
	IIA	2.780	14.5		423	D	1.36	24
MTL4023	IIC	0.11	1.45		40			
	IIB	0.84	7.22		158			
	IIA	2.97	14.42		326			
MTL4025	IIC	0.104	3.05		62			
	IIB	0.800	9.15		2.31			
	IIA	2.780	24.4		487			
MTL4031	IIC	0.094	4.21		58			
	IIB	0.73	17.37		219			
	IIA	2.42	35.29		463			
MTL4032	terminal 2 to 1							
	IIC	2.1	14.8		983	A+B	2.4	165
	IIB	16.80	53.4		1333	C	7.2	495
	IIA	75.00	112.7		1333	D	19.2	1320
	terminal 4 to 3 and 1							
	IIC	0.083	1.63		55	A+B	0.13	4.2
	IIB	0.650	7.72		210	C	0.39	12.6
	IIA	2.150	15.39		444	D	1.04	33.6
	terminal 5 to 4 and 1							
IIC	0.083	3.05		55	A+B	0.13	4.2	
IIB	0.650	9.15		210	C	0.39	12.6	
IIA	2.150	24.4		444	D	1.04	33.6	
MTL4041A	IIC	6.2	6.2		1674			
	IIB	55	22.5		6695			
	IIA	1000	50		13395			
MTL4041B	terminal 2 and 3 to 4 and 5							
	IIC	0.083	3.05		56	A+B	0.13	4.2
	IIB	0.650	9.15		210	C	0.39	12.6
	IIA	2.150	24.4		444	D	1.04	33.6
	terminal 6 to 4 and 5							
	IIC	100	13.06		2436			
IIB	1000	49.77		8931				
IIA	1000	105.05		18140				
MTL4041T	IIC	0.165	1.38		40			
	IIB	1.14	4.13		164			
	IIA	4.2	11.01		336			
MTL4041P	terminals 2 and 3 to 4 and 5							
	IIC	0.083	1.082		44	A+B	0.4	1.41
	IIB	0.650	5.46		170	C	0.43	5.75
	IIA	2.150	14.5		359	D	1.14	10.8
	terminals 6 to 4 and 5							
	IIC	100	13.06		2436			
IIB	1000	49.77		8931				
IIA	1000	105.05		18140				
MTL4042	IIB	0.65	4.79		117			
	IIA	2.15	9.61		239			
MTL4043	terminals 2, 4 and 5							
	IIC	0.083	3.05		56	A+B	0.13	4.2
	IIB	0.650	9.15		210	C	0.39	12.6
	IIA	2.150	24.4		444	D	1.04	33.6
	terminals 2, 5 and 6							
	A+B	0.13			1.94			
C	0.39			7.83				
D	1.04			14.9				
MTL4045B/C	IIC	0.083	3.05		55	A+B	0.13	4.2
	IIB	0.650	9.15		210	C	0.39	12.6
	IIA	2.150	24.4		444	D	1.04	33.6
MTL4044/4044D/ 4046/C	IIC	0.083	4.30		56			
	IIB	0.650	17.72		210			
	IIA	2.150	36.02		444			



MAXIMUM CABLE PARAMETERS (contd.)

Module	Group	BASEEFA				Group	FM	
		μF	mH	or	$\mu\text{H}/\Omega$		μF	mH
MTL4046S	IIC	0.17	3.72		67			
	IIB	1.14	15.51		252			
	IIA	4.2	31.35		531			
MTL4046P	IIC	0.083	1.82		44			
	IIB	0.650	5.46		168			
	IIA	2.150	14.5		354			
MTL4048	terminals 2 and 3 to 4 and 5							
	IIC	0.083	3.05		55	A+B	0.13	4.2
	IIB	0.650	9.15		210	C	0.39	12.6
	IIA	2.150	24.4		444	D	1.04	33.6
MTL4061	terminals 1 and 2 to 3 and terminals 4 and 5 to 6							
	IIC	0.083	3.05		55	A+B	0.13	4.2
	IIB	0.650	9.15		210	C	0.39	12.6
	IIA	2.150	24.4		444	D	1.04	33.6
MTL4081/4083	Consult MTL							
MTL4215/4216	Cable parameters defined by the circuit that is being switched							
MTL4220	For parameters when using other modules with MTL4220, refer to MTL							

Module	Grp	BASEEFA						Grp	FM							
		μF		mH		or			$\mu\text{H}/\Omega$		Con 1 terms 1&2		Con 1 terms 5&6		Con 2	
		Con 1	Con 2	Con 1	Con 2	Con 1	Con 2		μF	mH	μF	mH	μF	mH		
MTL4073	IIC	0.188	13.5	6.42	153	288	1295	A+B	11.0	500	1000	3.6	0.6	47		
	IIB	1.270	240	25.67	591	1057	2028	C	33.0	1500	1000	10.8	1.8	141		
	IIA	4.780	1000	53.02	1000	2228	2028	D	88.0	4000	1000	27.8	4.8	376		

Module	TÜV		
	Grp	μF	mH
MTL4113x/MTL4114x	IIC	6.2	45
	IIB	55	50



Region (Authority) Mines	Australia (NSW M)	Australia (SA)	Canada (CSA)	China (NEPSI)	CIS (VNIIVE)	Czech Republic (FTZU)	Hungary (BKI)	Japan (TIIS)	Korea (KISCO)	Poland (KDB)	UK (BASEEFA to CENELEC-standards)	UK (BASEEFA) Systems (to CENELEC-standards)	USA (FM)
Standard	CMRA67:1982	AS2380.1/7	C22.2 No.157	GB3836-1/-7	EN 50020 GOST22782.5-78	CSN33 0380	MSZEN 50014 MSZEN 50020	New Gijyutukijyun		PN-83/E-8110 PN-84/E-8107	EN 50014(1977) EN 50020(1977)	EN 50039 BS 5501: Pt9 1982	3610 Entily
Approved for	Coal mines	Ex (Ia) IIC	Class I, II, III Div.1 Gps A-G	Ex (Ia) IIC T6	Ex ia IIC	Ex ia IIC	[EEx ia] IIC EEx ib IIC/IIb	Ex ia IIC	Ex ia IIC	EEx ia IIC	[EEx ia] IIC	EEx ia IIC T4 or T6*	Class I, II, III Div. 1, 2, Grps A-G IS circuits Units can also be sited in Class I, II, III, Div 2 in appropriate enclosures
Model no.	Certificate/file no.												
	* T6 for switches or if the hazardous-area device is suitably certified												
MTL4013	MDA Ex ia 10084	Ex 1438X	LR36637-63	GYJ00106	D.00C.218	99Ex0770	Ex-97.C.300			95.087W	BAS01ATEX7162	Ex92C2323	J.I. 5W3A4.AX
MTL4014			LR36637-131								BAS01ATEX7164	Ex993C2387	
MTL4015		Ex 1438X	LR36637-49			99Ex0771			97-2548-Q1		BAS01ATEX7163	Ex91C2451	
MTL4016	MDA Ex ia 10084	Ex 1438X	LR36637-49	GYJ00106	D.00C.218	99Ex0771	Ex-97.C.300		97-2548-Q1	95.086W	BAS01ATEX7163	Ex91C2451	J.I. 0W2A6.AX
MTL4017			LR36637-87		D.00C.218					95.085W	BAS01ATEX7164	Ex993C2387	J.I. 4Y5A6.AX
MTL4021	MDA Ex ia 10084	Ex 1438X	LR36637-49	GYJ00106	D.00C.221	99Ex0772	Ex-97.C.300		97-2549-Q1	95.084W	BAS01ATEX7165	Ex92C2002	J.I. 0W2A6.AX
MTL4021S		Ex 1438X				99Ex0772					BAS01ATEX7165	Ex92C2002	J.I. 5Y7A1.AX
MTL4023			LR36637-87							95.083W	BAS01ATEX7166	Ex93C2500	J.I. 4Y5A6.AX
MTL4024			LR36637-131			99Ex0772			97-2549-Q1		BAS01ATEX7165	Ex92C2002	J.I. 5Y7A1.AX
MTL4024R											BAS01ATEX7165		
MTL4025			LR36637-49			99Ex0772				95.084W	BAS01ATEX7165	Ex92C2002	J.I. 0Z6A6.AX
MTL4031											BAS01ATEX7167	Ex94C2266	
MTL4032			LR36637-87		172	99Ex0834					BAS01ATEX7168	Ex94C2175	J.I. 4Y5A7.AX
MTL4041A			1065362								BAS99ATEX7028	Ex99E2029	
MTL4041B	MDA Ex ia 10118	Ex 1438X	LR36637-68	GYJ00106	D.00C.442	99Ex0773	Ex-97.C.300	C13408		95.082W	BAS01ATEX7169	Ex92C2004	J.I. 1X6A4.AX
MTL4041P			LR36637-68							95.082W	BAS01ATEX7169	Ex92C2004	J.I. 4X5A3.AX
MTL4041T											BAS00ATEX7149		
MTL4042											BAS01ATEX7170		J.I. 5Y7A1.AX
MTL4043											BAS01ATEX7171		J.I. 4D0A8.AX
MTL4044			1065362	GYJ00106	D.00C.442						BAS99ATEX7061		
MTL4044D											BAS99ATEX7061		
MTL4045B		Ex 1438X	LR36637-87		D.00C.220†	98Ex0023	Ex-97.C.300		97-2550-Q1	95.080W†	BAS01ATEX7172	Ex93C2479	J.I. 0D7A0.AX
MTL4045C			LR36637-87			98Ex0023			97-2550-Q1		BAS01ATEX7172	Ex93C2479	J.I. 0D7A0.AX
MTL4046			1065362								BAS98ATEX7293	Ex98E2294	
MTL4046C			1065362								BAS98ATEX7293	Ex98E2294	
MTL4046P		Ex 2320X	LR36637-87			97Ex0070				96.472W	BAS01ATEX7173	Ex94C2194	J.I. 4Y5A6.AX
MTL4046S											BAS99ATEX7293	Ex98E2294	
MTL4048						99Ex0774					BAS01ATEX7175	Ex94C2069	
MTL4061							Ex-97.C.300				BAS01ATEX7176	Ex94C2041	
MTL4073		Ex 1438X	LR36637-72	GYJ00106	D.00C.222	99Ex0775	Ex-97.C.300		97-2551-Q1	95.078W	BAS01ATEX7177	Ex93C2174	J.I. 2X8A5.AX
MTL4081		Ex 2342X									BAS01ATEX7178		
MTL4083		Ex 3549X	LR36637-87								BAS01ATEX7179	Ex97D2140	J.I.6D1A8.AX
MTL4113P											Baseefa03ATEX0297		
MTL4114P											Baseefa03ATEX0297		
MTL4215										95.079W	BAS01ATEX7180		J.I. 4Y5A7.AX
MTL4216											BAS01ATEX7180		J.I. 5Y7A1.AX
MTL4220											BAS01ATEX7181	Ex95C2291	



EUROPE (EMEA)
AMERICAS
ASIA PACIFIC
E-mail: enquiry@mtl-inst.com

Tel: +44 (0)1582 723633
Tel: +1 603 926 0090
Tel: +65 487 7887

Fax: +44 (0)1582 422283
Fax: +1 603 926 1899
Fax: +65 487 7997

Web site: www.mtl-inst.com

MTL4000 SERIES BACKPLANES, ACCESSORIES AND ENCLOSURES

- ◆ Standard 4-, 8-, 16- and 24-way backplanes with screw-clamp or multiway safe-area connectors
- ◆ Backplane mounting accessories for installation on DIN-rail, flat surfaces or in 19-inch racks
- ◆ Customised backplanes option – designed and produced without the need for IS certification
- ◆ Standard enclosures for 8-, 16-, or 2 x 16-way backplanes; rated IP65
- ◆ Hazardous-area plug-in screw-clamp or crimp connectors

***Customised backplanes
See 'System integration'
for more details***



The **MTL4000 Series backplanes**, enclosures and other accessories provide comprehensive, flexible and remarkably compact mounting facilities for system vendors, original equipment manufacturers and end users alike.

Standard MTL backplanes are available to accommodate 4, 8, 16, or 24 modules with either screw-clamp or multiway connectors for the safe-area circuits. On an individual backplane, any module can be plugged into any position and module types can be mixed.

For 8-, 16- and 24-way backplanes, primary and secondary 24V dc power supplies are provided by screw-clamp connectors which plug into the backplanes. Power to several 8- or 16-way backplanes can be interconnected to reduce and simplify wiring – see instruction manual INM4000 for details.

Optional accessories include colour coded tagging strip kits for all three sizes of backplane and earth rail kits for 8 and 16-way versions. Mounting accessories are available for surface (all backplanes), T-section and G-section DIN-rail (8- and 16-way versions), and a horizontal plate for mounting 24-way backplanes in 19-inch racks.

Weatherproof enclosures are available for applications where separate safe-area enclosures are required for backplanes with modules. Available in three sizes to accommodate one 8-way, one 16-way or two 16-way backplanes, they are manufactured from GRP giving protection against dust and water to IEC529:IP65. The lids are made from transparent high-strength polycarbonate so that LEDs, switches, etc, on the tops of the modules are easy to see. Distribution of both safe- and hazardous-area cabling is taken care of by internal trunking.

Other accessories include screw-clamp and crimp hazardous-area connectors and crimps and crimp tools for the latter.

MTL4000 Series system integration

MTL provides a complete design and/or manufacturing service for system integration. This covers design considerations (including advice and engineering drawings for users who intend to produce their own backplanes) right through to manufacture. This service give vendors and users of process control and safety systems the opportunity to integrate MTL4000 (and MTL4840) Series modules directly into their system architectures. Since there are no hazardous-area circuits on the backplanes, customised versions can be designed and produced without the need for IS certification, so simplifying design, reducing lead times and lowering costs.



MTL BPM/BPS BACKPLANES SPECIFICATION AND DIMENSIONS

SPECIFICATION

Power requirements, Vs

21V dc to 35V dc through plug-in connectors

Safe-area connections

BPM: Elco 8016 56-pin male connectors – one connector for each group of 8 modules

BPS: 2.5mm² screw-clamp terminals – 6 positions per module

Power sense

BPM: Through Elco 8016 connectors

BPS: Through separate plug-in crimp connector

Weight (without modules or accessories)

BPS04:	96g
BPM08:	159g
BPS08:	225g
BPM16:	286g
BPS16:	419g
BPM24:	382g
BPS24:	592g

BACKPLANES – FEATURES

Model No.	No. of modules	Safe-area connections	Mounting			Accessories	
			Surface	DIN-rail (T or G)	19-inch rack	Earth-rail kit	Tagging strip kit
BPM08	8	Multiway	Yes	Yes	No	Yes	Yes
BPM16	16	Multiway	Yes	Yes	No	Yes	Yes
BPM24	24	Multiway	Yes	No	Yes	No	Yes
BPS04	4	Screw-clamp	Yes	Yes	No	No	No
BPS08	8	Screw-clamp	Yes	Yes	No	Yes	Yes
BPS16	16	Screw-clamp	Yes	Yes	No	Yes	Yes
BPS24	24	Screw-clamp	Yes	No	Yes	No	Yes

DIMENSIONS (mm)

BPS04 4-way backplane (screw-clamp connectors)

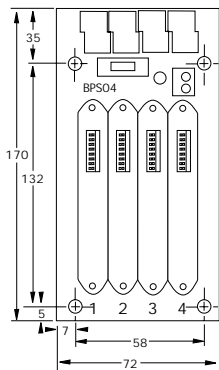

BPM08 8-way backplane (multiway connectors)

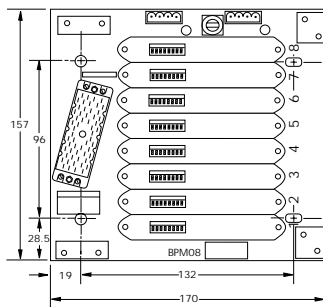

BPS08 8-way backplane (screw-clamp connectors)

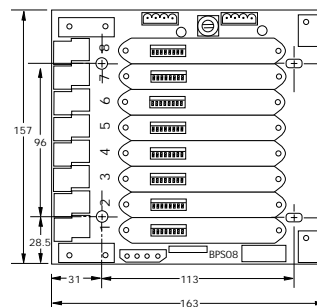

BPM16 16-way backplane (screw-clamp connectors)

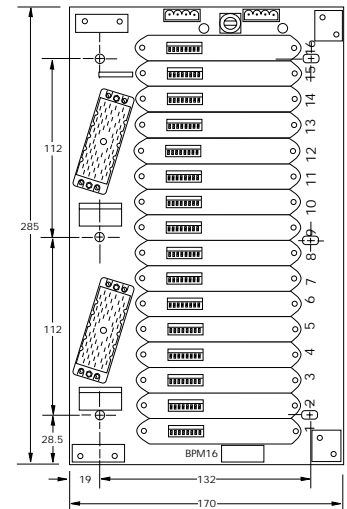

BPM24 24-way backplane (multiway connectors)

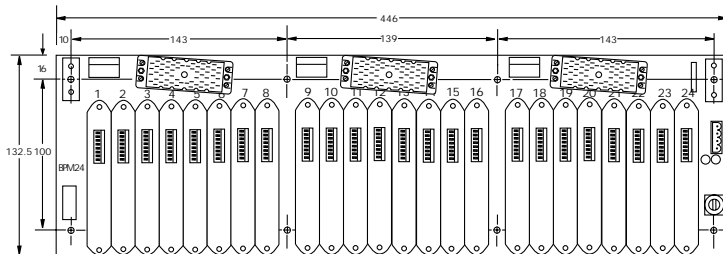

BPS16 16-way backplane (screw-clamp connectors)

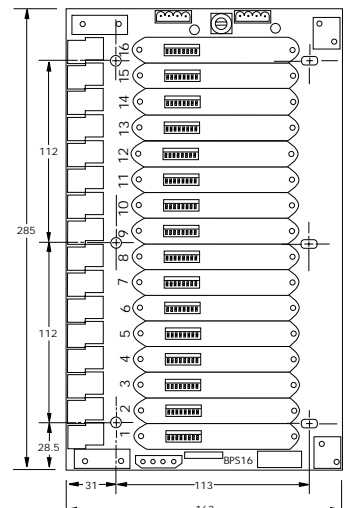

BPS24 24-way backplane (screw-clamp connectors)

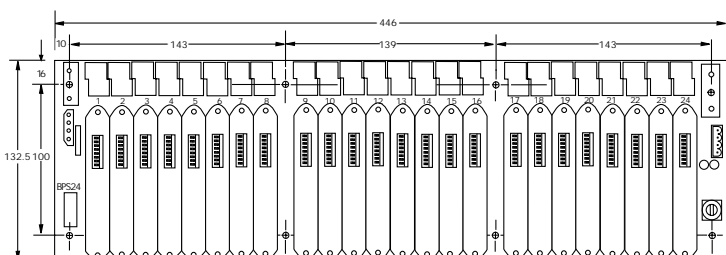

MTL4000 SERIES ACCESSORIES

MTL4000 MODULE ACCESSORIES

- CCH01** Hazardous-area crimp connector
SCC01 Hazardous-area screw-clamp connector
SCJ01 Hazardous-area screw-clamp connector with integral CJC sensor



- CRC01** Crimps 0.5-2.0mm² (20-14 AWG), pack of 100

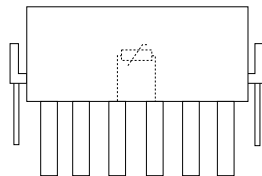

- CRC02** Crimps 0.2-0.8mm² (24-18 AWG), pack of 100
CRT01 Crimp tool for 1.5-6.0mm² (15-9 AWG) wire
CRT02 Crimp tool for 0.1-1.6mm² (27-15 AWG) wire
CRR01 Crimp removal tool for CRC01, CRC02 or power sense crimps

MTL4000 BACKPLANE ACCESSORIES

- ERK08** Earth rail kit for BPM/BPS08 backplanes
ERK16 Earth rail kit for BPM/BPS16 backplanes
TSK08 Tagging strip kit for BPM/BPS08 backplanes
TSK16 Tagging strip kit for BPM/BPS16 backplanes
TSK24 Tagging strip kit for BPM/BPS24 backplanes
SMS01 Backplane surface mounting kit, pack of 40
DMK01 Backplane DIN-rail mounting kit, G- or T-section, pack of 40

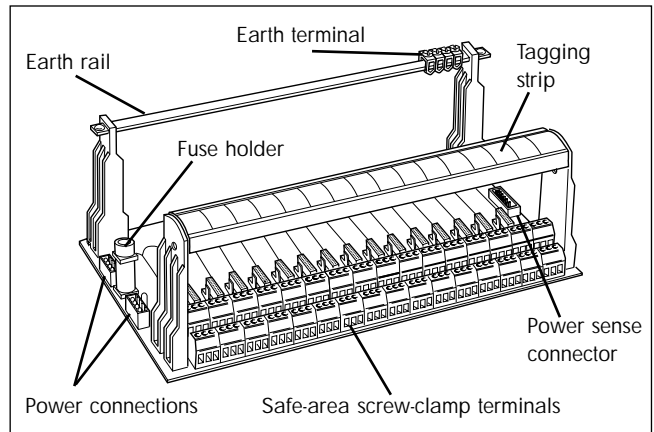

- BMK08** Mounting kit – surface/DIN-rail accessories for one 4- or 8-way backplane
BMK16 Mounting kit – surface/DIN-rail accessories for one 16-way backplane
HMP24 Horizontal mounting plate and screws for 19-inch rack, 24-way backplane only,
ELC56 Elco 8016, 56-way cable plug kit
FUS08 Fuse kit, BPM/BPS08 backplanes, pack of 10
FUS16 Fuse kit, BPM/BPS16 backplanes, pack of 10
FUS24 Fuse kit, BPM/BPS24 backplanes, pack of 10
MPL01 Module position labels (blank), pack of 50

HMP24 Horizontal mounting plate for 19-inch rack, 24-way backplane only, (includes mounting screws)

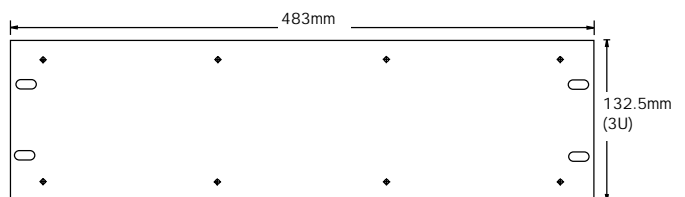

Maximum height from backplane to top of tagging strip: 92mm

MTL BX08 ENCLOSURE

SPECIFICATIONS

- BX08:** for 1 x BPM08 or BPS08 backplane
Location
 Safe area
Protection
 Dust-tight and water-jet proof to IEC529:IP65
Ambient temperature limits
 -20 to +60°C, depending upon modules fitted
 (see instruction manual INM4000 for details)

Construction

- Base: GRP (glass-fibre reinforced polyester)
 Lid: transparent high-strength polycarbonate

Finish

- Base: light grey
 Lid: transparent

Lid fixing

- Captive fixing screws

Gland fixing

- Side mounted gland plate, detachable for drilling by user

Mounting

- By exterior surface-fixing lugs (zinc-passivated steel)

Internal cable trunking

- Provided on all enclosures

Backplane mounts

- Necessary surface mounting kits (of screws, washers, spacers and retaining washers) are provided with the enclosure

Weight (without backplanes and units)

- BX08: 3.7kg



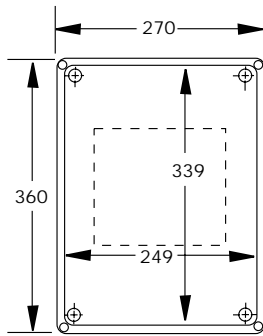

BX08

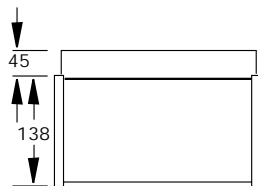

MTL4000 SERIES ORDERING INFORMATION



Intrinsically safe interface units

Specify module number

Module accessories

CCH01	Hazardous-area crimp connector
CRC01	Large crimps (100 per pack)
CRC02	Small crimps (100 per pack)
SCC01	Screw clamp connector
SCJ01	Hazardous-area screw clamp connector with integral CJC sensor (required for use with MTL4073 with THC inputs requiring CJC)
MPL01	Module position label (blank) (50 per pack)

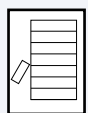

Backplanes

BPM08	8-way backplane multiway connector
BPM16	16-way backplane multiway connector
BPM24	24-way backplane multiway connector
BPS04	4-way backplane screw-clamp connector
BPS08	8-way backplane screw-clamp connector
BPS16	16-way backplane screw-clamp connector
BPS24	24-way backplane screw-clamp connector

Backplane mounting accessories

DMK01	DIN-rail mounting kit, T- or G-section (pack of 40) 8-way backplanes require 4 16-way backplanes require 6
SMS01	Surface mounting kit (pack of 40) 4 and 8-way backplanes require 4 16-way backplanes require 6 24-way backplanes require 8
HMP24	Horizontal mounting plate and screws for 19-inch rack mounting 24-way backplanes only
BMK08	Mounting kit for one 4- or 8-way backplane
BMK16	Mounting kit for one 16-way backplane

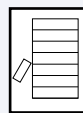

Backplane accessories

ERK08	Earth rail kit for 8-way backplanes BPM08 or BPS08
ERK16	Earth rail kit for 16-way backplanes BPM16 or BPS16
TSK08	Tagging strip kit for 8-way backplanes BPM08 or BPS08
TSK16	Tagging strip kit for 16-way backplanes BPM16 or BPS16
TSK24	Tagging strip kit for 24-way backplanes BPM24 or BPS24
ELC56	Elco 8016, 56-way cable plug kit for use with BPM style backplanes 1 required per 8 modules
FUS08	Fuse kit for 4 and 8-way backplanes (10 per pack)
FUS16	Fuse kit for 16-way backplane (10 per pack)
FUS24	Fuse kit for 24-way backplanes (10 per pack)

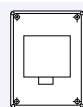

Enclosures

BX08	8-way enclosure suitable for 1 BPM08 or BPS08
------	--



General Accessories

CRT01	Crimp tool
CRT02	Crimp tool
CRR01	Crimp removal tool for CRC01, CRC02, and power sense crimps



Literature

INM4000	MTL4000 Series instruction manual
AN9013	MTL4000 Series application note

