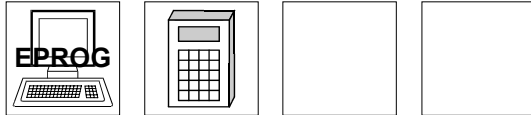

Linear-Encoder LA-66-K SSI

- **Pressure proof model, direct installation into hydraulic cylinder is possible**
- **Sensing of linear motion**
- **Non contact and no wear sensing**
- **Programmable, scaleable**
- **SSI (Synchronous-Serial Interface)**

7**Electrical Data**

Measuring Principle	Magnetostrictive
Standard Measuring length (mm).....	150, 300, 500, 700, 750, 1000, 1500, 2000, 2500, 3000 > 3000 upon request
Sensor Capacity.....	max. 20 bit
* Resolution.....	max. 0,01 mm
Operating Voltage	19-27 V DC
Power Dissipation (No Load)	< 5 W
Programming via RS485.....	PC IBM compatible (EPROG), Programming-Terminal PT-100N
* Output Code (programmable).....	Binary, Gray, BCD
Clock Input	Opto-coupler
Clock Rate.....	95 kHz - 1 MHz
Cycle Time	See Dimension Drawing
Data Transmission Length	Dependent on Cable Section, Shield, Clock Rate etc.
Data Output.....	RS422 (2-wire)
Inputs	
* F/R	Count Direction
* Preset	Electronic Adjustment
Logic Levels	"0" < + 2 V DC, "1" > + 8 V DC, max. 30 V DC
Pin Configuration.....	Upon Request

* Programmable Parameter

Environmental Data

Electromagnetic compatibility (EMC).....	EN 61000-4-2 (IEC-801-2) / EN 61000-4-4 (IEC-801-4)
Operating Temperature.....	0°-70°C (32° to 158° F) (Optional -20° to +70°C) (-4° to 158° F)
Storage Temperature	-30° to +80°C (-22° to 178° F)
Relative Humidity	98 % (non condensing)
* Protection Class	IP 65 (DIN 40 050)
* Protection is determined by connector specified	

Mechanical Data

Linearity	< 0.05 % of Stroke Length
Reproducibility	≤ 0,01 mm
Hysteresis	< 0.1 mm
Temperature Coefficient	< 5 μm / °C
Vibration (Sinus 50-2000 Hz) according to DIN IEC 68-2-6	≤ 100 m/s ² (10g)
Shock (11ms) according to DIN IEC 68-2-27	≤ 1000 m/s ² (100g)
Pressure Resistance (Option)	600 bar static
Rod Material	Cr/Ni-alloy
Magnetic Interference (at rod circumference)	< 3 mT (milli Tesla)
Operating Speed and Mounting Orientation	No restrictions
Magnet Type (Standard).....	T4-M33
Magnet Type (Option).....	T3-U64
Rod Mounting	Option
Mechanical Special Types.....	upon request
Connection	12 pin connector

Dimensional Drawing

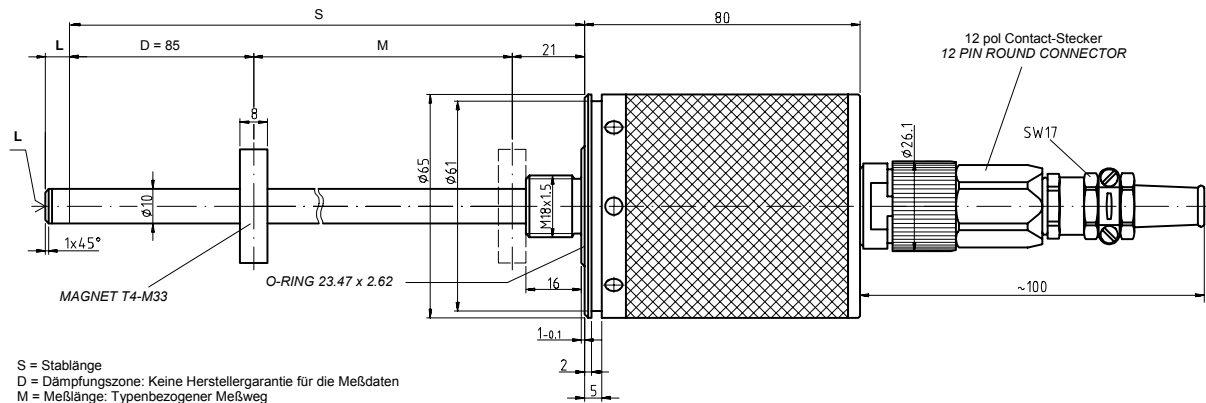

S = Stablänge
 D = Dämpfungszone: Keine Herstellergarantie für die Meßdaten
 M = Meßlänge: Typenbezogener Meßweg
 L = 5 mm Zusatzlänge mit M4x5 bei Option Stabspitzenlagerung

S = TOTAL LENGTH
 D = DAMPENING ZONE: IN THIS AREA NO MEASURING SIGNAL IS PRODUCED
 M = STROKE LENGTH
 L = 5 MM ADDITIONAL LENGTH WITH M4x5 FOR OPTION ROD MOUNTING

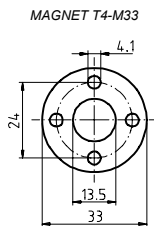

Meßlänge M (mm) STROKE LENGTH M (mm)	Stablänge S (mm) TOTAL LENGTH S (MM)	Zykluszeit (ms) CYCLE (ms)
150	256	1,4
300	406	1,4
500	606	1,4
700	806	1,4
750	856	1,4
1000	1106	1,8
1500	1606	2,7
2000	2106	3,6
2500	2606	4,5
3000	3106	5,4